



ARROW SIDE STEP

PART #: TB-T30

FITS: 2022-Up Toyota Tundra CrewMax



60-120 min



Cutting Not Required



Drilling Not Required

Torque & Tools

Fastener Size	Tightening Torque (ft-lbs)	Wrench Required		Allen Wrench Required	
			<input checked="" type="checkbox"/> 10mm		<input type="checkbox"/> 4mm
<input checked="" type="checkbox"/> 6mm	<input checked="" type="checkbox"/> 7-8.5		<input checked="" type="checkbox"/> 13mm		<input type="checkbox"/> 5mm
<input checked="" type="checkbox"/> 8mm	<input checked="" type="checkbox"/> 18-20		<input type="checkbox"/> 16mm		<input type="checkbox"/> 6mm
<input type="checkbox"/> 10mm	<input type="checkbox"/> 35-40		<input type="checkbox"/> 18mm		<input type="checkbox"/> 8mm
<input type="checkbox"/> 12mm	<input type="checkbox"/> 60-70				

BEFORE INSTALLATION

REMOVE CONTENTS FROM BOX. VERIFY ALL PARTS ARE PRESENT. READ INSTRUCTIONS CAREFULLY BEFORE STARTING INSTALLATION. ASSISTANCE IS RECOMMENDED.

Part List

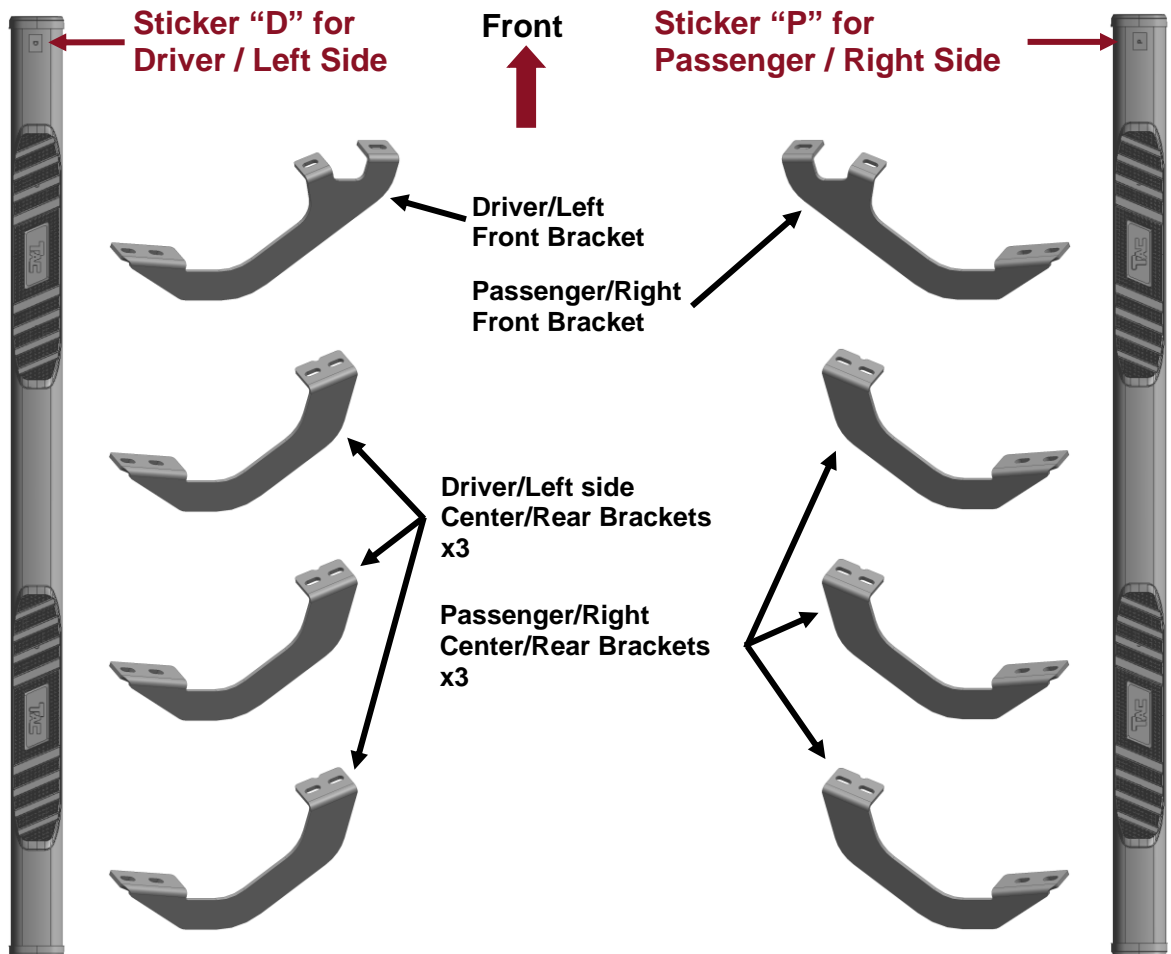

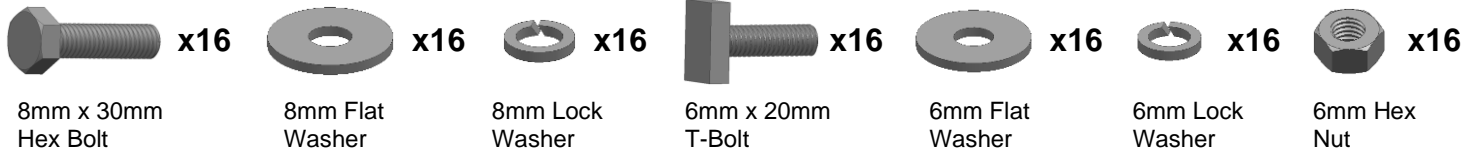

PLEASE NOTE THAT THE FOLLOWING PICTURES ARE BASED ON THE DRIVER SIDE INSTALLATION

STEP 1

Starting on the Driver/Left front of the vehicle, remove the plastic plugs or factory hex bolts covering the (2) threaded holes in the floor panel, (Fig 1).

FIG 1

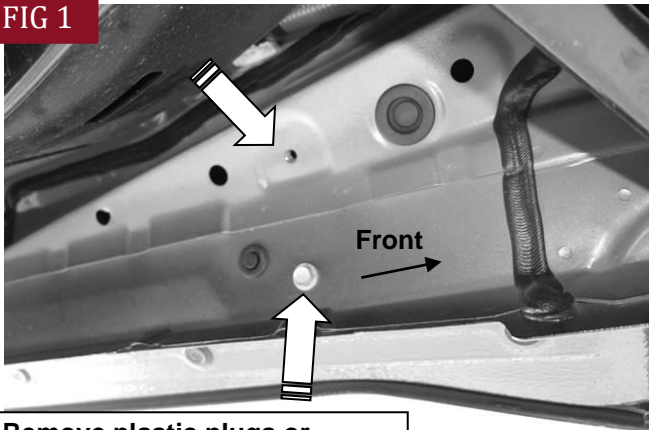

Remove plastic plugs or factory hex bolts (if equipped)

(Fig 1) Driver/Left side front mounting location.

STEP 2

Select Driver/Left Front Mounting Bracket. Attach the Bracket to the panel with (2) 8mm Hex Bolts, (2) 8mm Lock Washers and (2) 8mm Flat Washers, (Fig 2). Do not tighten hardware.

FIG 2

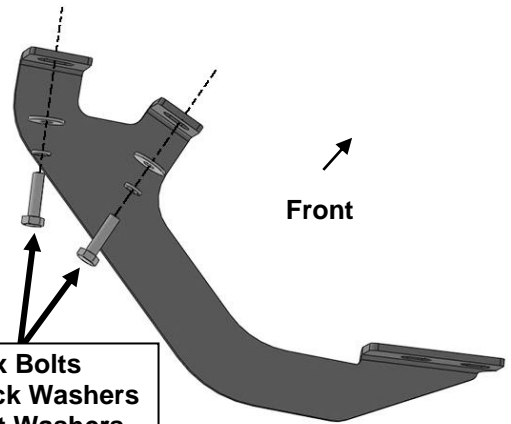

(2) 8mm Hex Bolts
(2) 8mm Lock Washers
(2) 8mm Flat Washers

(Fig 2) Attach Driver/left Front Bracket to the front mounting location

STEP 3

Next, move to the 2nd mounting location, (Fig 3). Select (1) Driver/Left Center/Rear Mounting Bracket. **IMPORTANT: The Center and Rear Brackets are the same.** Repeat Step 2 to install the center Mounting Bracket, (Fig 6).

FIG 3

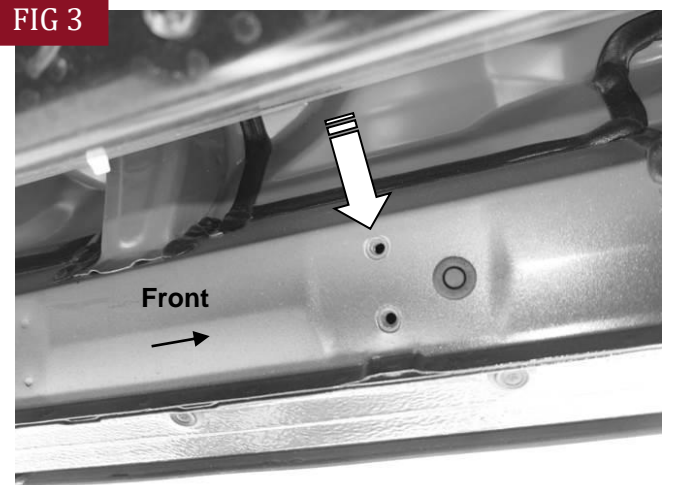

(Fig 3) Driver/left side second Bracket mounting location

STEP 4

Move along to the 3rd mounting location, **(Fig 4)**. Repeat **Step 2** to install Driver/Left Center/Rear Mounting Bracket on 3rd mounting location, **(Fig 6)**

FIG 4

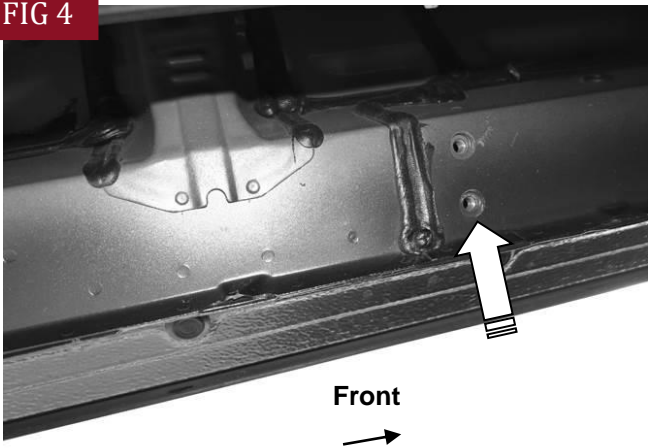

(Fig 4) Driver/left side third mounting location

STEP 5

Continue to the last, 4th, mounting location at the back of the cab, **(Fig 5)**. Repeat **Step 2** to install the Driver/Left Center/Rear Mounting Bracket on rear mounting location, **(Fig 6)**. When properly installed, the cradles on the Brackets will face toward the rear.

FIG 5

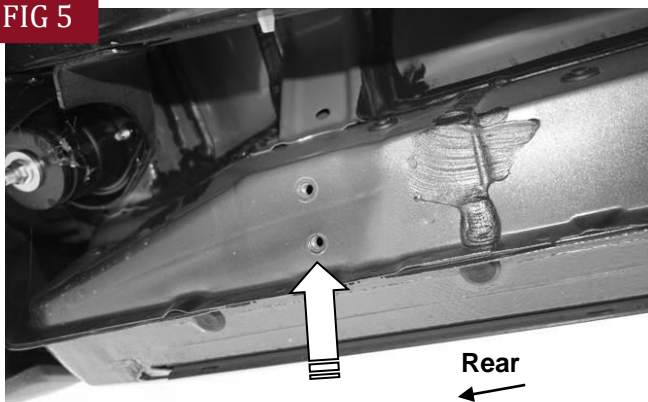

(Fig 5) Driver/left side fourth mounting location

FIG 6

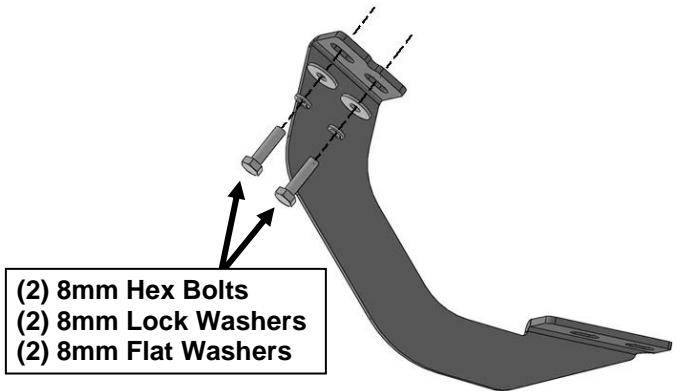

(Fig 6) Attach Driver/left Center/Rear Bracket to the mounting location

STEP 6

Once all (4) Brackets have been fully installed, carefully unwrap the Driver/left Side Step, **NOTE: The Driver/Left Side Step will have a Sticker "D" on the front.** Use (8) 6mm T-Bolts and insert into the slots underneath the Side Step, (4 T-Bolts per channel) **(Fig 7)**. **IMPORTANT: Do not slide the Side Step front to back or damage to the finish may result.**

FIG 7

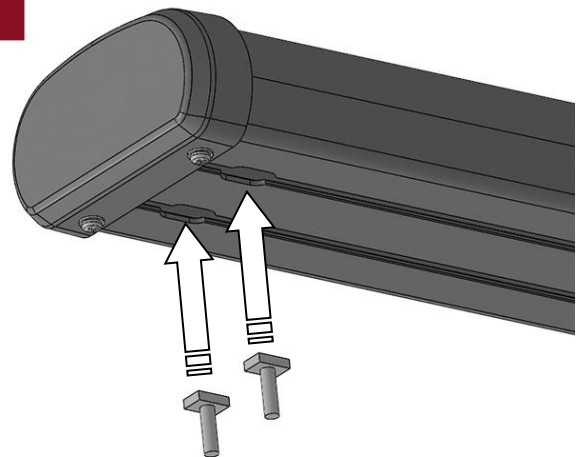

(Fig 7) Insert (8) 6mm T-Bolts into the slot underneath the Side Step (4 T-Bolts per channel)

STEP 7

Attach the Side Step onto the (4) Mounting Brackets with (8) 6mm Flat Washers, (8) 6mm Lock Washers, and (8) 6mm Hex Nuts (**Fig 8**). Do not tighten hardware.

FIG 8

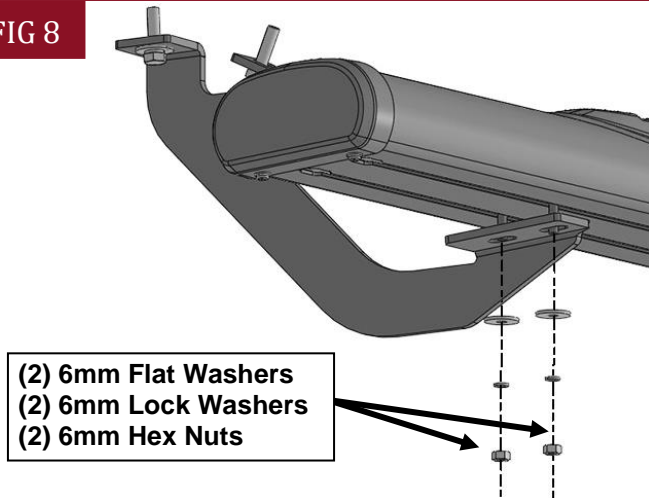

(Fig 8) Attach Side Step to the Mounting Brackets

STEP 8

Level and adjust the Driver/Left Side Step as desired and tighten all hardware.

STEP 9

Repeat **Steps 1-8** to attach the Passenger/Right Side Step.

STEP 10

Do periodic inspections to the installation to make sure that all hardware is secure and tight.

Attention

To protect your investment, do not use any type of polish or wax that may contain abrasives that could damage the finish.

Mild soap may be used also to clean the Side Steps.