



ARROW SIDE STEP

PART #: TB-T27

FITS: 2007-2021 Toyota Tundra Double Cab



60-120 min



Cutting Not Required



Drilling Not Required

Torque & Tools

Fastener Size	Tightening Torque (ft-lbs)	Wrench Required		Allen Wrench Required	
			<input checked="" type="checkbox"/> 10mm		<input type="checkbox"/> 4mm
<input checked="" type="checkbox"/> 6mm	<input checked="" type="checkbox"/> 7-8.5		<input checked="" type="checkbox"/> 13mm		<input type="checkbox"/> 5mm
<input checked="" type="checkbox"/> 8mm	<input checked="" type="checkbox"/> 18-20		<input type="checkbox"/> 16mm		<input type="checkbox"/> 6mm
<input type="checkbox"/> 10mm	<input type="checkbox"/> 35-40		<input type="checkbox"/> 18mm		<input type="checkbox"/> 8mm
<input type="checkbox"/> 12mm	<input type="checkbox"/> 60-70				

BEFORE INSTALLATION

REMOVE CONTENTS FROM BOX. VERIFY ALL PARTS ARE PRESENT. READ INSTRUCTIONS CAREFULLY BEFORE STARTING INSTALLATION. ASSISTANCE IS RECOMMENDED.

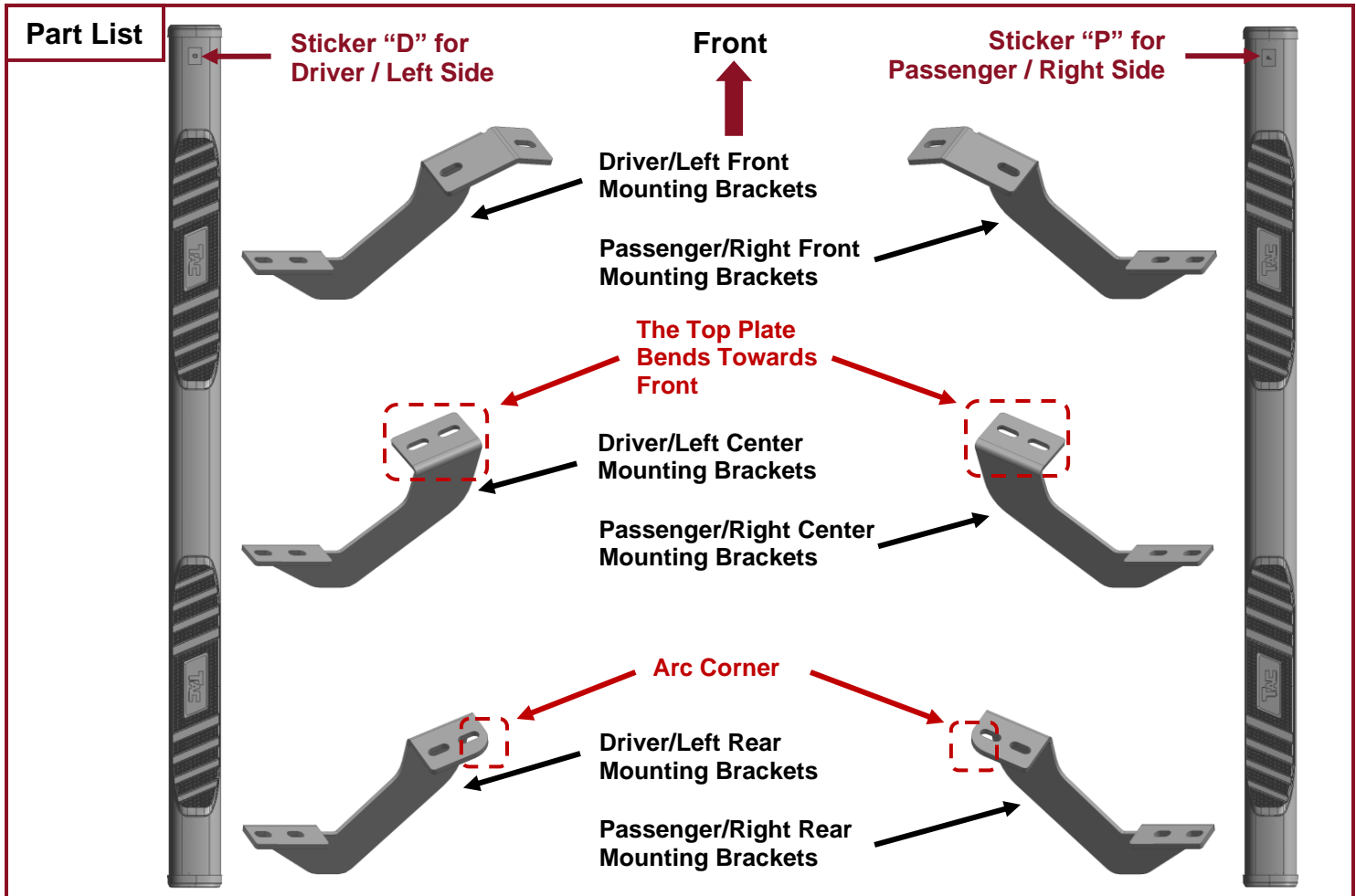

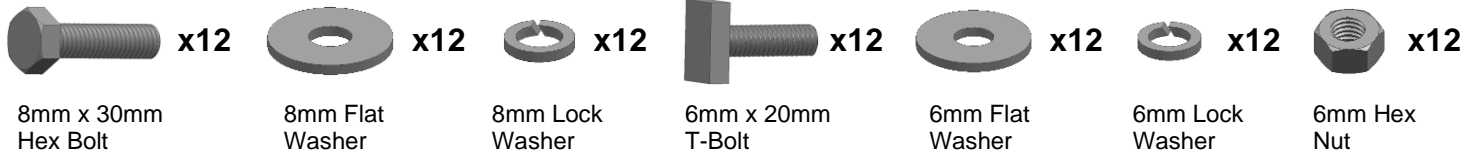

PLEASE NOTE THAT THE FOLLOWING PICTURES ARE BASED ON THE DRIVER SIDE INSTALLATION

STEP 1

Starting on the Driver/Left front of the vehicle, remove the plastic plugs or hex bolts covering the (2) threaded holes in the floor panel, **(Fig 1)**.

FIG 1

Remove plastic plugs or factory hex bolts (if equipped)

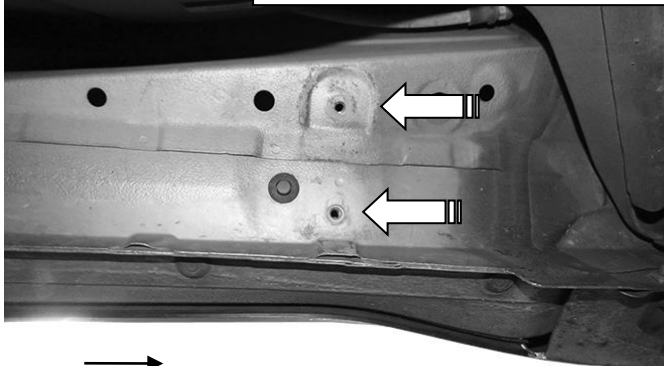

(Fig 1) Driver/Left Front mounting location

STEP 2

Select Driver/Left Front Mounting Bracket. Attach the Bracket to the panel with (2) 8mm Hex Bolts, (2) 8mm Lock Washers and (2) 8mm Flat Washers, **(Fig 2)**. Do not tighten hardware.

FIG 2

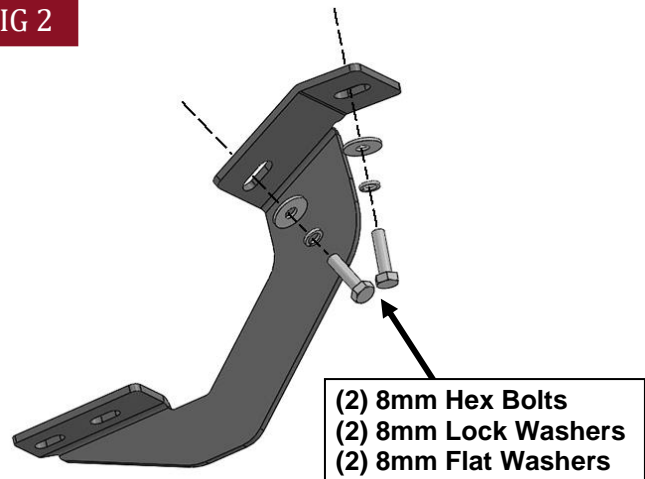

(Fig 2) Attach Driver/Left Front Mounting Bracket to the floor panel

STEP 3

Move along the body panel to the center mounting location, **(Fig 3)**. Select Driver/Left Center Mounting Bracket. **IMPORTANT: The Center and Rear Mounting Brackets look very similar but are unique. Please identify the Brackets according to the Part List.** Repeat **Step 2** to attach the Bracket to the floor panel, **(Fig 4)**. Do not tighten hardware.

FIG 3

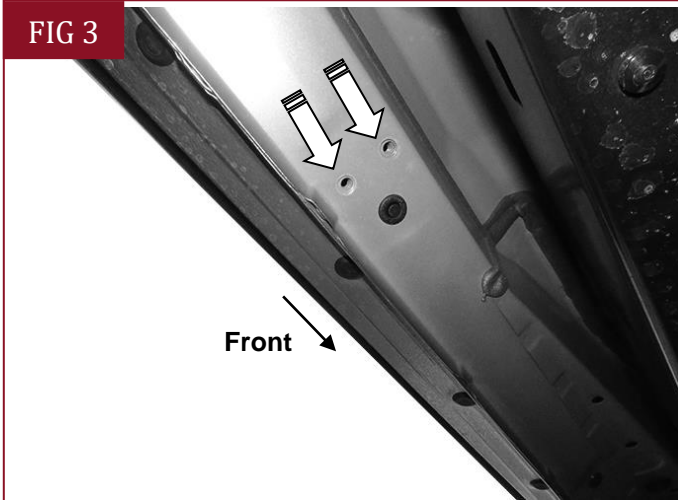

(Fig 3) Driver/Left Center mounting location

FIG 4

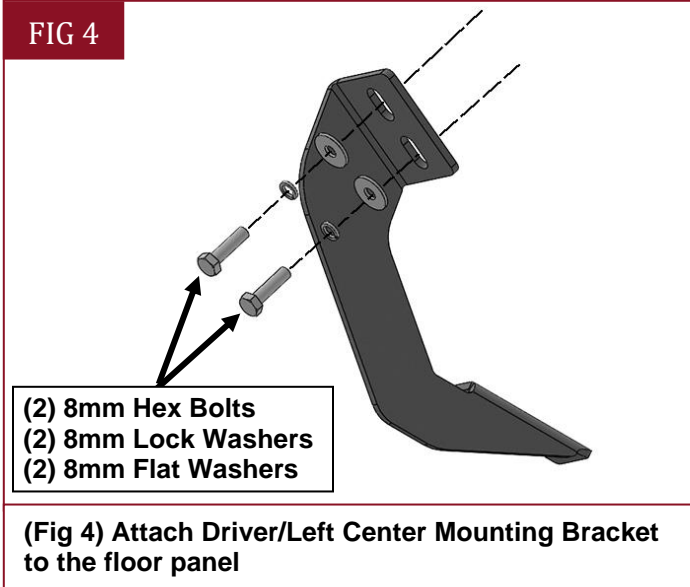

(Fig 4) Attach Driver/Left Center Mounting Bracket to the floor panel

STEP 4

Move along the body panel to the rear mounting location, **(Fig 5)**. Select Driver/Left Rear Mounting Bracket. **IMPORTANT: The Rear and Center Mounting Brackets look very similar but are unique. Please identify the Brackets according to the Part List.** Repeat **Step 3** to attach the Rear Mounting Bracket to the floor panel. Do not tighten hardware.

FIG 5

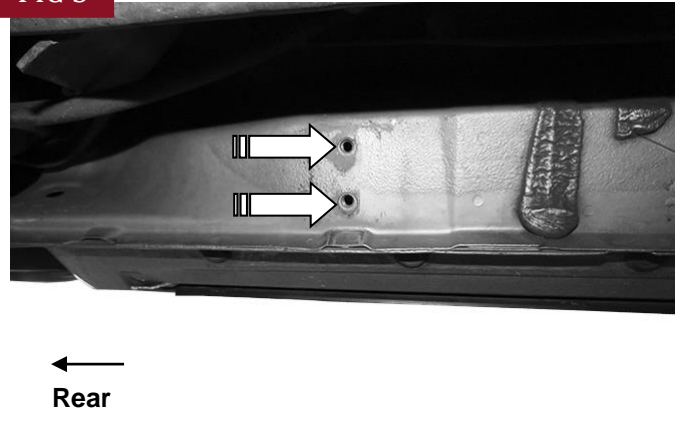

(Fig 5) Driver/Left Rear mounting location

STEP 5

Select the Driver/Left Side Step. **NOTE: The Driver/Left Side Step will have a Sticker "D" on the front.** Insert (6) 6mm T-Bolts into the channels in the bottom of the Side Step, (**Fig 6**), (3 T-Bolts per channel). Attach the Side Step to the (3) Mounting Brackets with (6) 6mm Flat Washers, (6) 6mm Lock Washers and (6) 6mm Hex Nuts, (**Fig 7**). Do not tighten hardware.

FIG 6

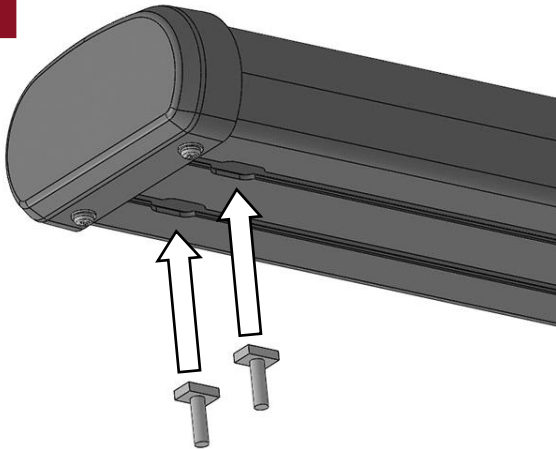

(Fig 6) Insert (6) 6mm T-Bolts into the channels in the bottom of the Side Step, (3 T-Bolts per channel)

FIG 7

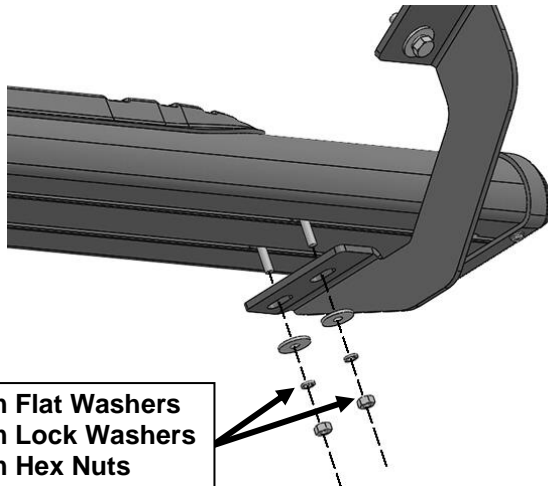

(Fig 7) Attach Driver/Left Side Step to the Mounting Brackets

STEP 6

Level and adjust the Side Step and fully tighten all hardware.

STEP 7

Repeat **Steps 1-6** to attach the Passenger/Right Side Step.

STEP 8

Do periodic inspections to the installation to make sure that all hardware is secure and tight.

Attention

To protect your investment, do not use any type of polish or wax that may contain abrasives that could damage the finish.

Mild soap may be used also to clean the Side Steps.