



ARROW SIDE STEP

PART #: TB-N24

FITS: 2005-Up Nissan Frontier Crew Cab



60-120 min



Cutting Not Required



Drilling Not Required

Torque & Tools

Fastener Size	Tightening Torque (ft-lbs)	Wrench Required		Allen Wrench Required	
			<input checked="" type="checkbox"/> 10mm		<input type="checkbox"/> 4mm
<input checked="" type="checkbox"/> 6mm	<input checked="" type="checkbox"/> 7-8.5		<input checked="" type="checkbox"/> 13mm		<input type="checkbox"/> 5mm
<input checked="" type="checkbox"/> 8mm	<input checked="" type="checkbox"/> 18-20		<input type="checkbox"/> 16mm		<input type="checkbox"/> 6mm
<input type="checkbox"/> 10mm	<input type="checkbox"/> 35-40		<input type="checkbox"/> 18mm		<input type="checkbox"/> 8mm
<input type="checkbox"/> 12mm	<input type="checkbox"/> 60-70+				

BEFORE INSTALLATION

REMOVE CONTENTS FROM BOX. VERIFY ALL PARTS ARE PRESENT. READ INSTRUCTIONS CAREFULLY BEFORE STARTING INSTALLATION. ASSISTANCE IS RECOMMENDED.

Part List



Sticker "D" for Driver / Left Side

Front



Sticker "P" for Passenger / Right Side

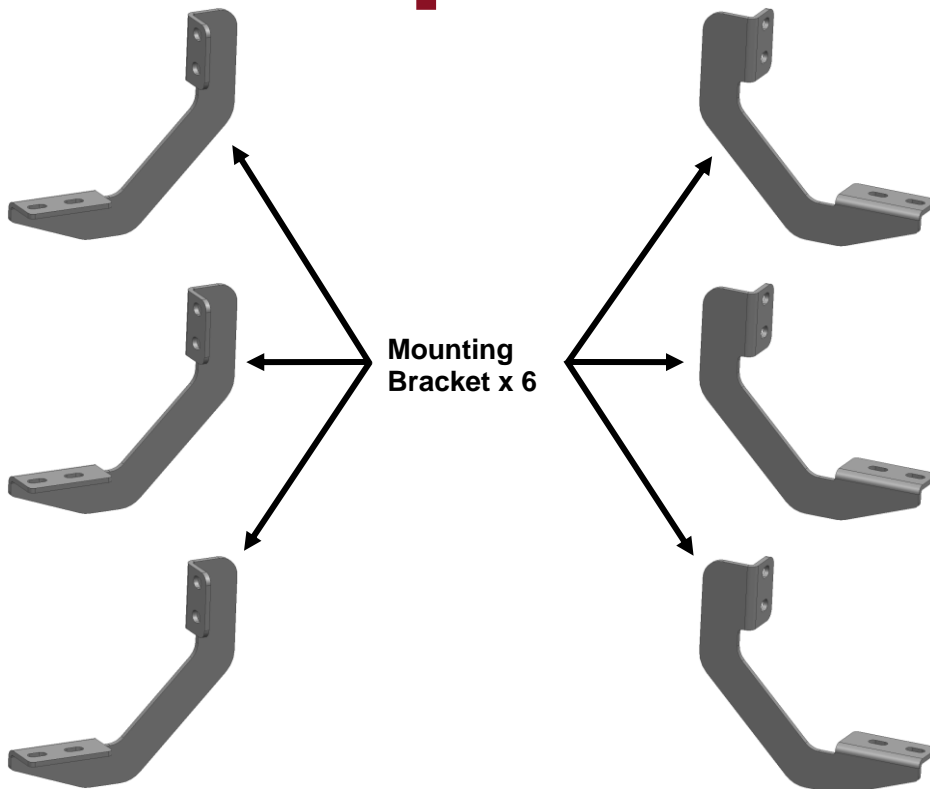

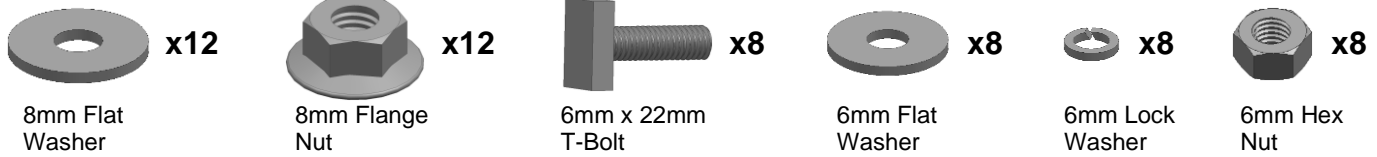

PLEASE NOTE THAT THE FOLLOWING PICTURES ARE BASED ON THE PASSENGER SIDE INSTALLATION

STEP 1

Starting from underneath the Passenger/Right body panel. Locate the front factory mounting location along the inner side of the body, **(Fig 1)**. Use a wire brush or thread chaser die to remove excess paint and/or undercoating from two studs.

FIG 1

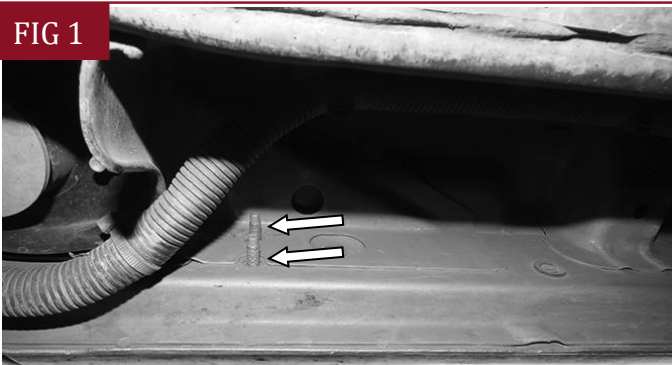

←
Front

(Fig 1) Passenger/Right front mounting location

STEP 2

Select the (1) Mounting Bracket. Attach the Bracket to the Passenger/Right front location with (2) 8mm Flat Washers and (2) 8mm Flange Nuts, **(Fig 2)**. Do not tighten hardware.

FIG 2

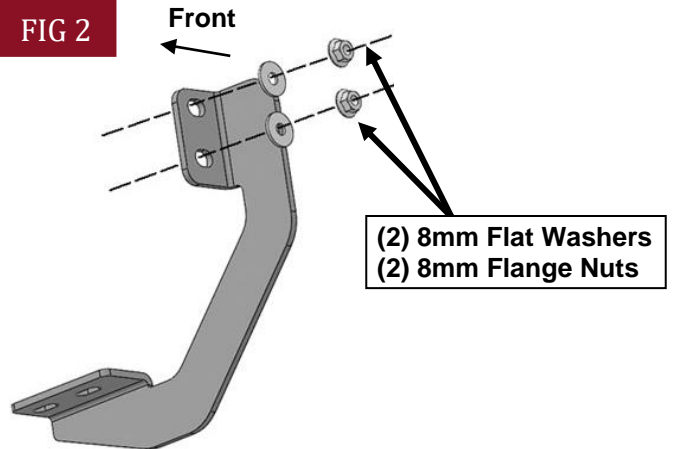

(Fig 2) Attach (1) Mounting Bracket to the Passenger/Right front location

STEP 3

Repeat **Steps 1-2** to attach (2) Mounting Brackets to the Passenger/Right center and rear locations, **(Figs 3-4)**. Do not tighten hardware.

FIG 3

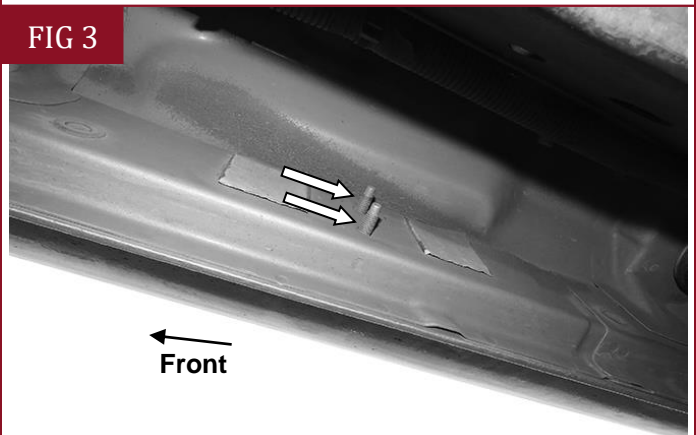

←
Front

(Fig 3) Passenger/Right center mounting location

FIG 4



(Fig 4) Passenger/Right rear mounting location

STEP 4

Select the Passenger/Right Side Step. Insert (6) 6mm T-Bolts into the slots underneath the Side Step (Fig 5). **NOTE: The Passenger/Right Side Step will have a Sticker "P" on the front.**

IMPORTANT: Do not slide the Side Step front to back or damage to the finish may result. Attach the Side Step to the (3) Mounting Brackets with (6) 6mm Flat Washers, (6) 6mm Lock Washers, and (6) 6mm Hex Nuts (Fig 6). Do not tighten hardware.

FIG 5

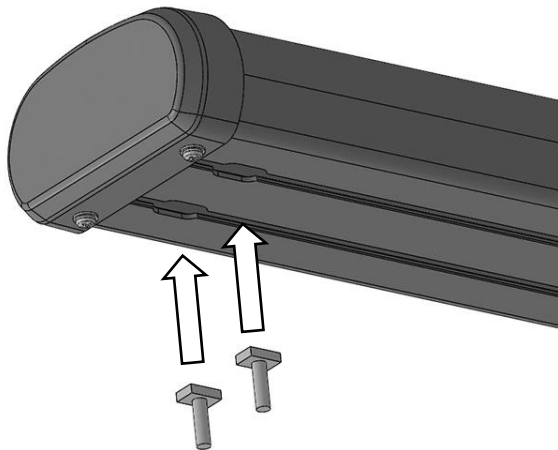

(Fig 5) Insert (6) 6mm T-Bolts into the channels in the bottom of the Side Step, (3 T-Bolts per channel)

FIG 6

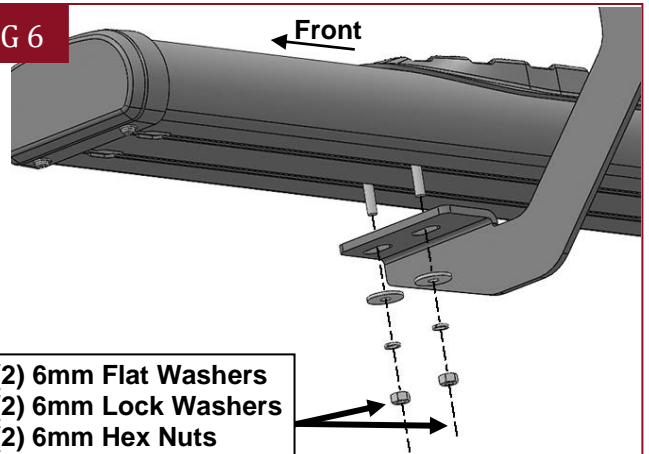

(Fig 6) Attach the Passenger/Right Side Step to the Mounting Brackets

STEP 5

Level and adjust the Side Step and fully tighten all hardware.

STEP 6

Repeat **Steps 1—5** to attach the Driver/Left Side Step.

STEP 7

Do periodic inspections to the installation to make sure that all hardware is secure and tight.

Attention

To protect your investment, do not use any type of polish or wax that may contain abrasives that could damage the finish.

Mild soap may be used also to clean the Side Steps.