



ARROW SIDE STEP

PART #: TB-J21

FITS: 2018-Up Jeep Wrangler JL 4 Door



60-120 min



Cutting Not Required



Drilling Not Required

Torque & Tools

Fastener Size	Tightening Torque (ft-lbs)	Wrench Required		Allen Wrench Required	
			10mm		<input type="checkbox"/> 4mm
<input checked="" type="checkbox"/> 6mm	<input checked="" type="checkbox"/> 7-8.5		13mm		<input type="checkbox"/> 5mm
<input checked="" type="checkbox"/> 8mm	<input checked="" type="checkbox"/> 18-20		16mm		<input type="checkbox"/> 6mm
<input checked="" type="checkbox"/> 10mm	<input checked="" type="checkbox"/> 35-40		18mm		<input type="checkbox"/> 8mm
<input type="checkbox"/> 12mm	<input type="checkbox"/> 60-70				

BEFORE INSTALLATION

REMOVE CONTENTS FROM BOX. VERIFY ALL PARTS ARE PRESENT. READ INSTRUCTIONS CAREFULLY BEFORE STARTING INSTALLATION. ASSISTANCE IS RECOMMENDED.

Part List

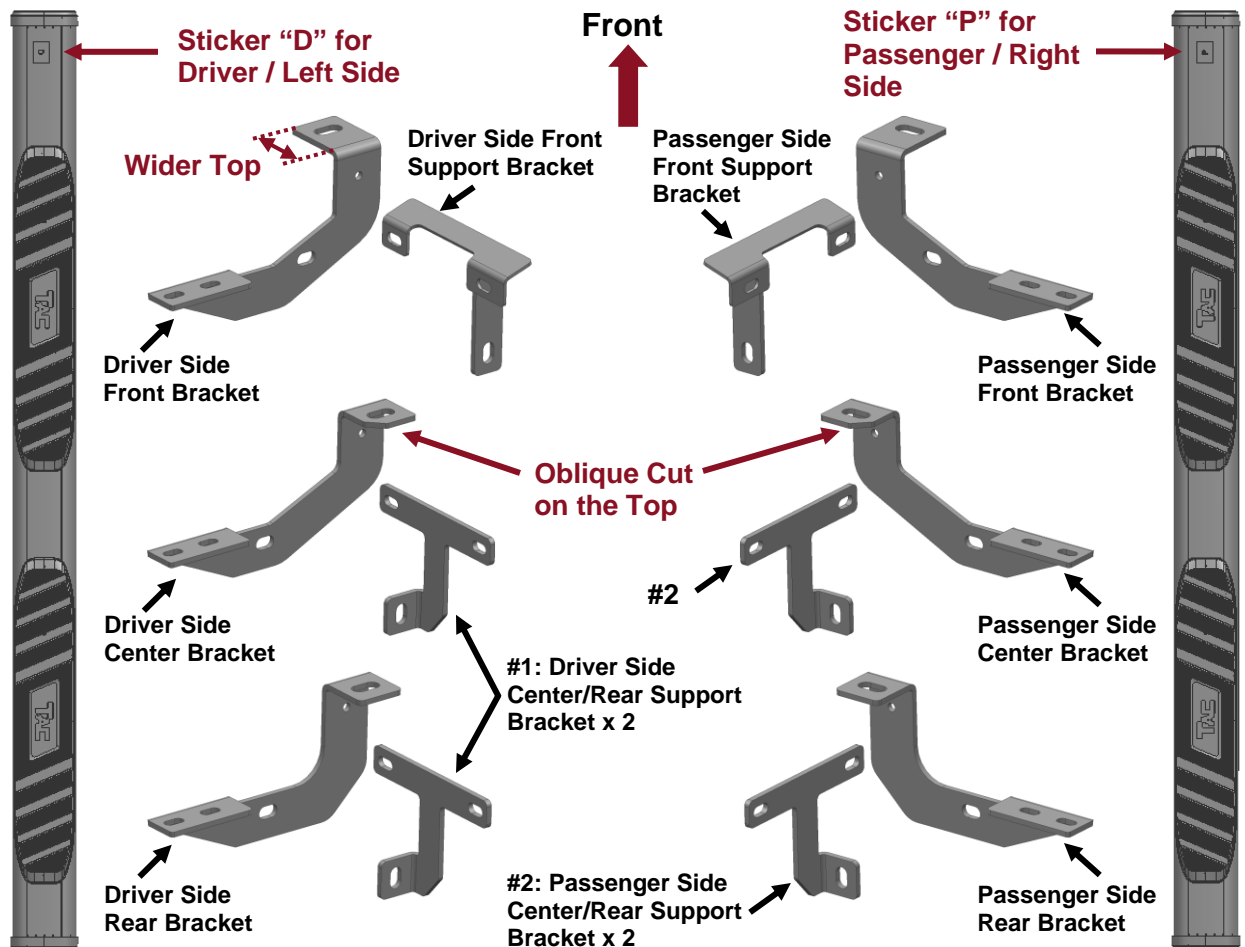

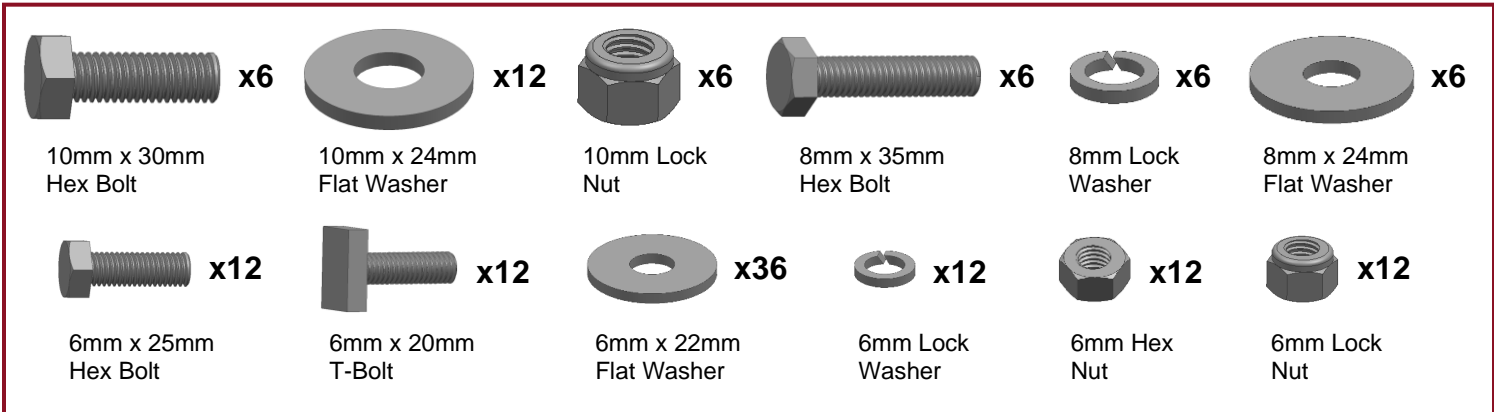

PLEASE NOTE THAT THE FOLLOWING PICTURES ARE BASED ON THE PASSENGER SIDE INSTALLATION

STEP 1

Start installation on the Passenger/Right front of the of the vehicle. Find the front threaded insert located in between the first pair of holes along the pinch weld, (Fig 1).

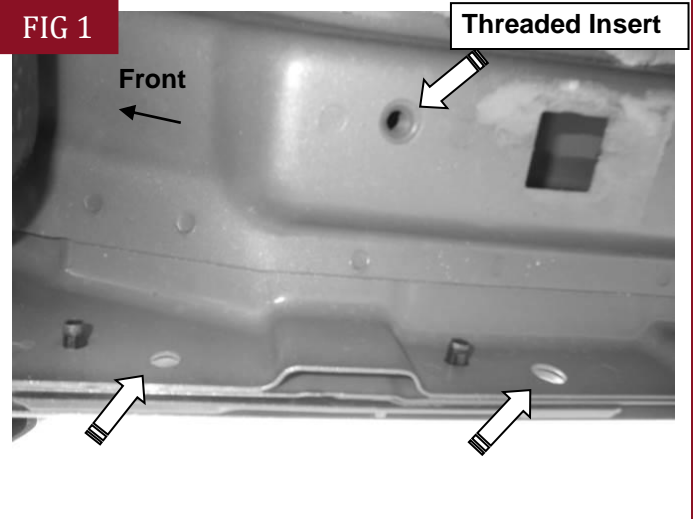

(Fig 1) Passenger/Right side front mounting location

STEP 2

Select the Passenger/Right Front Mounting Bracket. **IMPORTANT:** Please identify the Front, Center, Rear Brackets according to the illustration on Part List and Fig 2 Below. Attach the Mounting Bracket to the threaded insert using (1) 8mm Hex Bolt, (1) 8mm Lock Washer and (1) 8mm Flat Washer, (Fig 3). Do not tighten hardware.

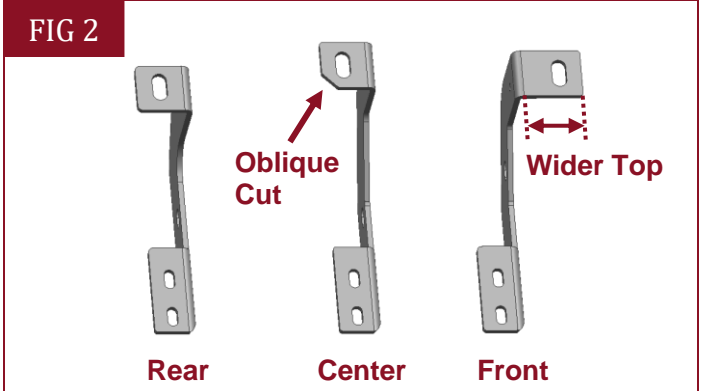

(Fig 2) The Mounting Brackets are similar but are unique (Passenger Side Show)

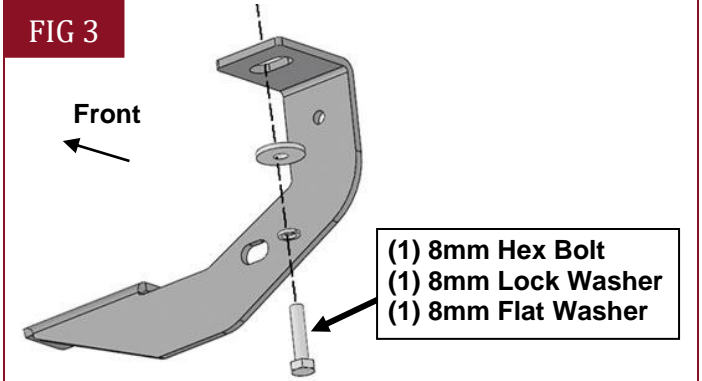

(Fig 3) Attach the Passenger/Right Front Mounting Bracket to the front location

STEP 3

Select the Passenger/Right Front Support Bracket. **IMPORTANT:** Please identify the Front, Center, Rear Support Brackets according to the illustration on Part List. Attach the Support Bracket to the pinch weld using (2) 6mm Hex Bolts, (4) 6mm Flat Washers and (2) 6mm Nylon Lock Nuts, (Fig 4). **NOTE:** Insert Bolts from the outside of the pinch weld. Attach the Support Bracket to the Mounting Bracket with (1) 10mm Hex Bolt, (2) 10mm Flat Washers and (1) 10mm Nylon Lock Nut, (Fig 5). Do not tighten hardware.

FIG 4

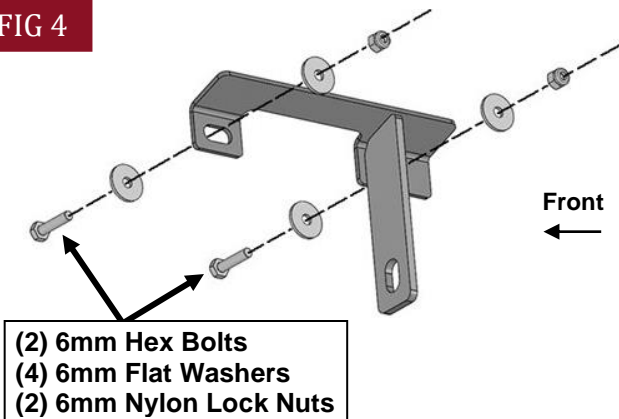

(Fig 4) Attach the Passenger/Right Front Support Bracket to the pinch trim

FIG 5

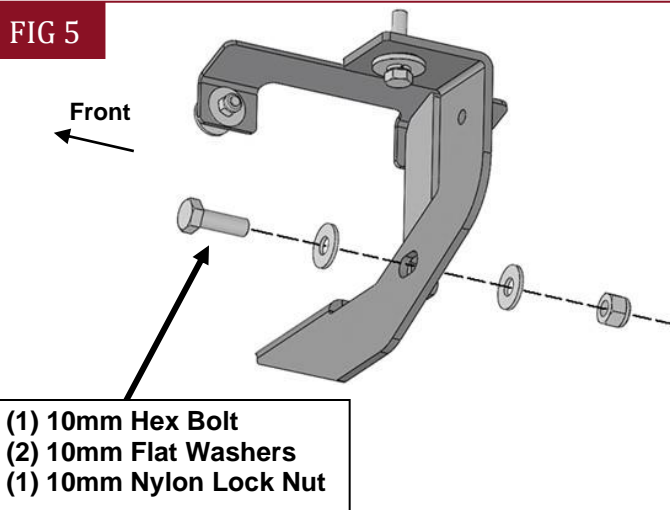

(Fig 5) Attach the Passenger/Right Front Support Bracket to the Mounting Bracket

STEP 4

Move to the center mounting location and locate the threaded insert and pair of holes in the pinch weld, (Fig 6). Repeat Steps 2 & 3 to attach the Passenger/Right Center Mounting Bracket and (1) Passenger/Right Center/Rear Support Bracket (#2), (Fig 7). **IMPORTANT:** The Center Mounting Brackets has an Oblique Cut on its top surface. Please identify the Front, Center, Rear Brackets according to the illustration on Part List. Do not tighten hardware.

FIG 6

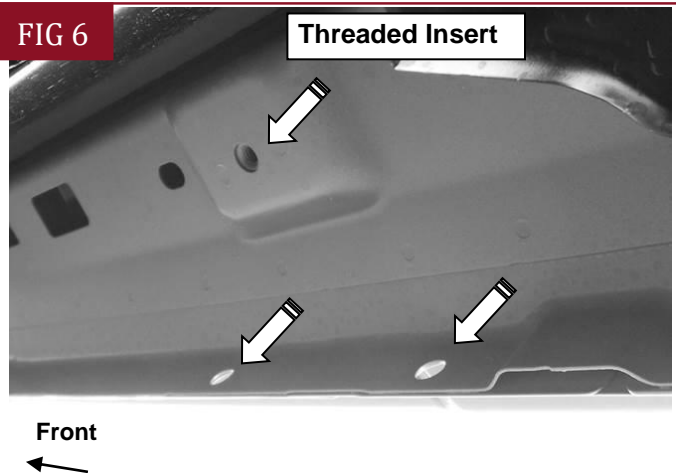

(Fig 6) Passenger/Right center mounting location

FIG 7

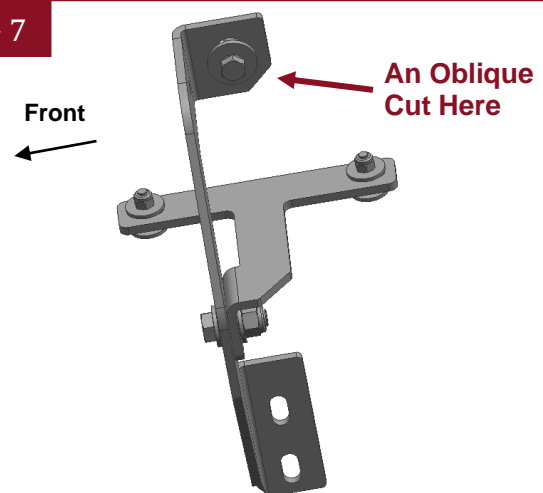

(Fig 7) Attach Passenger/Right Center Bracket and (1) Passenger/Right Center/Rear Support Bracket (#2) to the center location

STEP 5

Move to the rear mounting location on the rocker panel and locate the threaded insert and pair of holes in the pinch weld, **(Fig 8)**. Repeat **Steps 2 & 3** to attach the Passenger/Right Rear Mounting Bracket and (1) Center/Rear Support Bracket, **(Fig 9)**. **IMPORTANT: Please identify the Front, Center, Rear Brackets according to the illustration on Part List.** Do not tighten hardware.

FIG 8

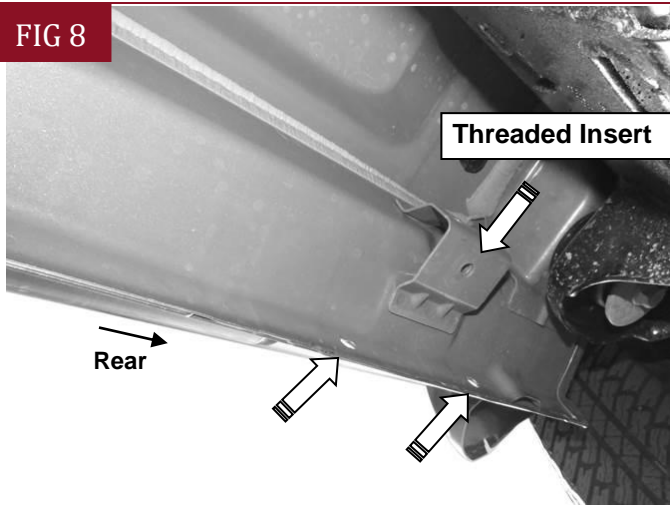

(Fig 8) Passenger/Right rear mounting location

FIG 9

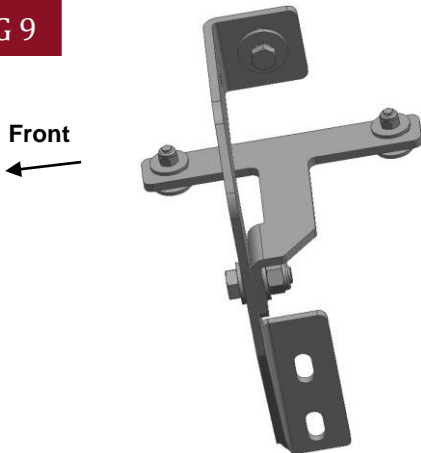

(Fig 9) Attach Passenger/Right Rear Bracket and (1) Passenger/Right Center/Rear Support Bracket (#2) to the rear location

STEP 6

Select the Passenger/Right Side Step. **NOTE: The Passenger/Right Side Step will have a Sticker "P" on the front.** Insert (6) 6mm T-Bolts into the channels in the bottom of the Side Step, **(Fig 10)**, (3 T-Bolts per channel). Attach the Step to the (3) Mounting Brackets with (6) 6mm Flat Washers, (6) 6mm Lock Washers and (6) 6mm Hex Nuts, **(Fig 11)**. Do not tighten hardware.

FIG 10

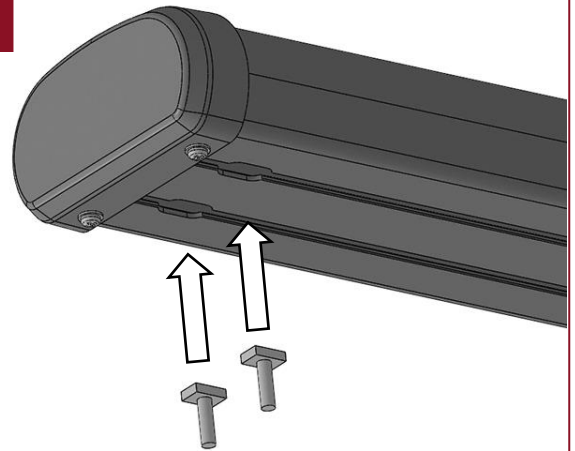

(Fig 10) Insert (6) 6mm T-Bolts into the channels in the bottom of the Side Step, (3 T-Bolts per channel)

FIG 11

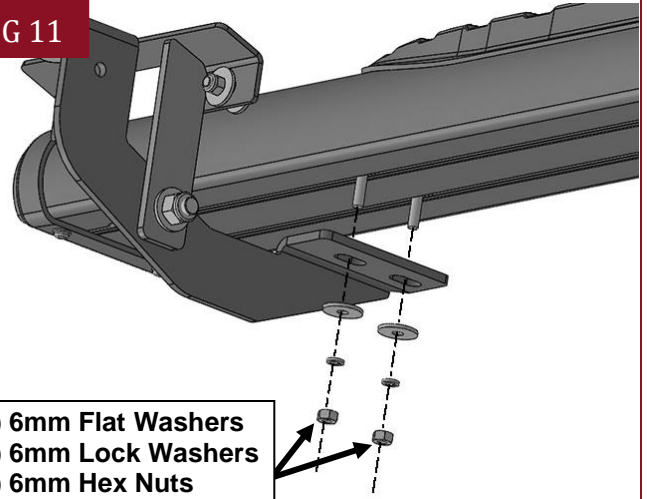

(Fig 11) Attach the Passenger/Right Side Step to the Mounting Brackets

STEP 7

Level and adjust the Side Step and tighten all hardware.

STEP 8

Repeat **Steps 1—7** to attach Driver/Left Side Step.

STEP 9

Do periodic inspections to the installation to make sure that all hardware is secure and tight.

Attention

To protect your investment, do not use any type of polish or wax that may contain abrasives that could damage the finish.

Mild soap may be used also to clean the Side Steps.