



ARROW SIDE STEP

PART #: TB-F18

FITS: 2021-Up Ford Bronco 4 Door



60-120 min



Cutting Not Required



Drilling Not Required

Torque & Tools

Fastener Size	Tightening Torque (ft-lbs)	Wrench Required		Allen Wrench Required	
			<input type="checkbox"/> 10mm		<input type="checkbox"/> 4mm
<input type="checkbox"/> 6mm	<input type="checkbox"/> 7-8.5		<input checked="" type="checkbox"/> 13mm		<input type="checkbox"/> 5mm
<input checked="" type="checkbox"/> 8mm	<input checked="" type="checkbox"/> 18-20		<input checked="" type="checkbox"/> 16mm		<input type="checkbox"/> 6mm
<input checked="" type="checkbox"/> 10mm	<input checked="" type="checkbox"/> 35-40		<input type="checkbox"/> 18mm		<input type="checkbox"/> 8mm
<input type="checkbox"/> 12mm	<input type="checkbox"/> 60-70				

BEFORE INSTALLATION

REMOVE CONTENTS FROM BOX. VERIFY ALL PARTS ARE PRESENT. READ INSTRUCTIONS CAREFULLY BEFORE STARTING INSTALLATION. ASSISTANCE IS RECOMMENDED.

Part List

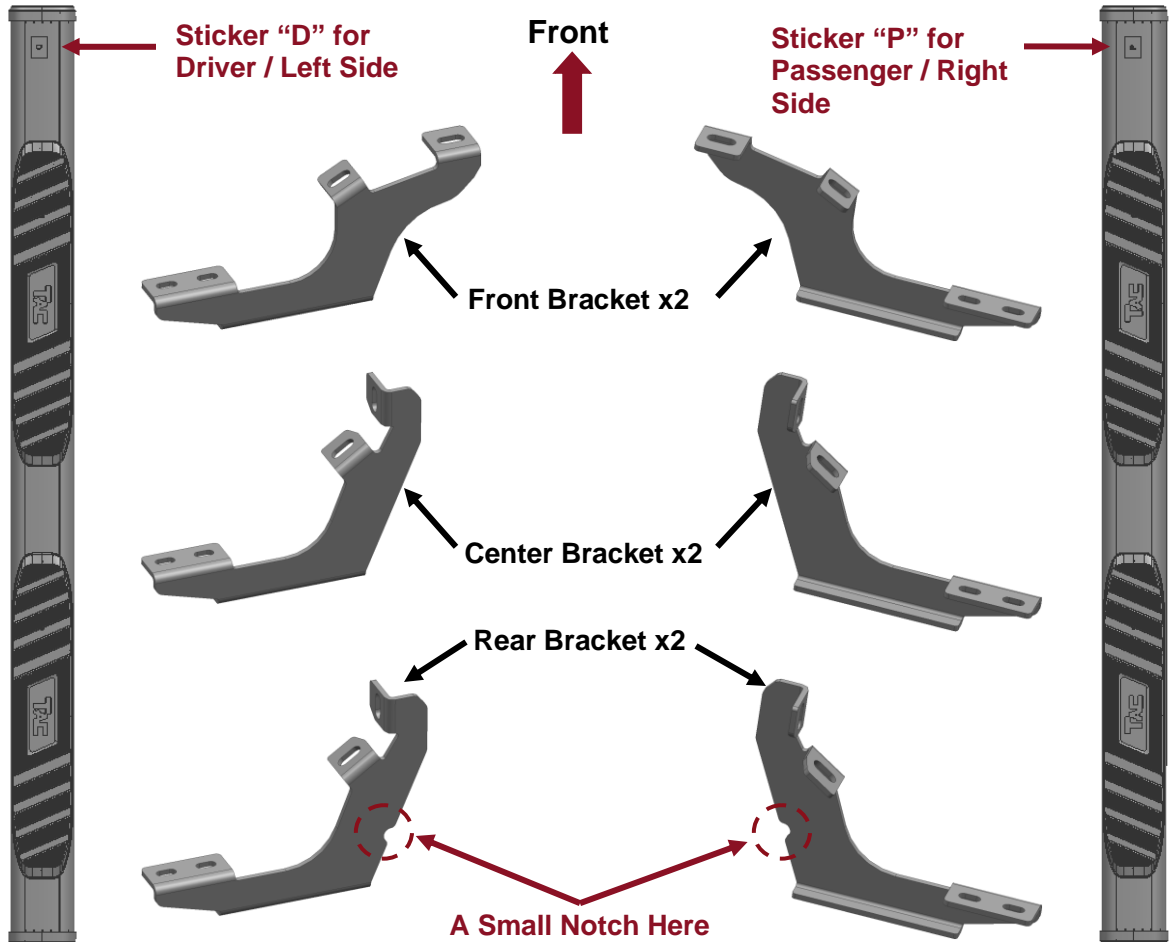

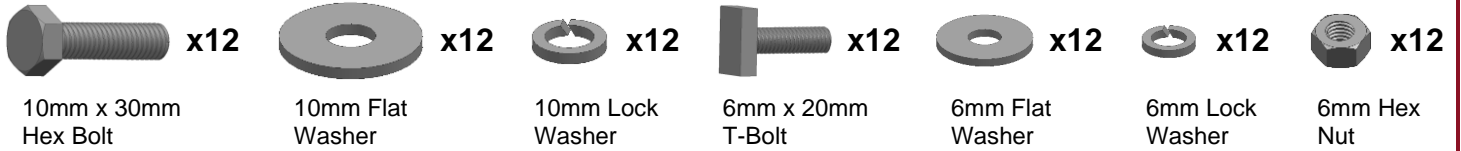

PLEASE NOTE THAT THE FOLLOWING PICTURES ARE BASED ON THE PASSENGER SIDE INSTALLATION

STEP 1

Starting from underneath the Passenger/Right body panel, locate the front mounting location and the threaded holes in the body panel, **(Fig 1)**. Remove the plastic plugs covering the holes.

FIG 1



(Fig 1) Passenger/Right front mounting location

STEP 2

Select (1) Front Mounting Bracket. Attach the Mounting Bracket to the Passenger/Right front location with (2) 10mm Hex Bolts, (2) 10mm Lock Washers and (2) 10mm Flat Washers, **(Fig 2)**. Do not tighten hardware.

FIG 2

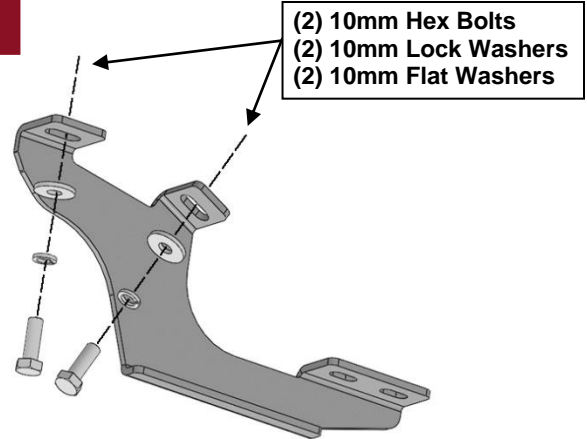

(Fig 2) Attach (1) Front Mounting Bracket to the Passenger/Right front location

STEP 3

Repeat **Steps 1-2** to attach (1) Center and (1) Rear Mounting Brackets to the center and rear locations, **(Figs 3-6)**. **NOTE: The Center and Rear Mounting Brackets are similar but unique. The Rear Mounting Bracket has a notch in the back, (Fig 4).** Do not tighten hardware.

FIG 3

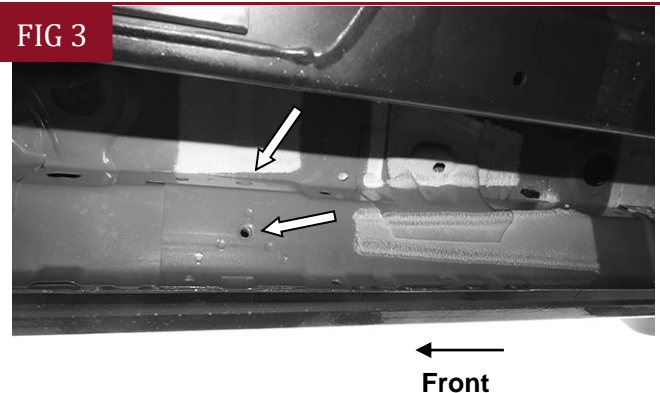

(Fig 3) Passenger/Right center mounting location

FIG 4

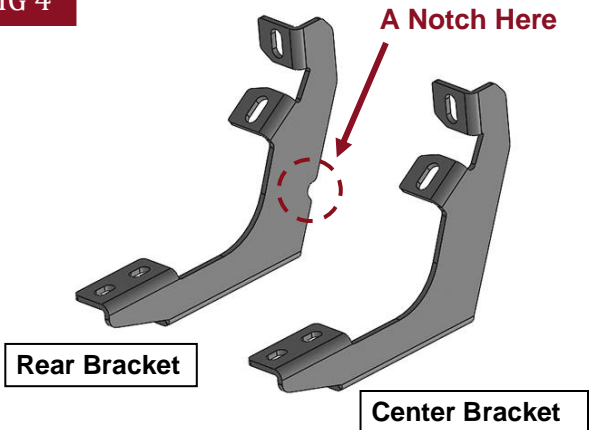

(Fig 4) The Center and Rear Mounting Brackets are similar but unique. The Rear Mounting Bracket has a notch in the back

FIG 5

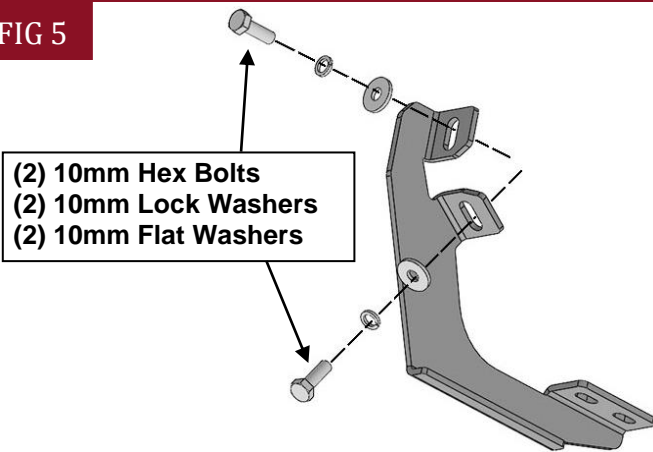

(Fig 5) Attach (1) Center Mounting Bracket to the center location

FIG 6

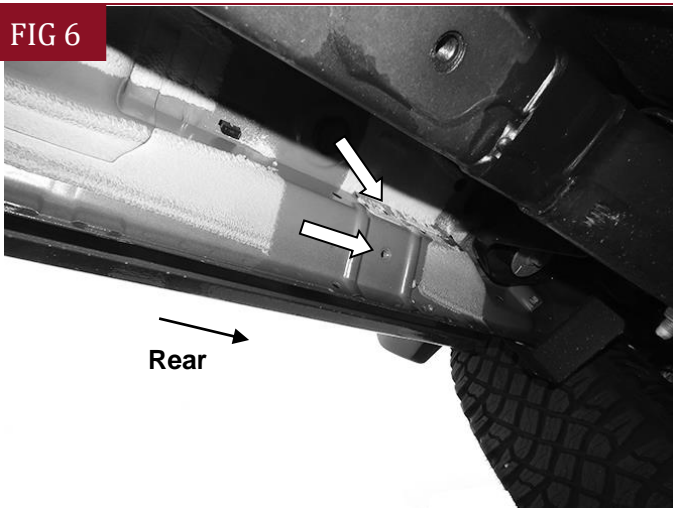

(Fig 6) Passenger/Right rear mounting location

STEP 4

Select the Passenger/Right Side Step. **NOTE:** The Passenger/Right Side Step have a Sticker "P" on the front. Insert (6) 6mm T-Bolts into the channels in the bottom of the Side Step, (Fig 7), (3 T-Bolts per channel). Attach the Side Step to the (3) Mounting Brackets with (6) 6mm Flat Washers, (6) 6mm Lock Washers and (6) 6mm Hex Nuts, (Fig 8). Do not tighten hardware.

FIG 7

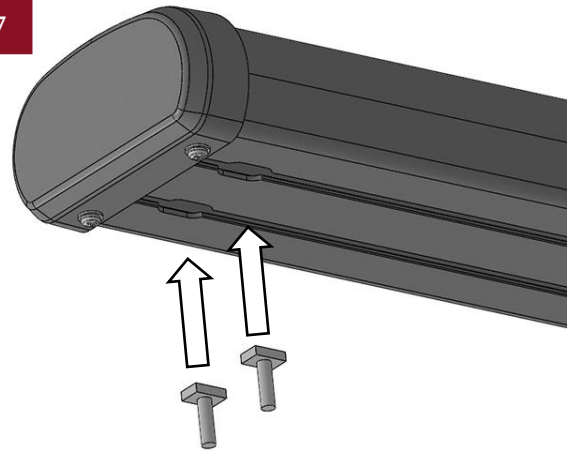

(Fig 7) Insert (6) 6mm T-Bolts into the channels in the bottom of the Side Step, (3 T-Bolts per channel)

FIG 8

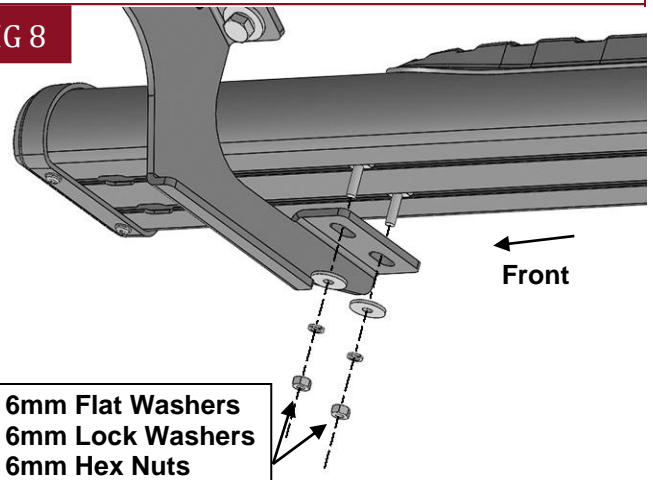

(Fig 8) Attach the Passenger/Right Side Step to the Mounting Brackets

STEP 5

Level and adjust the Side Step and fully tighten all hardware.

STEP 6

Repeat **Steps 1—5** to attach the Driver/Left Side Step.

STEP 7

Do periodic inspections to the installation to make sure that all hardware is secure and tight.

Attention

To protect your investment, do not use any type of polish or wax that may contain abrasives that could damage the finish.

Mild soap may be used also to clean the Side Steps.