



ARROW SIDE STEP

PART #: TB-F16

FITS: 2019-Up Ford Ranger Super Cab



60-120 min



Cutting Not Required



Drilling Not Required

Torque & Tools

Fastener Size	Tightening Torque (ft-lbs)	Wrench Required		Allen Wrench Required	
<input type="checkbox"/> 6mm	<input type="checkbox"/> 7-8.5		<input type="checkbox"/> 10mm		<input type="checkbox"/> 4mm
<input checked="" type="checkbox"/> 8mm	<input checked="" type="checkbox"/> 18-20		<input checked="" type="checkbox"/> 13mm		<input type="checkbox"/> 5mm
<input checked="" type="checkbox"/> 10mm	<input checked="" type="checkbox"/> 35-40		<input checked="" type="checkbox"/> 16mm		<input type="checkbox"/> 6mm
<input type="checkbox"/> 12mm	<input type="checkbox"/> 60-70		<input type="checkbox"/> 18mm		<input type="checkbox"/> 8mm

BEFORE INSTALLATION

REMOVE CONTENTS FROM BOX. VERIFY ALL PARTS ARE PRESENT. READ INSTRUCTIONS CAREFULLY BEFORE STARTING INSTALLATION. ASSISTANCE IS RECOMMENDED.

Part List

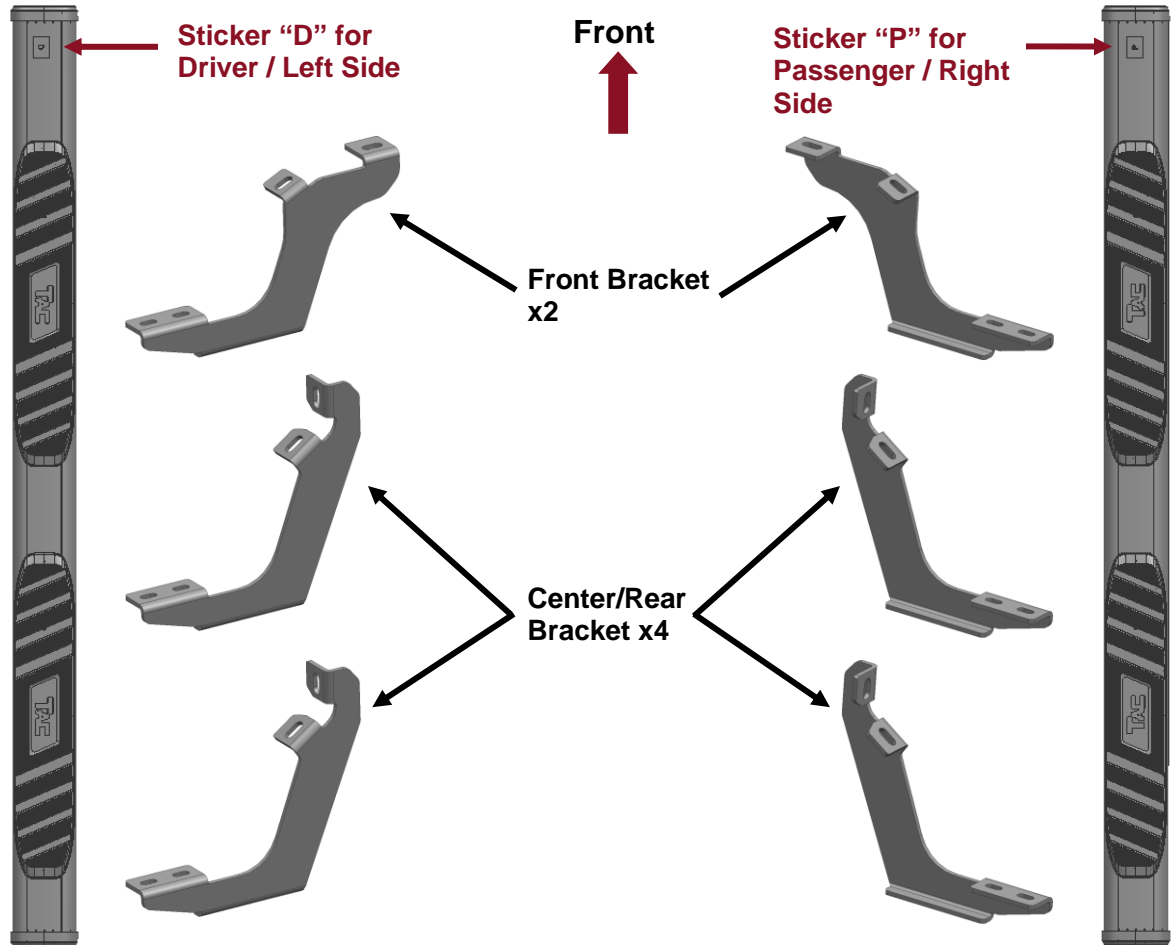

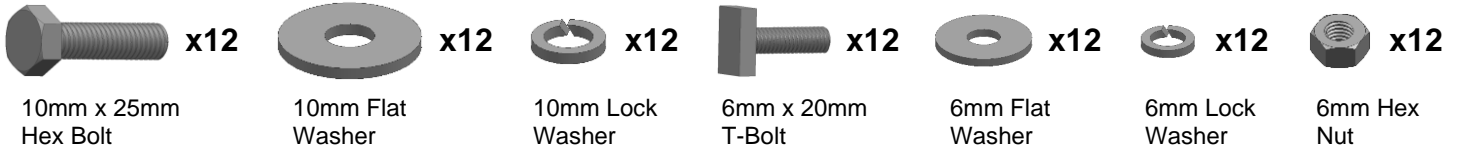

PLEASE NOTE THAT THE FOLLOWING PICTURES ARE BASED ON THE DRIVER SIDE INSTALLATION

STEP 1

Starting from underneath the Driver/Left body panel, locate the front mounting location and the threaded holes in the body panel, **(Fig 1)**. Remove the plastic plugs covering the holes.

FIG 1

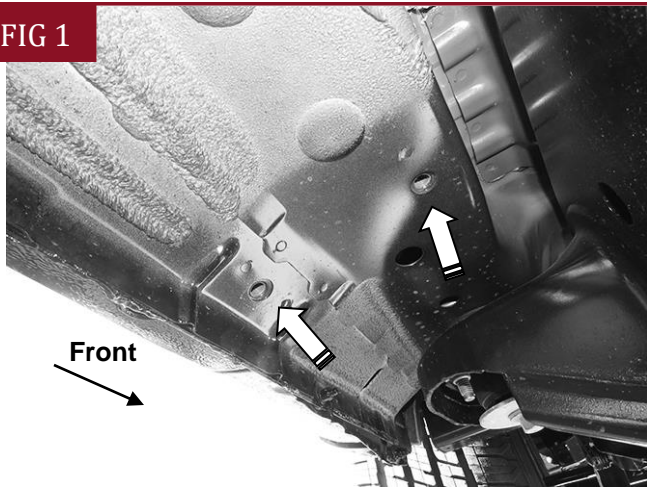

(Fig 1) Driver/Left front mounting location

STEP 2

Select the Front Mounting Bracket. Attach the Mounting Bracket to the front location with (2) 10mm Hex Bolts, (2) 10mm Lock Washers and (2) 10mm Flat Washers, **(Fig 2)**. Do not tighten hardware.

FIG 2

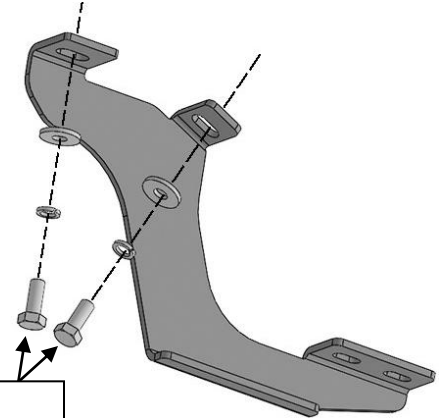

(2) 10mm Hex Bolts
(2) 10mm Lock Washers
(2) 10mm Flat Washers

(Fig 2) Attach the (1) Front Mounting Bracket to the front location

STEP 3

Repeat **Steps 1-2** to attach (2) Center/Rear Mounting Brackets to the center and rear locations, **(Figs 3-5)**. Do not tighten hardware.

FIG 3

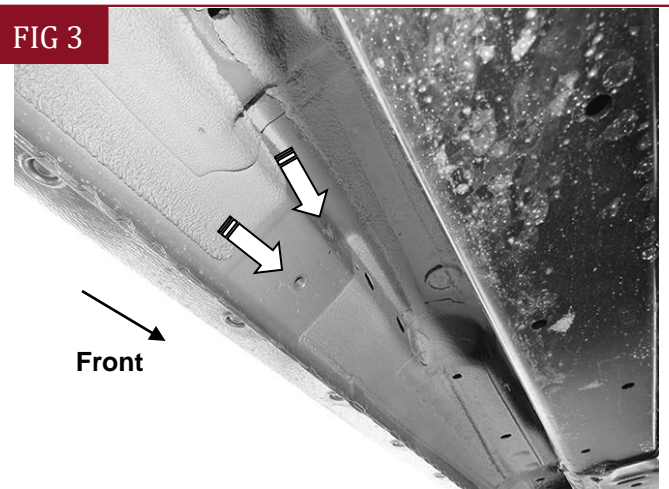

(Fig 3) Driver/Left center mounting location

FIG 4

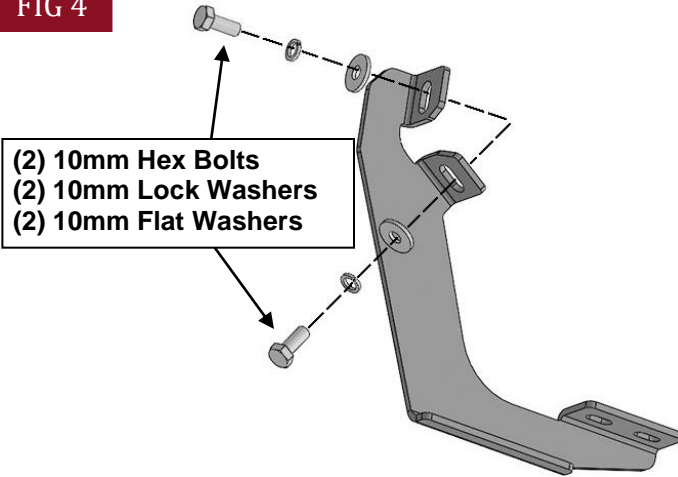

(Fig 4) Attach (1) Center/Rear Mounting Bracket to the rocker panel

FIG 5

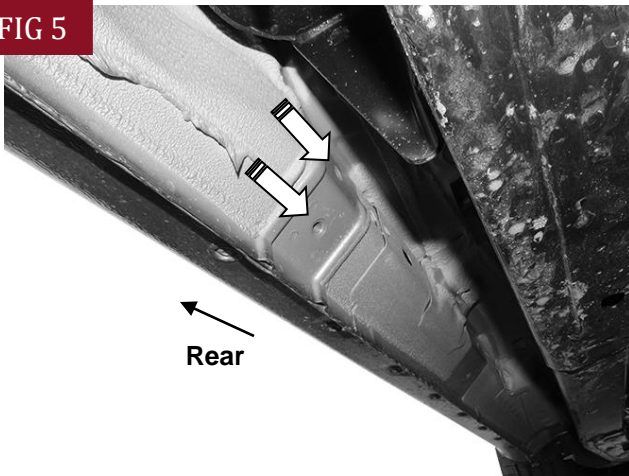

(Fig 5) Driver/Left rear mounting location

FIG 6

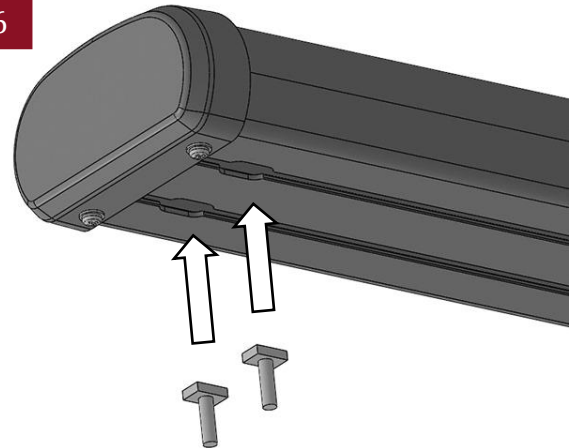

(Fig 6) Insert (6) 6mm T-Bolts into the channels in the bottom of the Side Step, (3 T-Bolts per channel)

FIG 7

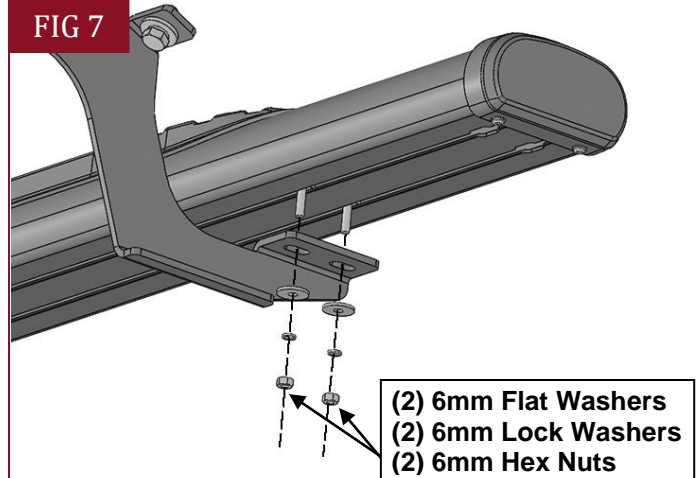

(Fig 7) Attach the Driver/Left Side Step to the Mounting Brackets

STEP 4

Select the Driver/Left Side Step. **NOTE: The Driver/Left Side Step have a Sticker "D" on the front.** Insert (6) 6mm T-Bolts into the channels in the bottom of the Side Step, (**Fig 6**), (3 T-Bolts per channel). Attach the Side Step to the (3) Mounting Brackets with (6) 6mm Flat Washers, (6) 6mm Lock Washers and (6) 6mm Hex Nuts, (**Fig 7**). Do not tighten hardware.

STEP 5

Level and adjust the Side Step and fully tighten all hardware.

STEP 6

Repeat **Steps 1—5** to attach the Passenger/Right Side Step.

STEP 7

Do periodic inspections to the installation to make sure that all hardware is secure and tight.

Attention

To protect your investment, do not use any type of polish or wax that may contain abrasives that could damage the finish.

Mild soap may be used also to clean the Side Steps.