



# ARROW SIDE STEP

PART #: TB-D11N

**FITS:**

2019-Up Dodge RAM 1500 Crew Cab  
(Exclude 2019-2024 RAM 1500 **Classic** Crew Cab)



60-120 min



Cutting Not Required



Drilling Not Required

## Torque & Tools

Fastener Size	Tightening Torque (ft-lbs)	Wrench Required		Allen Wrench Required	
			<input checked="" type="checkbox"/> 10mm		<input type="checkbox"/> 4mm
<input checked="" type="checkbox"/> 6mm	<input checked="" type="checkbox"/> 7-8.5		<input checked="" type="checkbox"/> 13mm		<input type="checkbox"/> 5mm
<input checked="" type="checkbox"/> 8mm	<input checked="" type="checkbox"/> 18-20		<input type="checkbox"/> 16mm		<input type="checkbox"/> 6mm
<input type="checkbox"/> 10mm	<input type="checkbox"/> 35-40		<input type="checkbox"/> 18mm		<input type="checkbox"/> 8mm
<input type="checkbox"/> 12mm	<input type="checkbox"/> 60-70				

### BEFORE INSTALLATION

REMOVE CONTENTS FROM BOX. VERIFY ALL PARTS ARE PRESENT. READ INSTRUCTIONS CAREFULLY BEFORE STARTING INSTALLATION. ASSISTANCE IS RECOMMENDED.

### Part List



Sticker "D" for Driver / Left Side

Front ↑

Sticker "P" for Passenger / Right Side

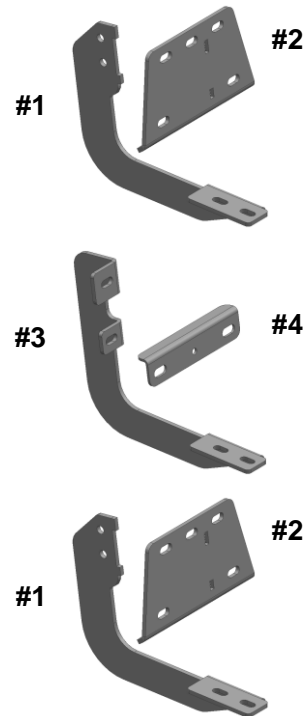
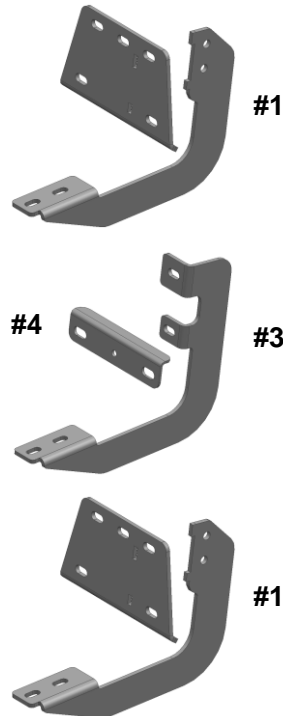

- #1: Front/Rear Lower Mounting Bracket x 4
- #2: Front/Rear Upper Mounting Bracket x 4
- #3: Center Mounting Bracket x 2
- #4: Center Support Bracket x 2

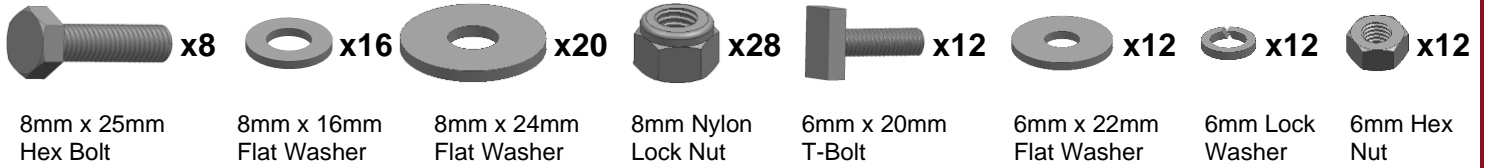

**PLEASE NOTE THAT THE FOLLOWING PICTURES ARE BASED ON THE DRIVER SIDE INSTALLATION**

## STEP 1

Start the installation under the Driver/Left side of the vehicle. Locate the front (3) factory studs along the inner side of the body panel, **(Fig 1)**.

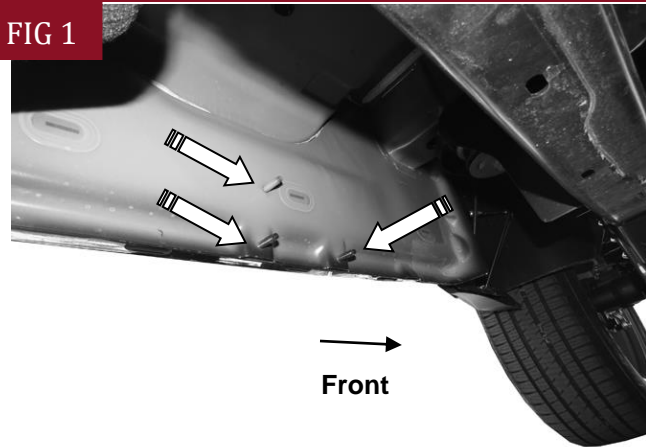

**(Fig 1) Driver/Left Front mounting location**

## STEP 2

Select (1) Front/Rear Upper Mounting Bracket **(#2)**. Attach the Mounting Bracket to the (3) factory studs with (3) 8mm x 24mm Flat Washers and (3) 8mm Nylon Lock Nuts, **(Fig 2)**. Do not tighten hardware.

**FIG 2**

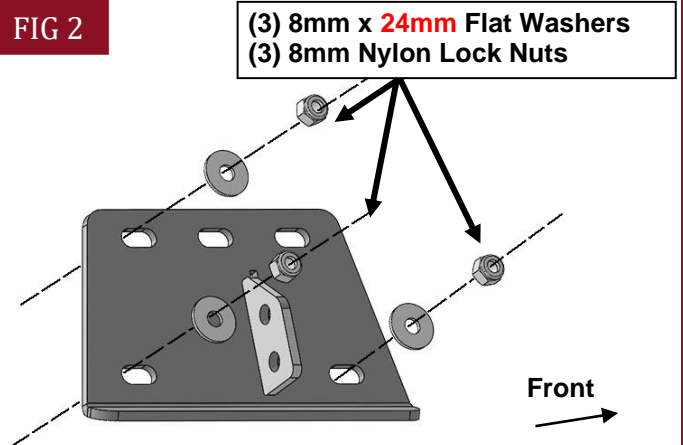

**(Fig 2) Attach (1) Front/Rear Upper Mounting Bracket (#2) to the threaded studs**

## STEP 3

Attach (1) Front/Rear Lower Mounting Bracket **(#1)** to the welded plate on the back of the Front Upper Bracket **(#2)** with (2) 8mm Hex Bolts, (4) 8mm x 16mm Flat Washer, and (2) 8mm Nylon Lock Nuts **(Fig 3)**.

**FIG 3**

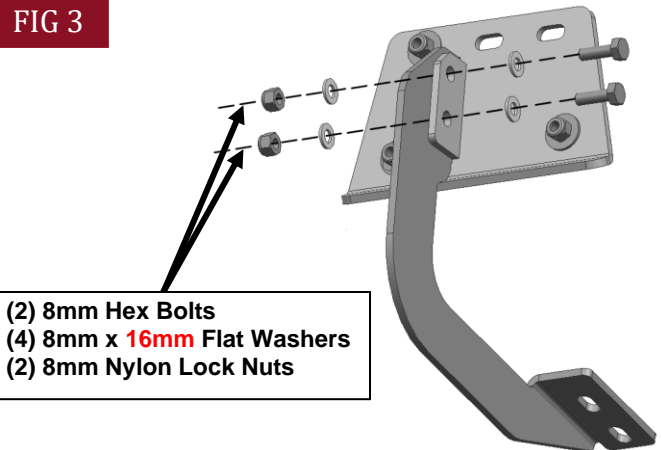

**(Fig 3) Driver/Left Front mounting location**

## STEP 4

Move to the center location, **(Fig 4)**. Select (1) Center Support Bracket **(#4)**, attach the Support Bracket to the lower (2) factory studs with (2) 8mm x 24mm Flat Washers and (2) 8mm Nylon Lock Nuts, **(Fig 5)**.

FIG 4

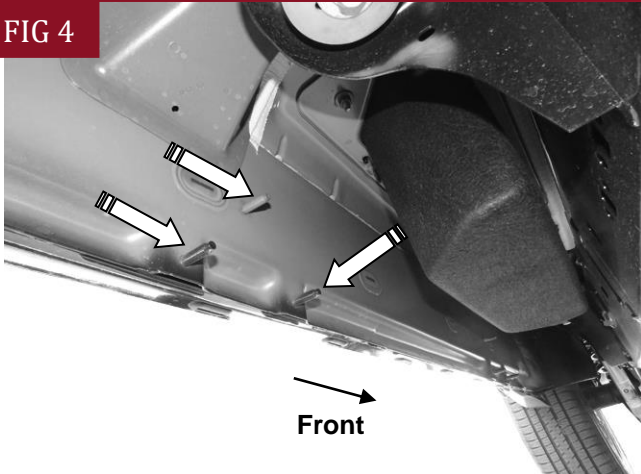

**(Fig 4) Driver/Left Center mounting location**

FIG 5

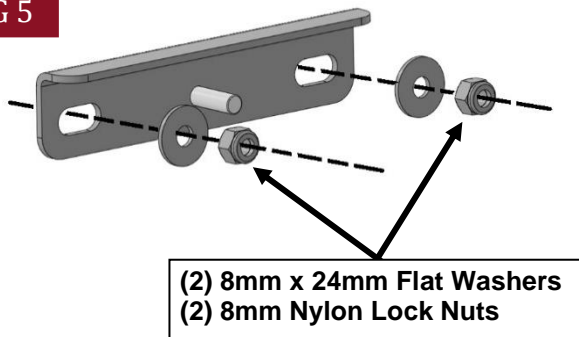

**(Fig 5) Attach (1) Center Support Bracket (#4) to the lower (2) threaded studs on the mounting location**

## STEP 5

Select (1) Center Mounting Bracket **(#3)** and attach to the Support Bracket and upper threaded stud with (2) 8mm x 24mm Flat Washers and (2) 8mm Nylon Lock Nuts, **(Fig 6)**. Do not tighten hardware.

FIG 6

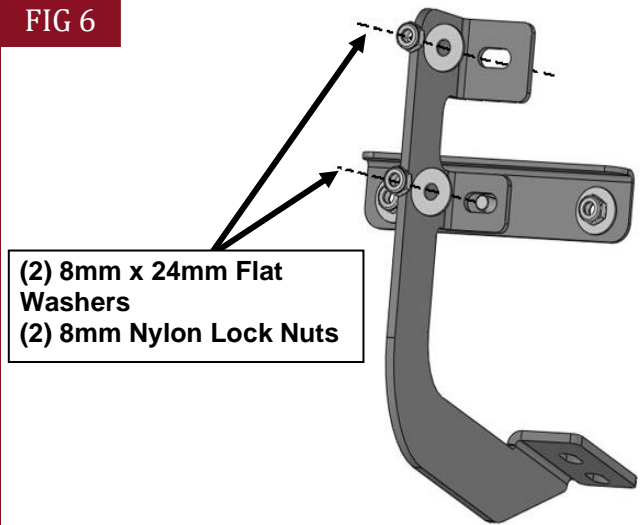

**(Fig 6) Attach Mounting Bracket to the upper mounting stud and Support Bracket**

## STEP 6

Repeat **Steps 2 & 3** to attach (1) Front/Rear Upper Mounting Bracket **(#2)** and (1) Front/Rear Lower Mounting Bracket **(#1)** to the rear mounting locations along the body panel, **(Fig 7)**. Do not tighten hardware.

FIG 7

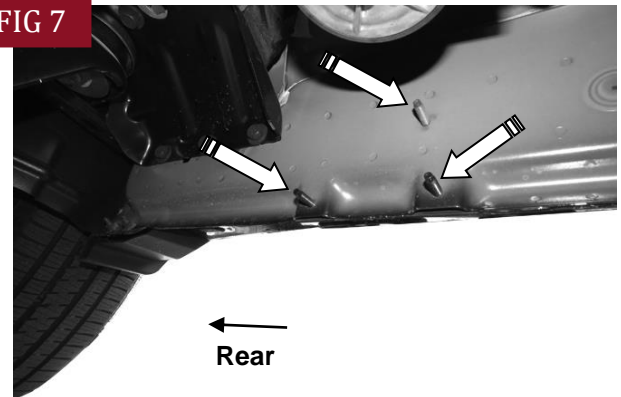

**(Fig 7) Driver/Left Rear mounting location**

## STEP 7

Select the Driver/Left Side Step. Insert (6) 6mm T-Bolts into the slots underneath the Side Step (**Fig 8**). **NOTE: The Driver/Left Side Step will have a Sticker "D" on the front.** **IMPORTANT:** Do not slide the Side Step front to back or damage to the finish may result. Attach the Side Step to the (3) Mounting Brackets with (6) 6mm Flat Washers, (6) 6mm Lock Washers, and (6) 6mm Hex Nuts (**Fig 9**). Do not tighten hardware.

FIG 8

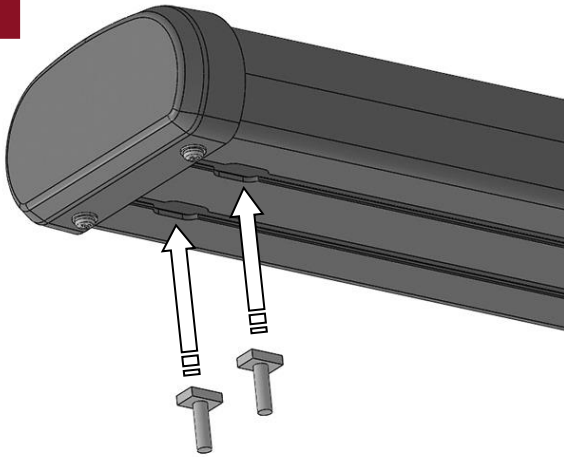

(Fig 8) Insert (6) 6mm T-Bolts into the slot underneath the Side Step

FIG 9

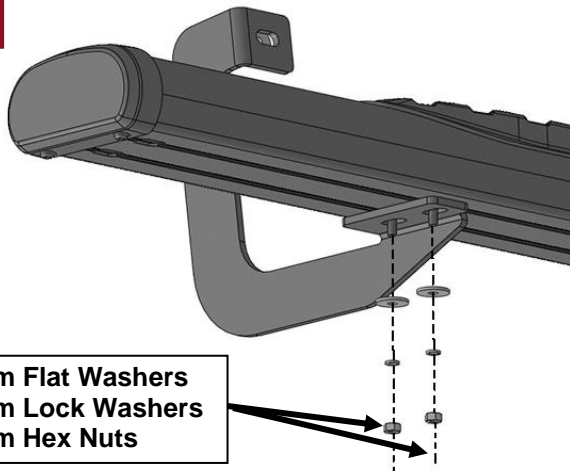

(2) 6mm Flat Washers  
(2) 6mm Lock Washers  
(2) 6mm Hex Nuts

(Fig 9) Attach Side Step to the Mounting Brackets

## STEP 8

Level and adjust the Side Step as necessary and fully tighten all hardware.

## STEP 9

Repeat **Steps 1-8** to attach the Passenger/Right Side Step to the vehicle.

## STEP 10

Do periodic inspections to the installation to make sure that all hardware is secure and tight.

### Attention

To protect your investment, do not use any type of polish or wax that may contain abrasives that could damage the finish.

Mild soap may be used also to clean the Side Steps.