



# ARROW SIDE STEP

PART #: TB-D09

**FITS:**

2009-2018 Dodge RAM 1500 Quad Cab  
 2019-2023 Dodge RAM 1500 **Classic** Model Quad Cab



60-120 min



Cutting Not Required



Drilling May Required

## Torque & Tools

Fastener Size	Tightening Torque (ft-lbs)	Wrench Required		Allen Wrench Required	
			<input checked="" type="checkbox"/> 10mm		<input type="checkbox"/> 4mm
<input checked="" type="checkbox"/> 6mm	<input checked="" type="checkbox"/> 7-8.5		<input checked="" type="checkbox"/> 13mm		<input type="checkbox"/> 5mm
<input checked="" type="checkbox"/> 8mm	<input checked="" type="checkbox"/> 18-20		<input type="checkbox"/> 16mm		<input type="checkbox"/> 6mm
<input type="checkbox"/> 10mm	<input type="checkbox"/> 35-40		<input type="checkbox"/> 18mm		<input type="checkbox"/> 8mm
<input type="checkbox"/> 12mm	<input type="checkbox"/> 60-70				

### BEFORE INSTALLATION

REMOVE CONTENTS FROM BOX. VERIFY ALL PARTS ARE PRESENT. READ INSTRUCTIONS CAREFULLY BEFORE STARTING INSTALLATION. ASSISTANCE IS RECOMMENDED.

### Part List

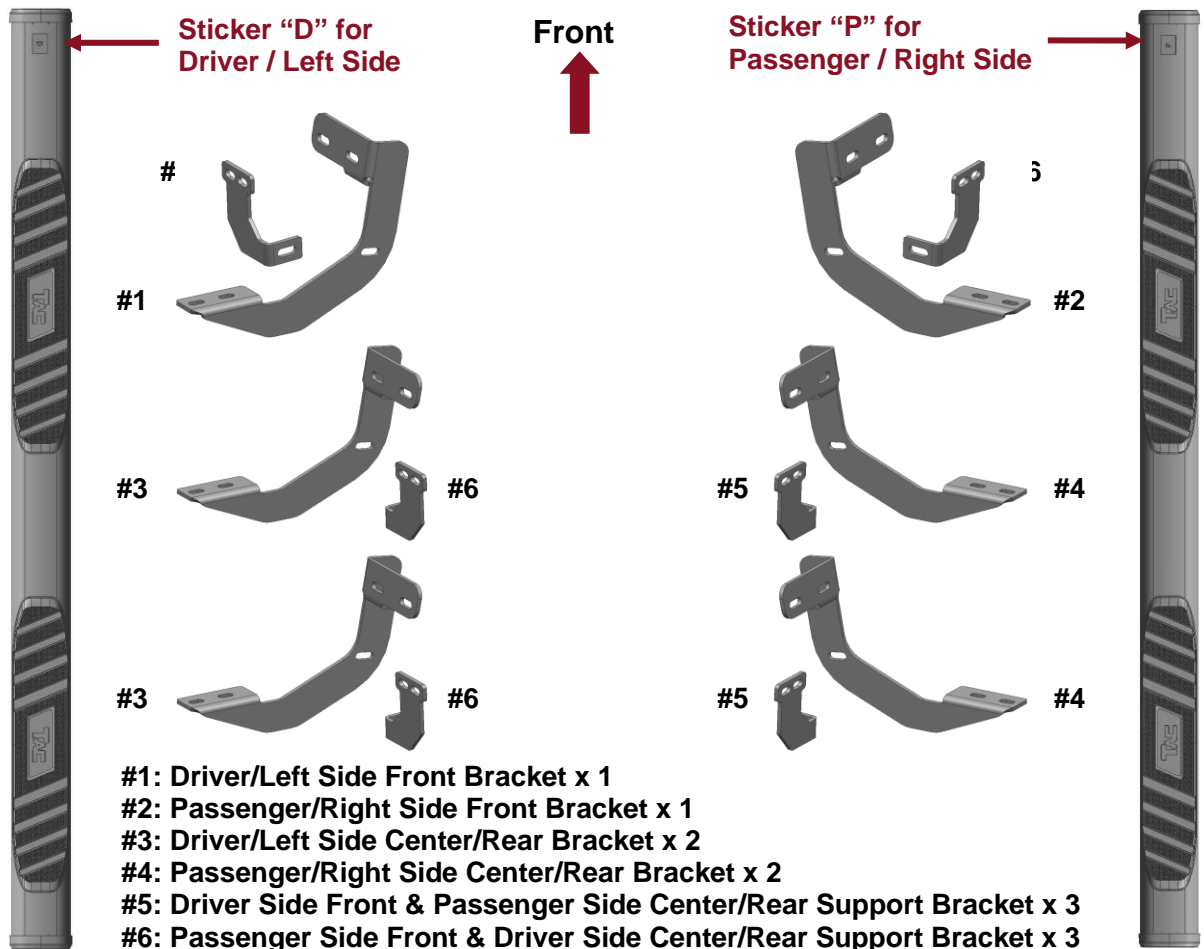

- #1: Driver/Left Side Front Bracket x 1
- #2: Passenger/Right Side Front Bracket x 1
- #3: Driver/Left Side Center/Rear Bracket x 2
- #4: Passenger/Right Side Center/Rear Bracket x 2
- #5: Driver Side Front & Passenger Side Center/Rear Support Bracket x 3
- #6: Passenger Side Front & Driver Side Center/Rear Support Bracket x 3

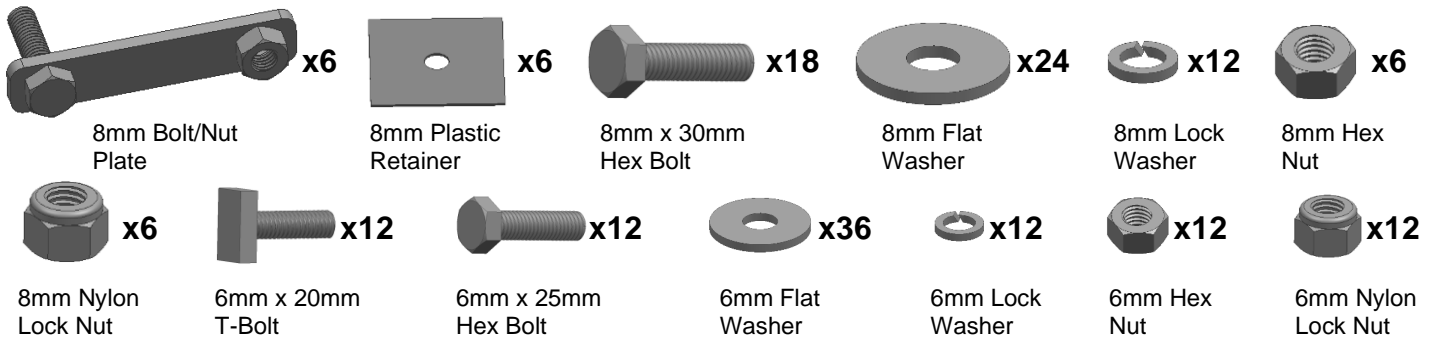

**PLEASE NOTE THAT THE FOLLOWING PICTURES ARE BASED ON THE DRIVER SIDE INSTALLATION**

## STEP 1

Starting at the driver side-front of the vehicle, remove the sealing tape covering the factory holes in the side of the inner panel, (Fig 1).

FIG 1

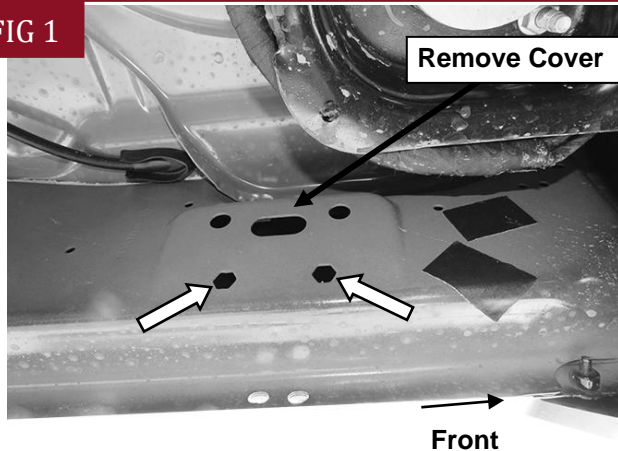

(Fig 1) 2009-mid 2015 driver front mounting location (No factory holes in pinch weld on 2009-2012 models). The two small hex holes are mounting holes, the large slot hole is required to assist installation.

## STEP 2.1

Determine the correct procedure to attach the driver side front Bracket for your model/year:

### Models without factory threaded inserts in body panel:

- a. Select (1) 8mm Bolt/nut Plate. Partially thread an 8mm Hex Bolt onto the threaded of the Nut Plate. Thread the Hex Bolt in until it is flush with the welded nut. Use the Hex Bolt as a handle and insert the Bolt and Nut Plate into the oval hole, (Fig 2). Feed the threaded bolt on the Bolt Plate through one of the hex shaped factory holes.

FIG 2

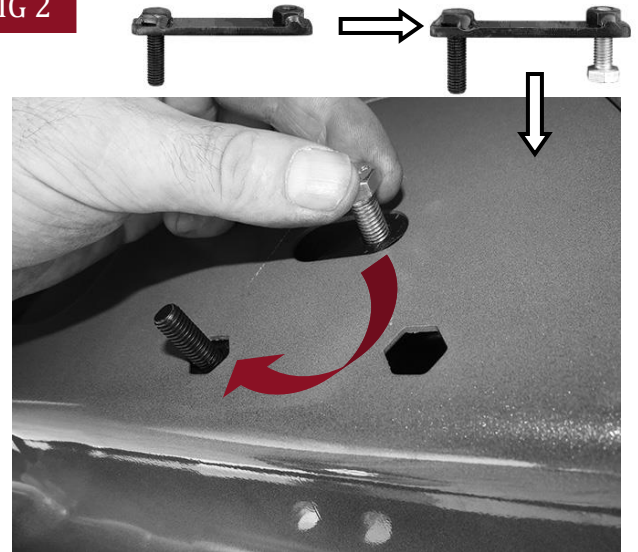

(Fig 2) Insert 8mm Bolt/Nut Plate (NOTE: 8mm Bolt-Nut Plate is not required on models with threaded inserts). **IMPORTANT: Do not let go of the hex bolt until after Plastic Retainer has been threaded onto bolt (Fig 3)**

- b. Thread (1) 8mm Plastic Retainer onto the threaded end and down tight against the body panel, **(Fig 3)**. **NOTE: The Plastic Retainer is designed to keep the Bolt/Nut Plate from falling into the body panel and to aid in Bracket installation.**

**FIG 3**

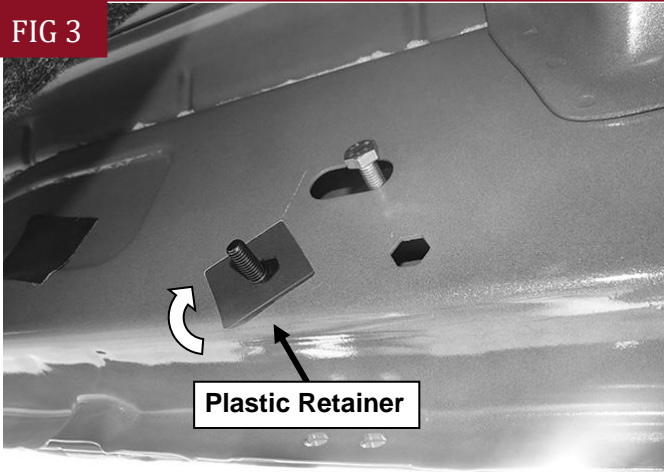

**(Fig 3) Thread Plastic Retainer onto Bolt Plate to hold Bolt Plate in position.**

- c. Select (1) Driver/Left Front Bracket (#1). Attach the Bracket to the threaded end of the Bolt Plate with (1) 8mm Flat Washer, (1) 8mm Lock washer and (1) 8mm Hex Nut, **(Fig 4)**. Do not tighten hardware at this time.

**FIG 4**

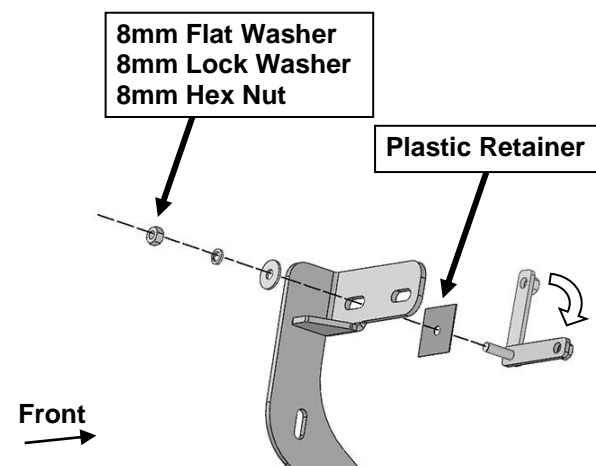

**(Fig 4) Attach the bracket to the Bolt/Nut Plate. Then Remove 8mm Hex Bolt. Rotate Bolt Plate to line up with remaining factory hex shaped hole.**

- d. Remove the 8mm Hex Bolt from the nut on the Bolt Plate from **Step 2.1a**. Rotate the Bolt on the Bolt Plate until the threaded nut lines up with the remaining hole in the Mounting Bracket and body panel, **(Fig 4)**. Attach the Bracket to the threaded Nut Plate with (1) 8mm x 30mm Hex Bolt, (1) 8mm Lock Washer and (1) 8mm Flat Washer, **(Fig 5)**. Do not tighten hardware.

**FIG 5**

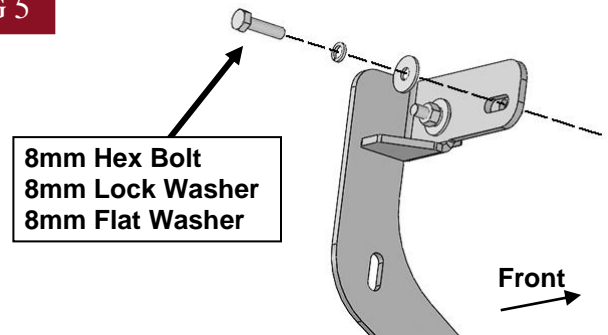

**(Fig 5) Attach Bracket to threaded end of Bolt Plate**

## STEP 2.2

### Models with factory threaded inserts:

- a. Attach (1) Driver/Left Front Bracket (#1) to the threaded inserts with (2) 8mm x 30mm Hex Bolts, (2) 8mm Lock Washers and (2) 8mm Flat Washer, **(Figs 6 & 7)**. Do not tighten hardware.

**FIG 6**

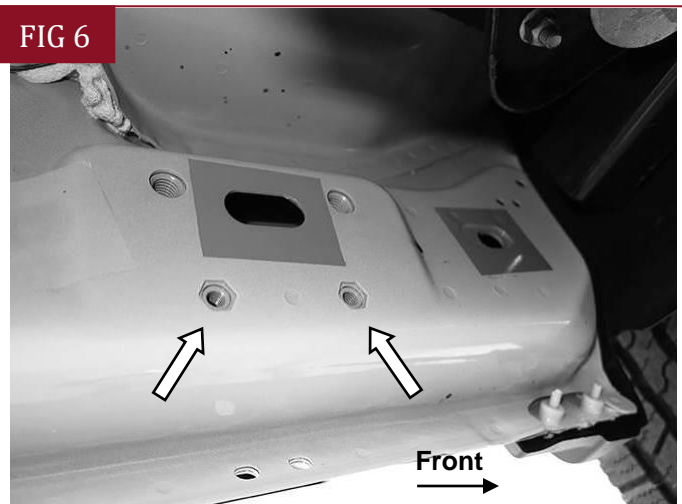

**(Fig 6) Driver/left side front mid 2015-on (example of models with factory installed threaded inserts)**

FIG 7

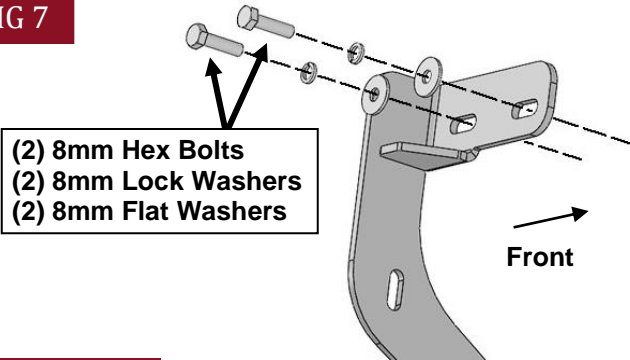

(Fig 7) Driver/left side front models with factory installed threaded inserts. **Bolt Plate not required**

## STEP 3

Select (1) Driver/Left Front Support Bracket (#5). Attach the Bracket to the back of the pinch weld with (2) 6mm Hex Bolts, (4) 6mm Flat Washers and (2) 6mm Flange Nuts, (Fig 8). Do not fully tighten hardware at this time. **IMPORTANT: 2009-12 models not equipped with factory holes will require drilling through the pinch weld to fully attach Bracket. Do not drill through pinch weld at this time, (see Step 8).**

FIG 8

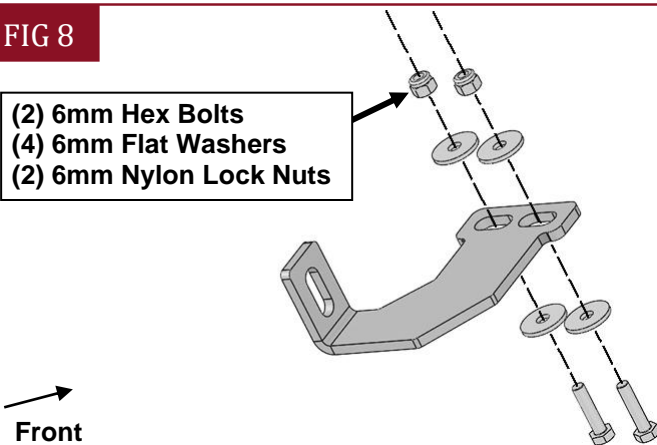

(Fig 8) Attach the Bracket to back of pinch weld (models with factory holes in pinch weld only)

### Attention:

2009-2012 models without holes in pinch weld will require drilling 1/4" holes through pinch weld to attach the bracket. Do complete installation of Side Steps first, level Side Step before drilling holes for bracket.

## STEP 4

Attach the Support Bracket to the Mounting Bracket with (1) 8mm Hex Bolt, (2) 8mm Flat Washers and (1) 8mm Nylon Lock Nut, (Fig 9).

FIG 9

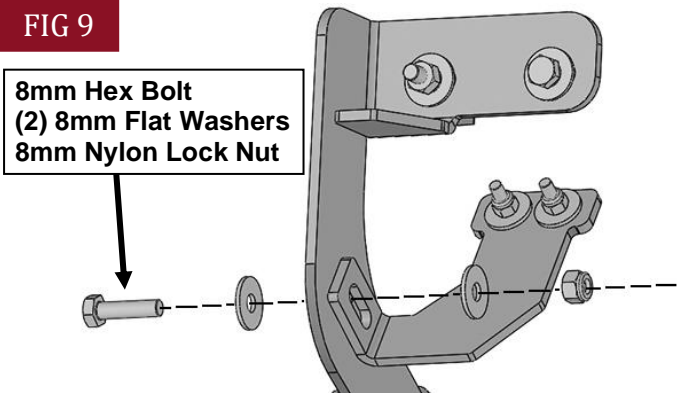

(Fig 9) Attach the Support Bracket to back of pinch weld (models with factory holes in pinch weld only)

## STEP 5

Move along the side of the body panel to the center mounting location, (Fig 10). Repeat Steps 1-4 to install (1) Driver/Left Center/Rear Mounting Bracket (#3) and (1) Driver Side Center/Rear Support Bracket (#6) to the center mounting location.

FIG 10

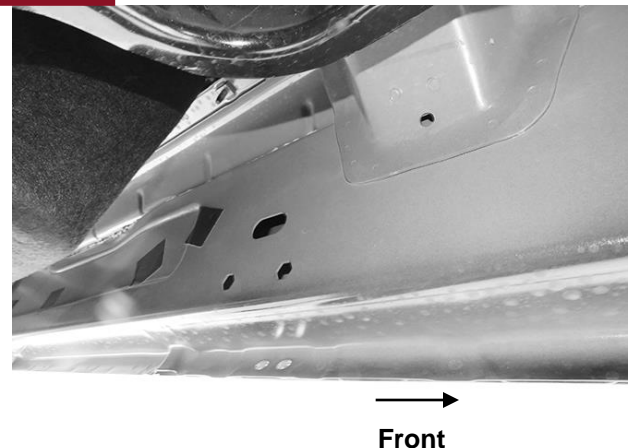

(Fig 10) Driver/left side center location

## STEP 6

Move to the rear location, (**Fig 11**). Repeat **Steps 1-4** to attach (1) Driver/Left Center/Rear Mounting Bracket (**#3**) and (1) Driver Side Center/Rear Support Bracket (**#6**) to the Driver/Left rear mounting location.

FIG 11



(Fig 11) Driver/left rear mounting location

## STEP 7

Select the Driver/Left Side Step. **NOTE: The Driver/Left Side Step will have a Sticker "D" on the front.** Insert (6) 6mm T-Bolts into the channels in the bottom of the Side Step, (**Fig 12**), (3 T-Bolts per channel). Attach the Step to the (3) Mounting Brackets with (6) 6mm Flat Washers, (6) 6mm Lock Washers and (6) 6mm Hex Nuts, (**Fig 13**). Do not tighten hardware.

FIG 12

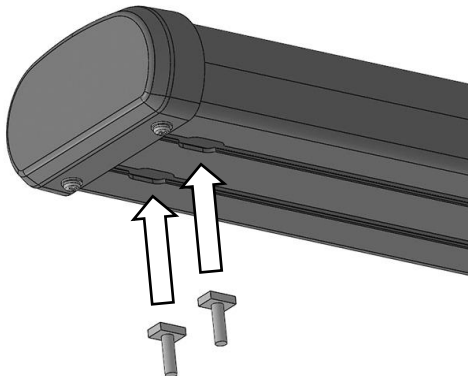

(Fig 12) Insert (6) 6mm T-Bolts into the channels in the bottom of the Side Step, (3 T-Bolts per channel)

FIG 13

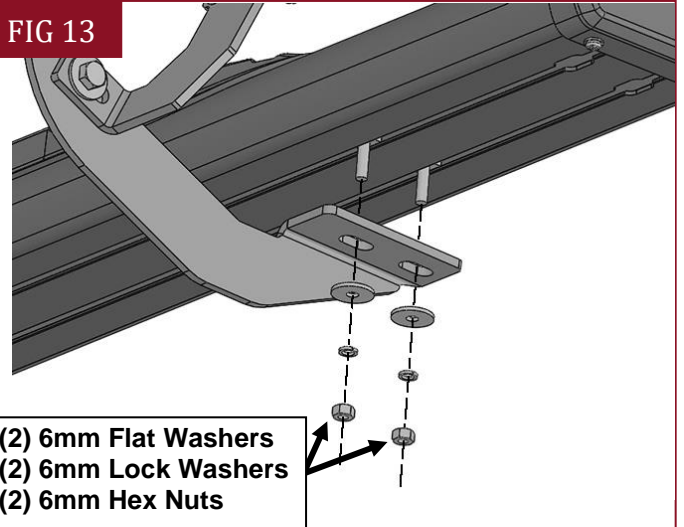

(2) 6mm Flat Washers  
(2) 6mm Lock Washers  
(2) 6mm Hex Nuts

(Fig 13) Attach the Driver/Left Side Step to the (3) Mounting Brackets

## STEP 8

Properly level and adjust the Side Step and fully tighten all hardware.

### 2009-12 models requiring drilling through pinch trim:

- Level the Side Step to the vehicle. Make sure all (3) Brackets are tight against the bottom of the body panel and tighten all mounting hardware.
- Mark the location of the slots onto the pinch weld.
- Drill (2) 1/4" holes through the pinch weld for each Bracket. **IMPORTANT: Do not drill too close to the bottom edge of the pinch weld. Drill the holes in the center of the marked slots.**
- Repeat **Step 3** to attach the Brackets to the drilled holes in the pinch weld. Check for level then fully tighten all hardware.

---

## STEP 9

Repeat **Steps 1-8** to attach the Passenger/Right Side Step.

---

## STEP 10

Do periodic inspections to the installation to make sure that all hardware is secure and tight.

### Attention

To protect your investment, do not use any type of polish or wax that may contain abrasives that could damage the finish.

Mild soap may be used also to clean the Side Steps.