



Rocker Step

PART #: TAC-TRS-027

FITS: 2005-Up Toyota Tacoma Double Cab



60-120 min



Cutting Not Required



Drilling Not Required

Torque & Tools

Fastener Size	Tightening Torque (ft-lbs)	Wrench Required		Allen Wrench Required	
			<input type="checkbox"/> 10mm		<input type="checkbox"/> 4mm
<input type="checkbox"/> 6mm	<input type="checkbox"/> 7-8.5		<input checked="" type="checkbox"/> 13mm		<input type="checkbox"/> 5mm
<input checked="" type="checkbox"/> 8mm	<input checked="" type="checkbox"/> 18-20		<input type="checkbox"/> 16mm		<input type="checkbox"/> 6mm
<input type="checkbox"/> 10mm	<input type="checkbox"/> 35-40		<input type="checkbox"/> 18mm		<input type="checkbox"/> 8mm
<input type="checkbox"/> 12mm	<input type="checkbox"/> 60-70				

BEFORE INSTALLATION

REMOVE CONTENTS FROM BOX. VERIFY ALL PARTS ARE PRESENT. READ INSTRUCTIONS CAREFULLY BEFORE STARTING INSTALLATION. ASSISTANCE IS RECOMMENDED.

Part List

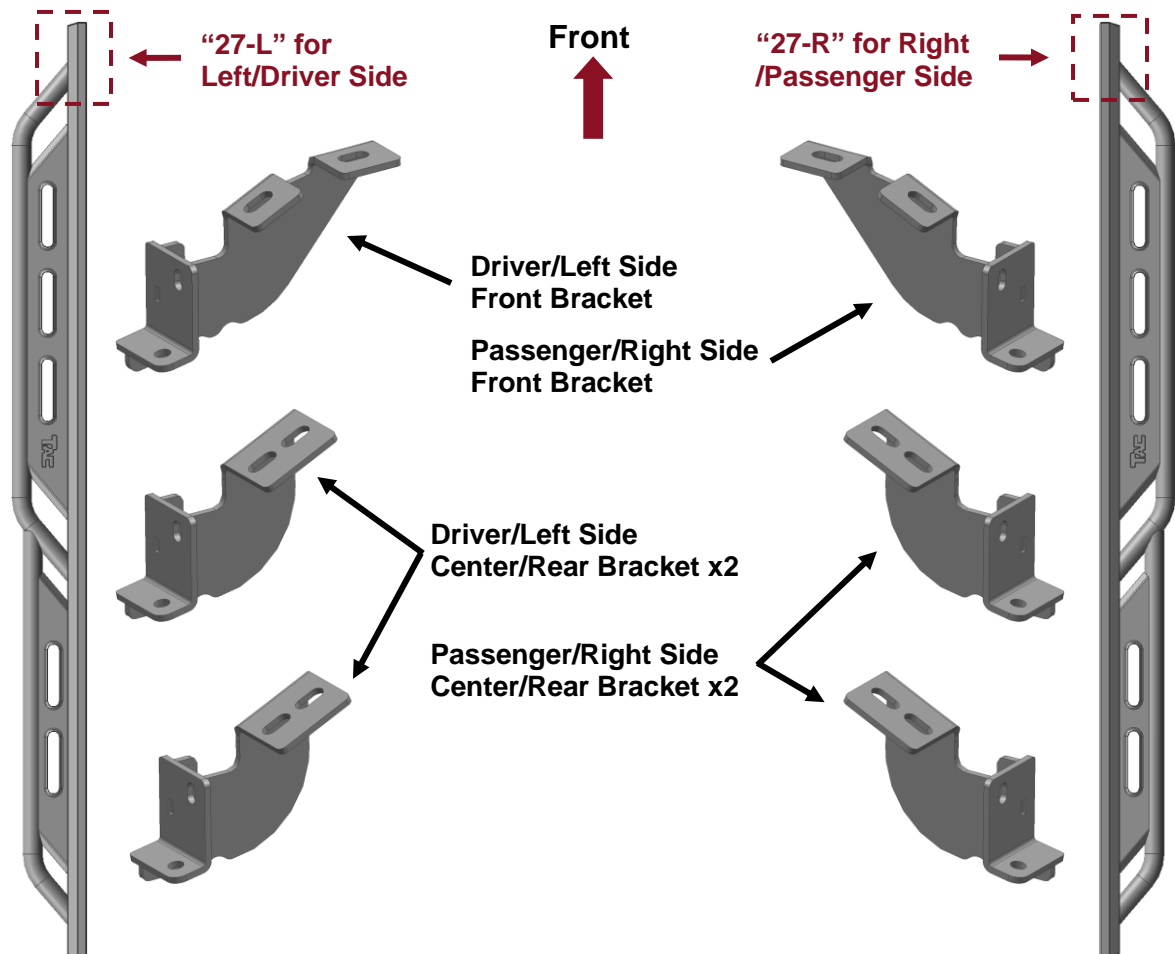



8mm x 30mm
Hex Bolt



8mm Flat Washer



8mm Lock Washer

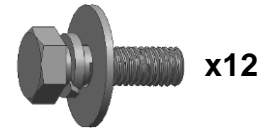

8mm x 25mm
Combo Bolt

PLEASE NOTE THAT THE FOLLOWING PICTURES ARE BASED ON THE DRIVER SIDE INSTALLATION

STEP 1

Starting on the Driver/Left front of the vehicle, remove the plastic plugs, (or hex bolts), covering the threaded holes in the body panel, **(Fig 1)**.

FIG 1

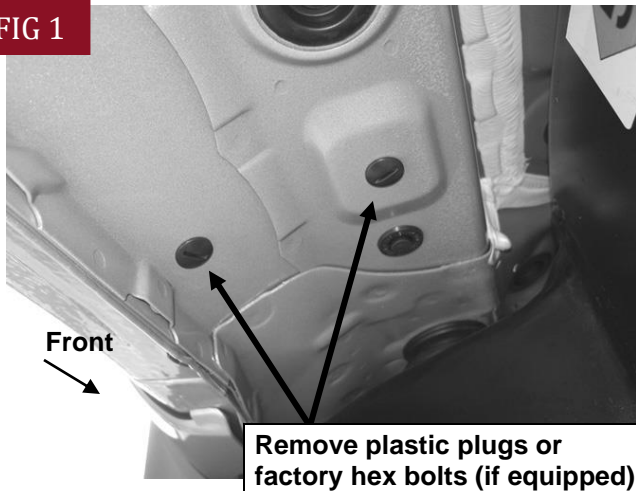

(Fig 1) Driver/Left front mounting location

STEP 2

Select the Driver/Left Front Mounting Bracket. Attach the Bracket to the vehicle with (2) 8mm Hex Bolts, (2) 8mm Lock Washers and (2) 8mm Flat Washers, **(Fig 2)**. Do not tighten hardware at this time.

FIG 2

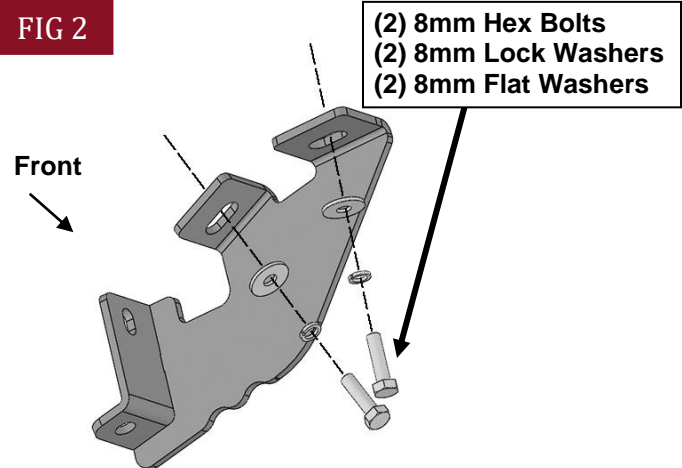

(Fig 2) Attach Driver/Left Front Mounting Bracket to the front mounting location

STEP 3

Move along the body panel to the center and rear mounting location, **(Figs 3 & 4)**. Select remaining (2) Driver/Left Center/Rear Mounting Brackets. Repeat **Step 2** to install the Mounting Bracket on center and rear mounting locations, **(Fig 5)**. Do not tighten hardware.

FIG 3



(Fig 3) Driver/Left center mounting location

FIG 4

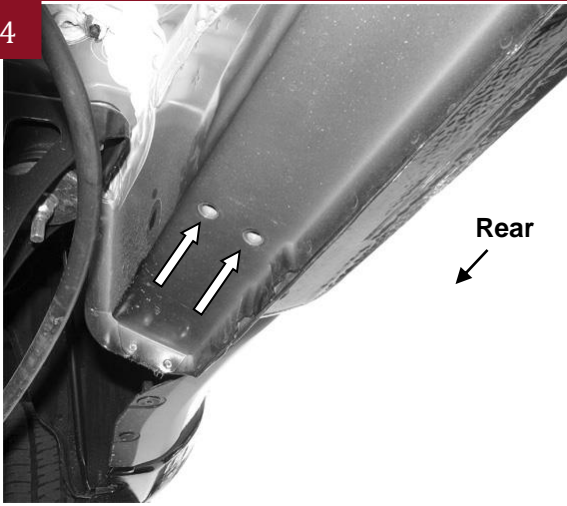

(Fig 4) Driver/Left rear mounting location

FIG 5

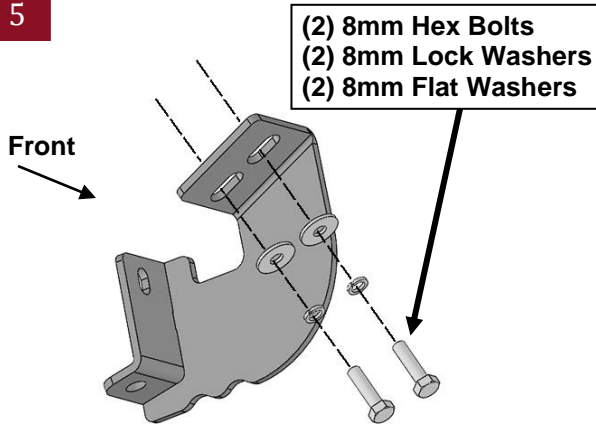

(Fig 5) Attach Driver/Left Center/Rear Mounting Brackets to the center and rear mounting locations

STEP 4

Select the Driver/Left Running Board. **NOTE:** The Driver/Left Running Board will have a “27-L” on the front. Carefully place Running Board on the brackets. **IMPORTANT:** Do not slide the Running Board front to back or damage to the finish may result. Attach Running Board to the (3) Mounting Brackets with (6) 8mm Combo Bolts, (Fig 6). Do not tighten hardware.

FIG 6

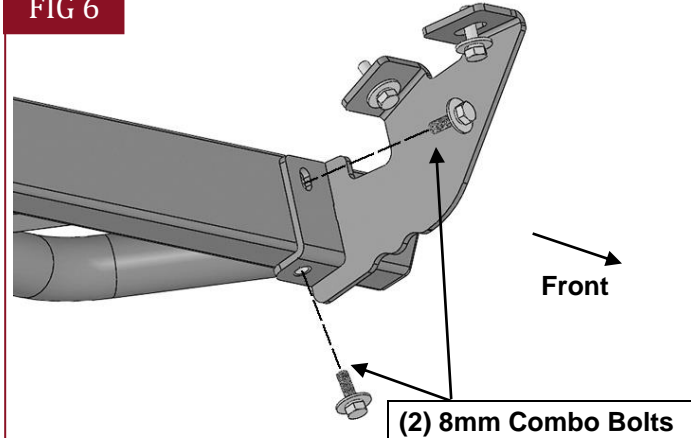

(Fig 6) Attach Driver/Left Running Board to the Mounting Brackets

STEP 5

Level and adjust the Running Board and fully tighten all hardware.

STEP 6

Repeat **Steps 1—5** to attach the Passenger/Right Running Board.

STEP 7

Do periodic inspections to the installation to make sure that all hardware is secure and tight.

Attention

To protect your investment, do not use any type of polish or wax that may contain abrasives that could damage the finish.

Mild soap may be used also to clean the Running Boards.