



ECO DROP STEP

PART #: TAC-EDS-C01

FITS: 2015-Up Chevy Colorado Crew Cab
2015-Up GMC Canyon Crew Cab



60-120 min



Cutting Not Required



Drilling Not Required

Torque & Tools

Fastener Size	Tightening Torque (ft-lbs)	Wrench Required		Allen Wrench Required	
<input type="checkbox"/> 6mm	<input type="checkbox"/> 7-8.5				
<input checked="" type="checkbox"/> 8mm	<input checked="" type="checkbox"/> 18-20		<input checked="" type="checkbox"/> 13mm		<input type="checkbox"/> 5mm
<input type="checkbox"/> 10mm	<input type="checkbox"/> 35-40		<input type="checkbox"/> 16mm		<input type="checkbox"/> 6mm
<input type="checkbox"/> 12mm	<input type="checkbox"/> 60-70		<input type="checkbox"/> 18mm		<input type="checkbox"/> 8mm

BEFORE INSTALLATION

REMOVE CONTENTS FROM BOX. VERIFY ALL PARTS ARE PRESENT. READ INSTRUCTIONS CAREFULLY BEFORE STARTING INSTALLATION. ASSISTANCE IS RECOMMENDED.

Part List

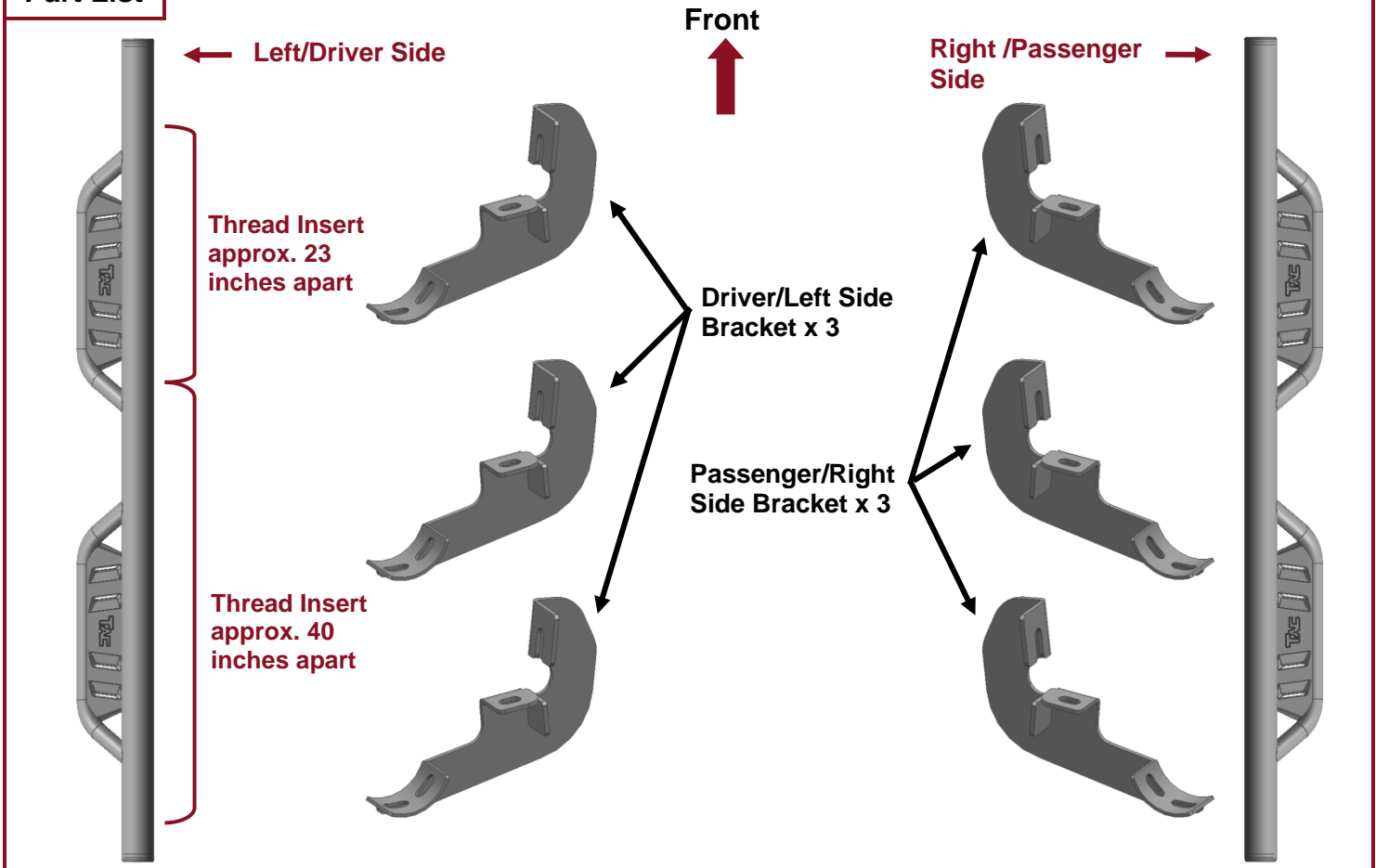



8mm x 30mm
Hex Bolt



8mm Flat
Washer



8mm Lock
Washer

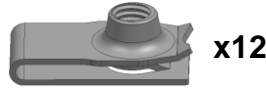

8mm Clip
Nut

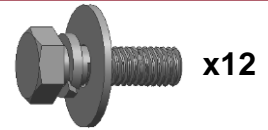

8mm x 25mm
Combo Bolt

PLEASE NOTE THAT THE FOLLOWING PICTURES ARE BASED ON THE PASSENGER SIDE INSTALLATION

STEP 1

Start the installation under the Passenger/Right side of the vehicle. Locate the front mounting location along the bottom and inner side of the body panel, (Fig 1). Installation will use the 1st, 2nd and 4th mounting locations. **NOTE:** It may help to hold a Bracket up in place to help determine the mounting holes to use along the bottom and inner side of the body.

FIG 1

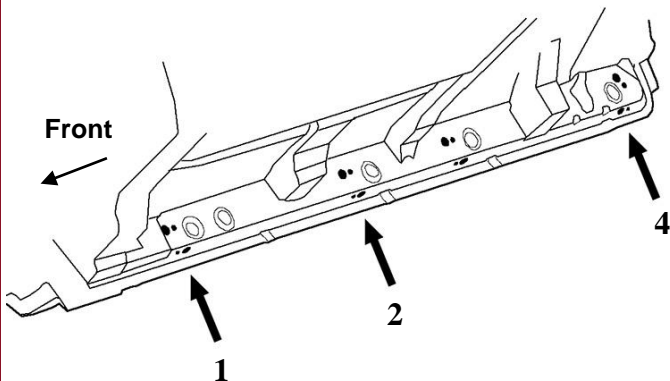

(Fig 1) Passenger side mounting locations along bottom and back of body panel illustrated

STEP 2

Remove rubber plugs as necessary from the holes in the side and bottom of the inner body panel, (Fig 2).

FIG 2

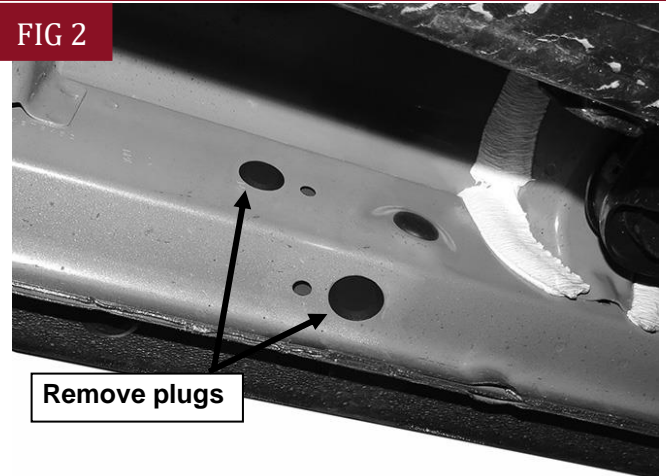

(Fig 2) Remove plugs from mounting locations as necessary

STEP 3

Select (2) 8mm Clip Nuts. Slide each Clip Nut into the large hole and over the smaller hole next to it. Line up threaded nut on the Clip Nut with smaller hole in body panel, (Fig 3)

FIG 3

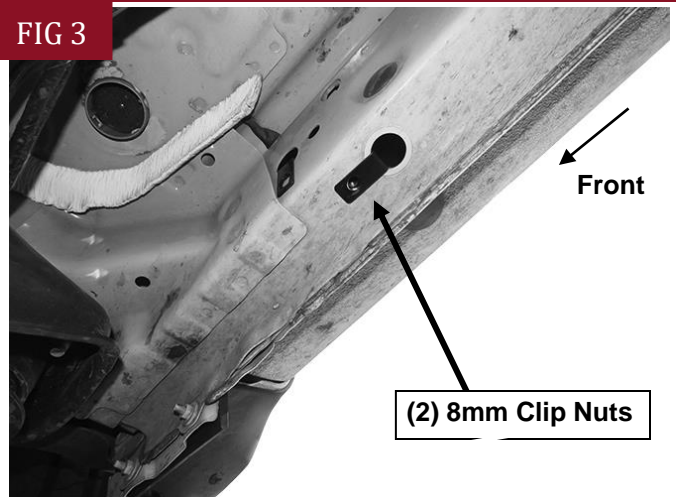

(Fig 3) Slide 8mm Clip Nut into large hole and over small hole

STEP 4

Select (1) Passenger/Right Mounting Bracket. Attach the Mounting Bracket to the (2) Clip Nuts in the vehicle with (2) 8mm Hex Bolts, (2) 8mm Lock Washers and (2) 8mm Flat Washers, (**Fig 4**). Do not tighten hardware.

FIG 4

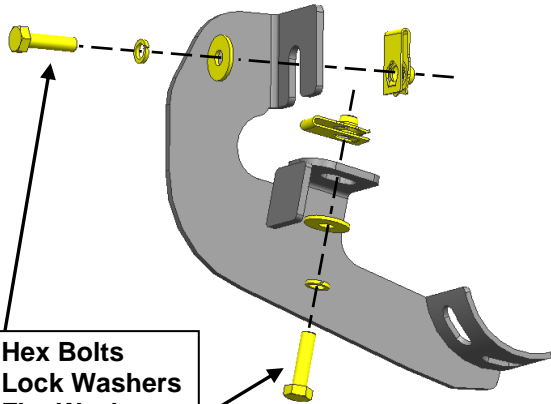

(2) 8mm Hex Bolts
(2) 8mm Lock Washers
(2) 8mm Flat Washers
(2) 8mm Clip Nuts

(Fig 4) Attach (1) Passenger/Right Mounting Bracket to the Clip Nuts

STEP 5

Repeat **Steps 1—4** to attach the remaining (2) Passenger/Right Mounting Bracket to the 2nd and rear locations, (**Figs 5 & 6**). Do not tighten hardware.

FIG 5



(Fig 5) Remove rubber plugs from the Passenger/Right center mounting location

FIG 6



(Fig 6) Remove rubber plugs from the Passenger/Right rear mounting location

STEP 6

Select the Passenger/Right Running Board. **NOTE:** Please identify the Passenger/Right Running Board according to the illustration on Part List. Carefully place Running Board on the brackets. **IMPORTANT:** Do not slide Running Board front to back on the Brackets or damage to the finish may result. Attach the Running Board to the Mounting Brackets with (6) 8mm Combo Bolts, (**Fig 7**). Do not tighten hardware.

FIG 7

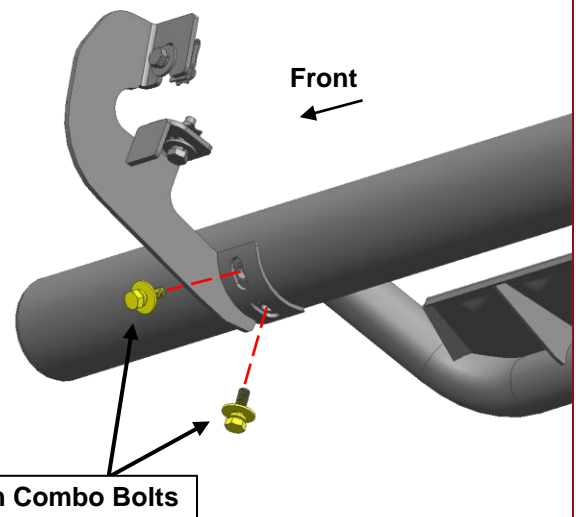

(2) 8mm Combo Bolts

(Fig 7) Attach the Passenger/Right DS7 Running Board to the Mounting Brackets

STEP 7

Level and adjust the Running Board and fully tighten all hardware.

STEP 8

Repeat **Steps 1—7** to attach the Driver/Left Running Board.

STEP 9

Do periodic inspections to the installation to make sure that all hardware is secure and tight.

Attention

To protect your investment, do not use any type of polish or wax that may contain abrasives that could damage the finish.

Mild soap may be used also to clean the Running Boards.