



INSTALLATION INSTRUCTIONS
VALUE ALUMINUM RUNNING BOARD FOR
13-19 FORD ESCAPE
PART# RB-F105B

TRUCK ACCESSORIES COMPANY

PARTS LIST:

2	Value Running Boards	2	12mm Plastic Retainers
1	Driver/Left Front Mounting Bracket	8	10mm Plastic Retainers
1	Passenger/Right Front Mounting Bracket	2	12mm x 32mm x 3mm Flat Washers
1	Driver/Left Center Mounting Bracket	2	12mm Lock Washers
1	Passenger/Right Center Mounting Bracket	2	12mm Hex Nuts
1	Driver/Left Rear Mounting Bracket	8	10mm x 27mm x 3mm Flat Washers
1	Passenger/Right Rear Mounting Bracket	8	10mm Lock Washers
2	12mm x 35mm Special Bolt Plate (rear)	8	10mm Hex Nuts
5	10mm x 35mm Button Head Bolt Plates	12	6mm T-Bolts
2	10mm x 35mm Large T-bolts (Both front outer)	12	6mm x 22mm x 2mm Flat Washers
1	10mm x 35mm Small T-bolt (Driver front inner)	12	6mm Lock Washers
		12	6mm Hex Nuts

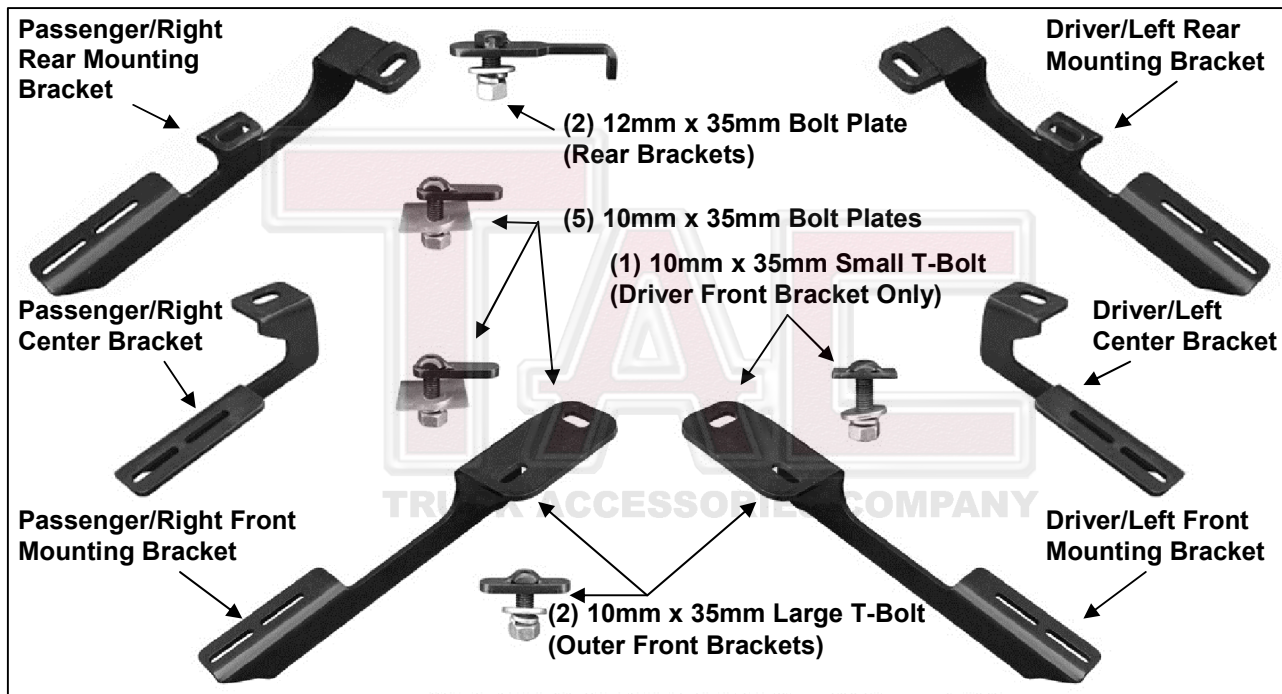

PROCEDURE:

- 1. REMOVE CONTENTS FROM BOX. VERIFY ALL PARTS ARE PRESENT. READ INSTRUCTIONS CAREFULLY BEFORE STARTING INSTALLATION. CUTTING IS REQUIRED. ASSISTANCE IS RECOMMENDED.**
- Start installation under the driver side of the vehicle. **NOTE:** To help determine the correct mounting holes to use, hold the front Bracket up in position against the floor panel and line up the Bracket with the correct holes, **(Figure 1)**.

Driver side front Bracket installation:

- Select (1) 10mm x 35mm Small T-Bolt and (1) 10mm Plastic Retainer, **(Figure 2A)**. Partially thread the Retainer onto the T-Bolt. Insert the T-Bolt into the inner factory oval hole. Rotate the T-Bolt 90-degrees so that the plate is across the slot. Thread the Retainer down until it is tight against the floor panel. The Retainer is designed to help hold the T-Bolt in place during Bracket installation.
- Next, insert (1) 10mm x 35mm Large T-Bolt with (1) Plastic Retainer into the outer oval hole in the floor panel next to the pinch weld as previously described, **(Figures 2B & 3)**.

Passenger side front Bracket installation:

- a. **IMPORTANT**-Repeat the previous **Step 2a** for passenger side Bracket installation but note that the inner mounting tab on the front Bracket will use (1) 10mm x 35mm Button Head Bolt Plate, (same bolt plate as used on center and rear Brackets), inserted into a round hole instead of the 10mm Small T-Bolt, (**Figure 2B, 4 & 5**).
3. Attach the driver side Front Bracket to the T-Bolts with (2) 10mm Flat Washers, (2) 10mm Lock Washers and (2) 10mm Hex Nuts, (**Figure 6**). Do not tighten hardware at this time.
 4. Release all the plastic clips holding the lower plastic rocker panel cover to the bottom of the body, (**Figure 7**).
 5. Measure 40" back from the bottom corner of the wheel opening to locate the correct factory hole under the plastic rocker cover for the center Bracket, (**Figure 8**). Pull plastic out to access the hole, (**Figure 10**). Partially thread (1) 10mm Plastic Retainer onto (1) 10mm x 35mm Button Head Bolt Plate, (**Figure 9**). Insert Bolt Plate, (**Figure 10**), into the round hole and thread the Retainer down tight against the body. **NOTE**: Insert the Center Bracket into the approximate position. Mark the Bracket location on the bottom edge of the plastic cover, (**Figure 11**). Cut a small slot in the bottom edge of the cover to clear the Bracket. Bolt the Bracket to the Bolt Plate with (1) 10mm Flat Washer, (1) 10mm Lock Washer and (1) 10mm Hex Nut, (**Figures 12 & 13**). Do not tighten hardware at this time.
 6. Move to the rear mounting location and remove the plastic cover on the floor panel, (**Figure 14**). Locate the small round hole under the plastic rocker cover, (**Figure 15**). Select (1) 10mm x 35mm Bolt Plate and (1) 10mm Plastic Retainer. Insert the Bolt Plate into the round hole as described in **Step 5**, (**Figures 16 & 17**).
 7. Next, locate the large round hole in the floor panel. Insert (1) 12mm x 35mm Bolt Plate into the large round hole and out the smaller hole toward the front, (**Figures 18 & 19**). Next, Slide the driver side Rear Bracket under the plastic rocker cover and over the (2) Bolt Plates, (**Figure 20**). Secure the Bracket to the outer 10mm Bolt Plate with (1) 10mm Flat Washer, (1) 10mm Lock Washer and (1) 10mm Hex Nut. Attach the Bracket to the Larger 12mm Bolt Plate with (1) 12mm Flat Washer, (1) 12mm Lock Washer and (1) 12mm Hex Nut. Do not tighten hardware at this time.
 8. Hold the plastic cover removed in **Step 6**, up in position. Trace the location of the rear Bracket onto the cover, (**Figure 21**). Carefully cut the plastic cover to clear the Bracket, (**Figures 22A & 22B**). **IMPORTANT**: Cut as little as possible from the cover. Do not cut off the mounting area for the factory hardware. Reinstall the plastic cover and all plastic clips holding the bottom of the rocker cover to the body panel.
 9. Carefully unwrap the Running Board. Slide the T-Bolts forward or back to line up with the slots in the Brackets, (**Figure 23**). Hold the Running Board up in approximate position and slide the T-Bolts down to line up with the Mounting Brackets. Tilt the Board up at a slight angle and push back against the vehicle until the T-Bolts fit into the slots on the Brackets. **VERY IMPORTANT**: The front Bracket is very close to the slots in the front-end of the Board for the T-Bolts. Loosen the Front Bracket and push it toward the rear of vehicle so that the Bracket is at a slight angle to clear the slots for the T-Bolts, (**Figure 24**). Secure the Board to the Brackets with (6) 6mm Flat Washers, (6) 6mm Lock Washers and (6) 6mm Hex Nuts, (**Figure 25**). Do not tighten hardware at this time. **NOTE**, the Running Board is designed to fit close to the vehicle. It may be necessary to loosen the Bracket hardware and tilt the Brackets downward to insert the Running Board.
 10. Level and adjust the Running Board and tighten all hardware.
 11. Repeat **Steps 2 – 10** for passenger side Running Board installation. **NOTE**: See specific passenger side front Bracket installation info in **Step 2b**.
 12. Do periodic inspections to the installation to make sure that all hardware is secure and tight.

To protect your investment, wax this product after installing. Regular waxing is recommended to add a protective layer over the finish. Do not use any type of polish or wax that may contain abrasives that could damage the finish. Mild soap may be used also to clean the Running Board.

Driver/Left Side Installation Pictured

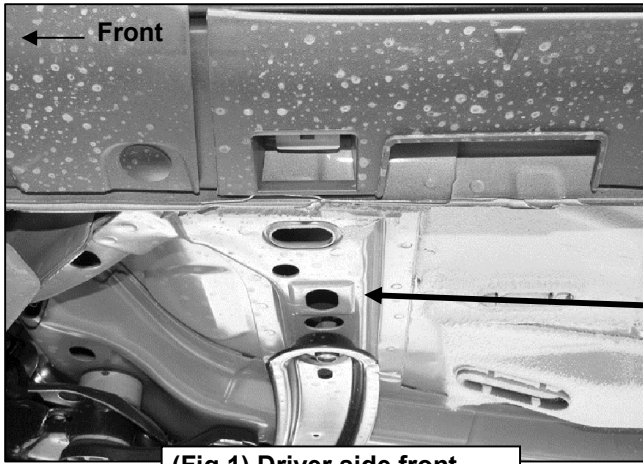

(Fig 1) Driver side front mounting location pictured

(Fig 2A) Small 10mm x 35mm T-Bolt for driver side inner front bracket only

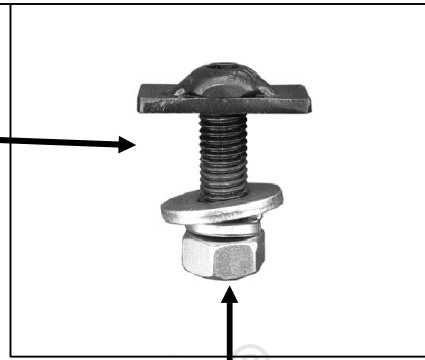

(Fig 2B) Large 10mm x 35mm T-Bolt for driver and passenger side outer location on front brackets only

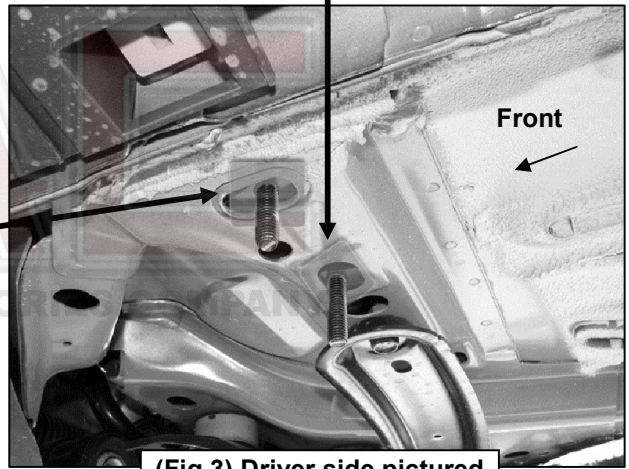
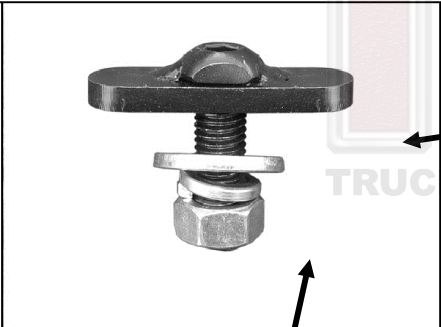

(Fig 3) Driver side pictured

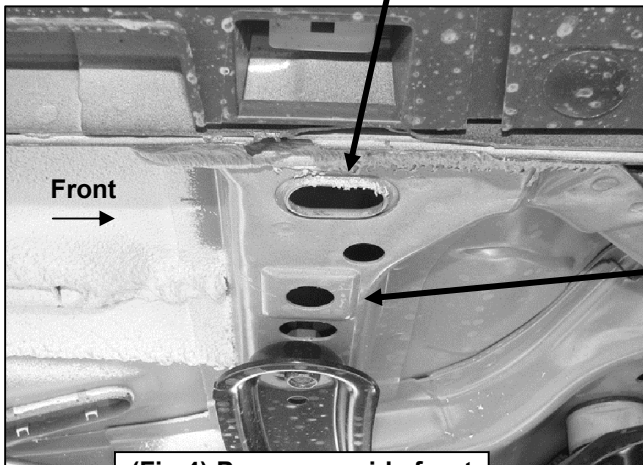

(Fig 4) Passenger side front mounting location pictured

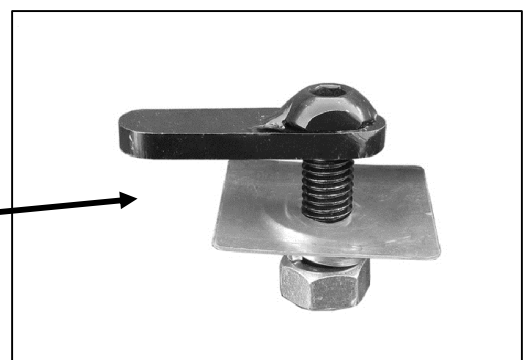

(Fig 5) Use 10mm x 35mm Bolt Plate for passenger side inner location (same bolt plate used on center and rear brackets)

Driver Side Installation Pictured

- (2) 10mm Flat Washers
- (2) 10mm Lock Washers
- (2) 10mm Hex Nuts

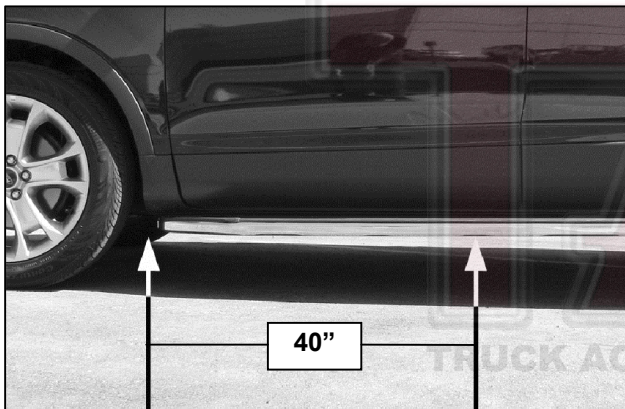
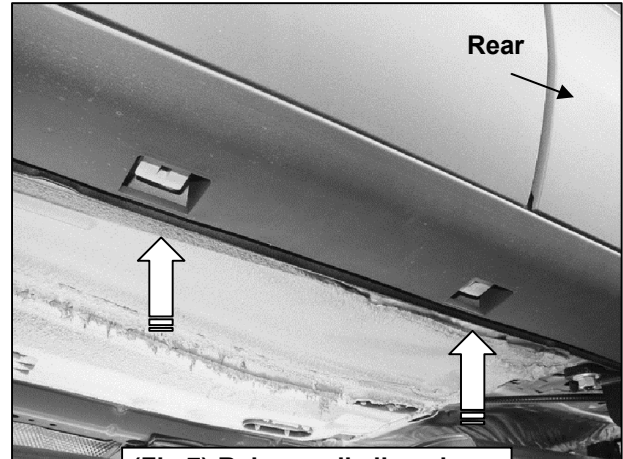
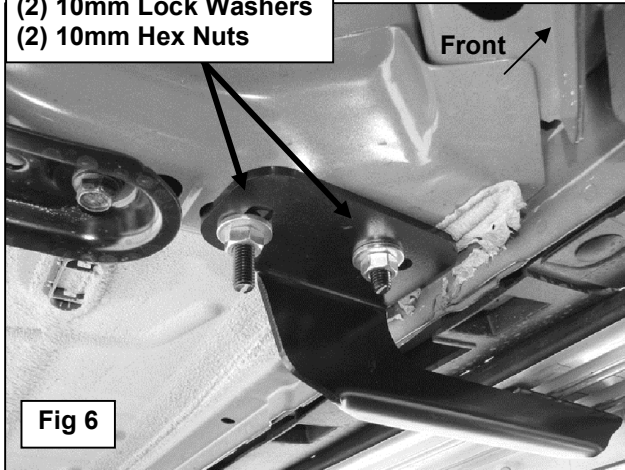

(Fig 8) Measure approximately 40" from bottom corner of wheel opening along rocker panel to locate factory hole for center bracket

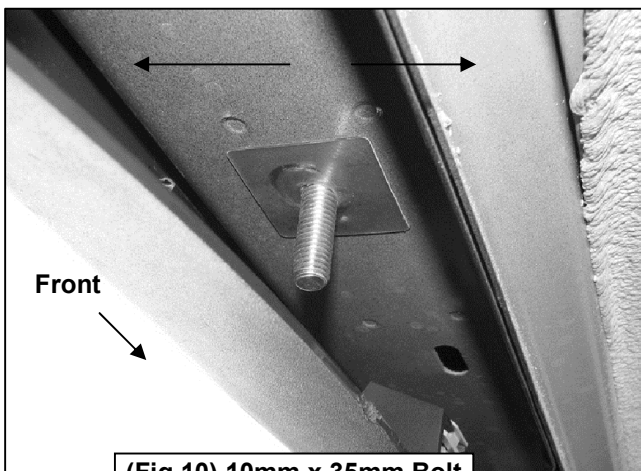
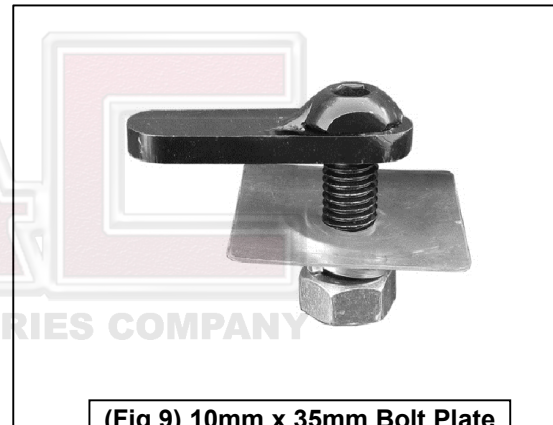

(Fig 10) 10mm x 35mm Bolt Plate with Plastic Retainer

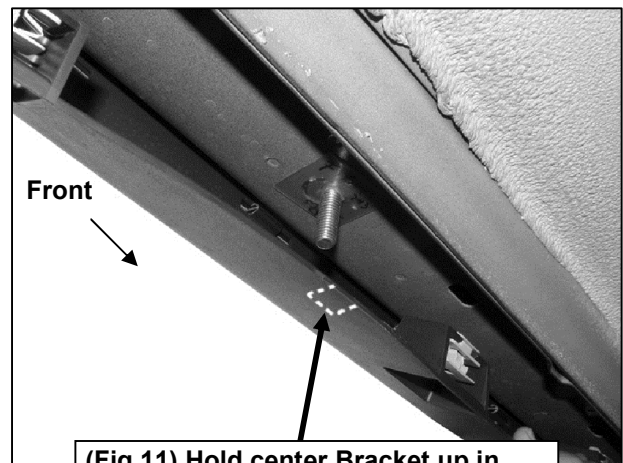

(Fig 11) Hold center Bracket up in place to determine area to cut from bottom edge of rocker panel cover

Driver Side Installation Pictured

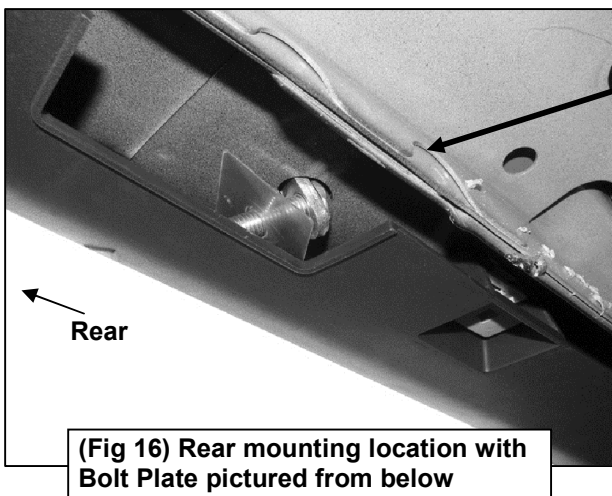
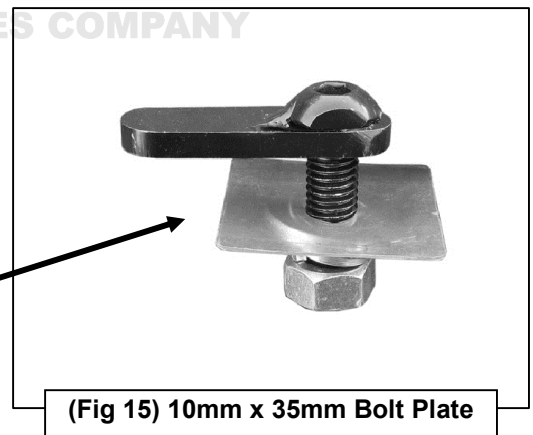
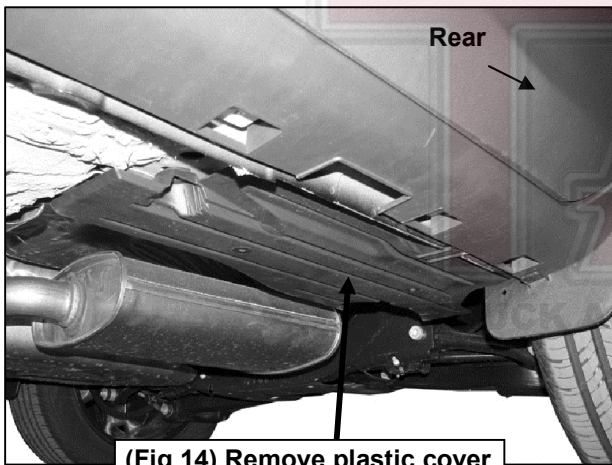
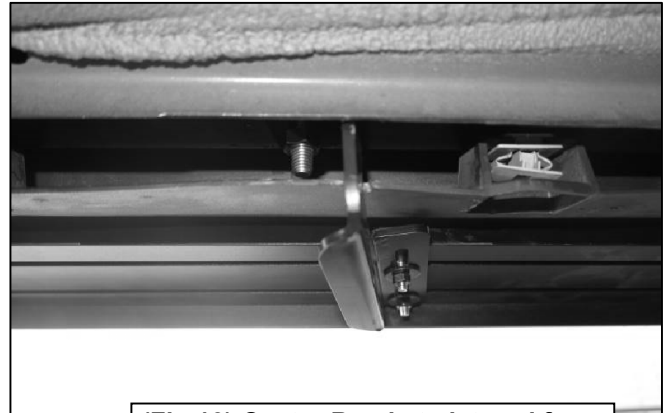
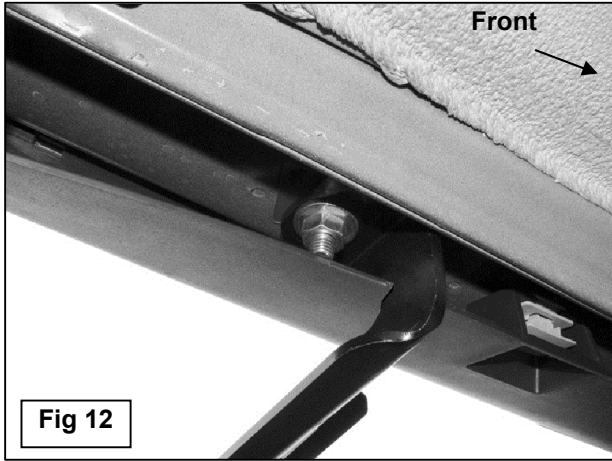

Driver Side Installation Pictured

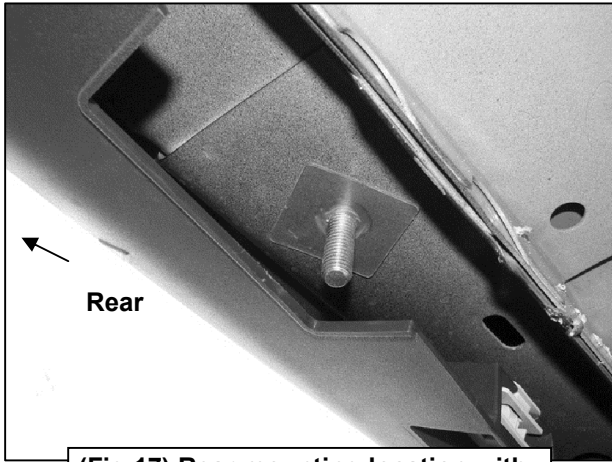

(Fig 17) Rear mounting location with Bolt Plate pictured from below

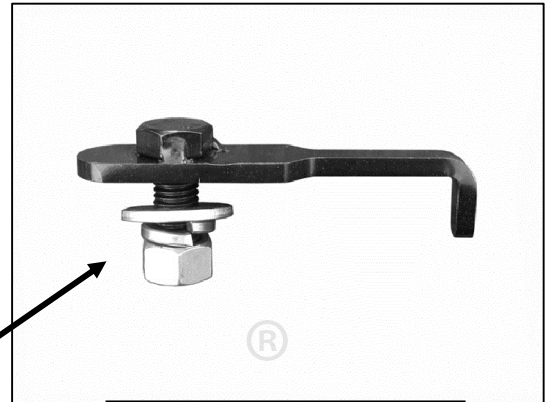

(Fig 18) 12mm x 35mm Bolt Plate for rear Bracket only



(Fig 19) Insert 12mm Bolt Plate into large hole and out smaller hole

12mm Flat Washer
12mm Lock Washer
12mm Hex Nut

10mm Flat Washer
10mm Lock Washer
10mm Hex Nut

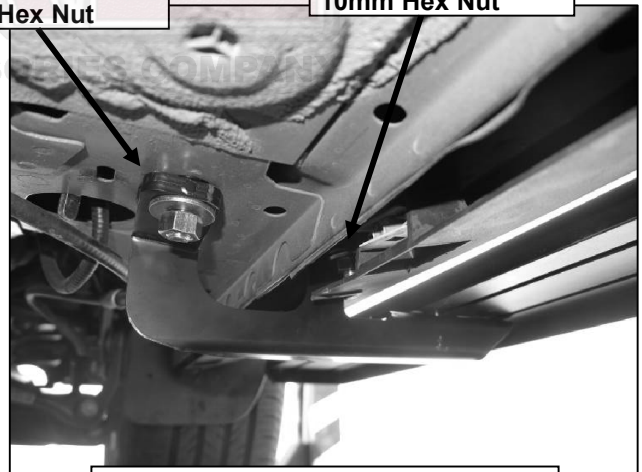

(Fig 20) Rear Bracket pictured from below with Running Board installed



(Fig 21) Hold plastic cover up in position to determine area to cut from cover

Driver Side Installation Pictured

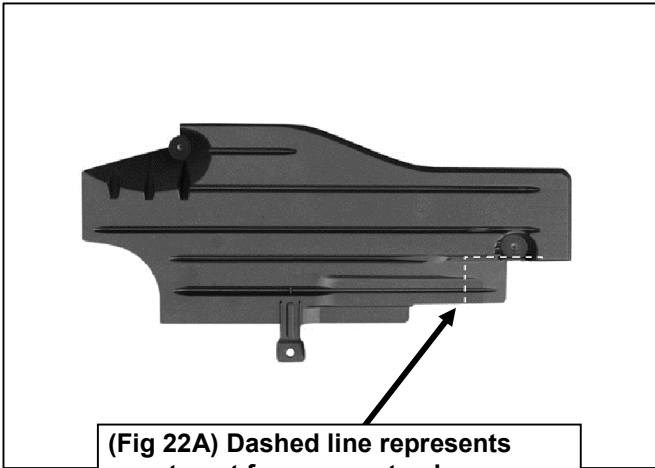

(Fig 22A) Dashed line represents area to cut from cover to clear

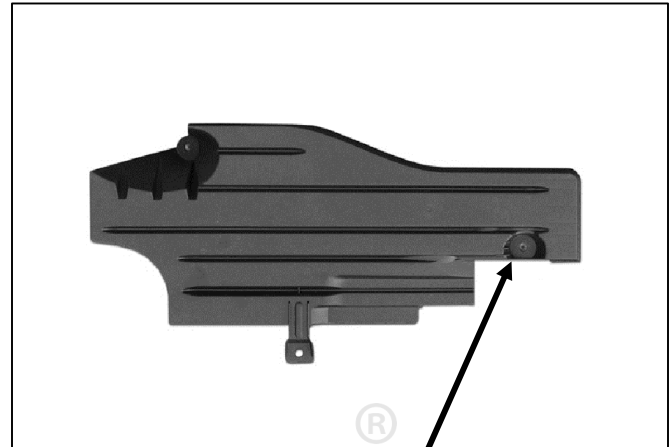

(Fig 22B) Do not cut mounting area off of cover

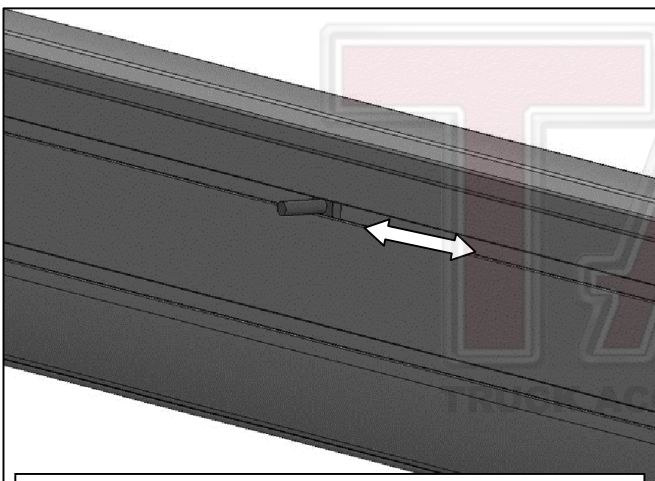

(Fig 23) Slide the T-bolts in the channels forwards or back to line up with the Bracket slots

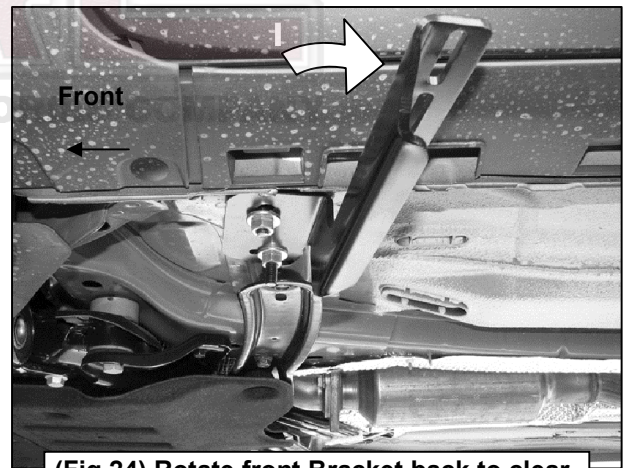

(Fig 24) Rotate front Bracket back to clear slots for T-Bolts on bottom of Board

- 6mm x 22mm Flat Washers
- 6mm Lock Washer
- 6mm Hex Nut

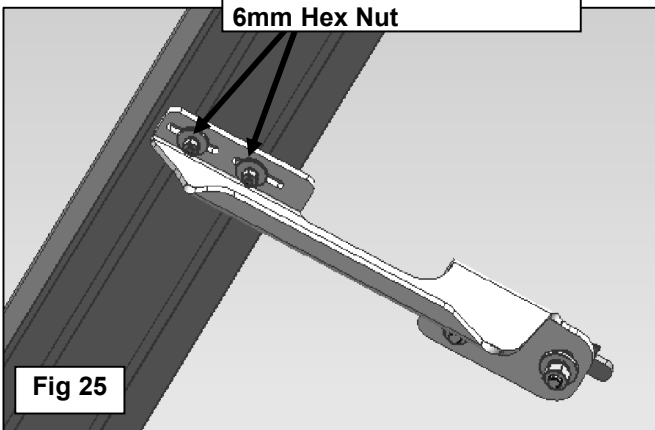

Fig 25