



## **INSTALLATION INSTRUCTIONS**

**UNIVERSAL HITCH STEP WITH NO DROP**

**EXCLUDES CLASS 1 & 2 RECEIVERS**

**ONLY FOR 2" RECEIVER HITCH**

**TRUCK PART# HT-U04**

UNIVERSAL HITCH STEP WITH NO DROP  
EXCLUDES CLASS 1 & 2 RECEIVERS  
ONLY FOR 2" RECEIVER HITCH

**PARTS LIST:**

1	Rattler Running Board (21in)	2	10mm x 27mm x 3mm Flat Washers
1	Draw Bar Welded Bracket	2	10mm Nylon Lock Nuts
1	Hitch Pin	2	6mm Double Bolt Plates
1	Hitch Pin Safety Clip	4	6mm x 22mm x 2mm Flat Washers
1	L-Shape Clamping Bracket	4	6mm Lock Washers
1	10mm U-Bolt	4	6mm Hex Nuts

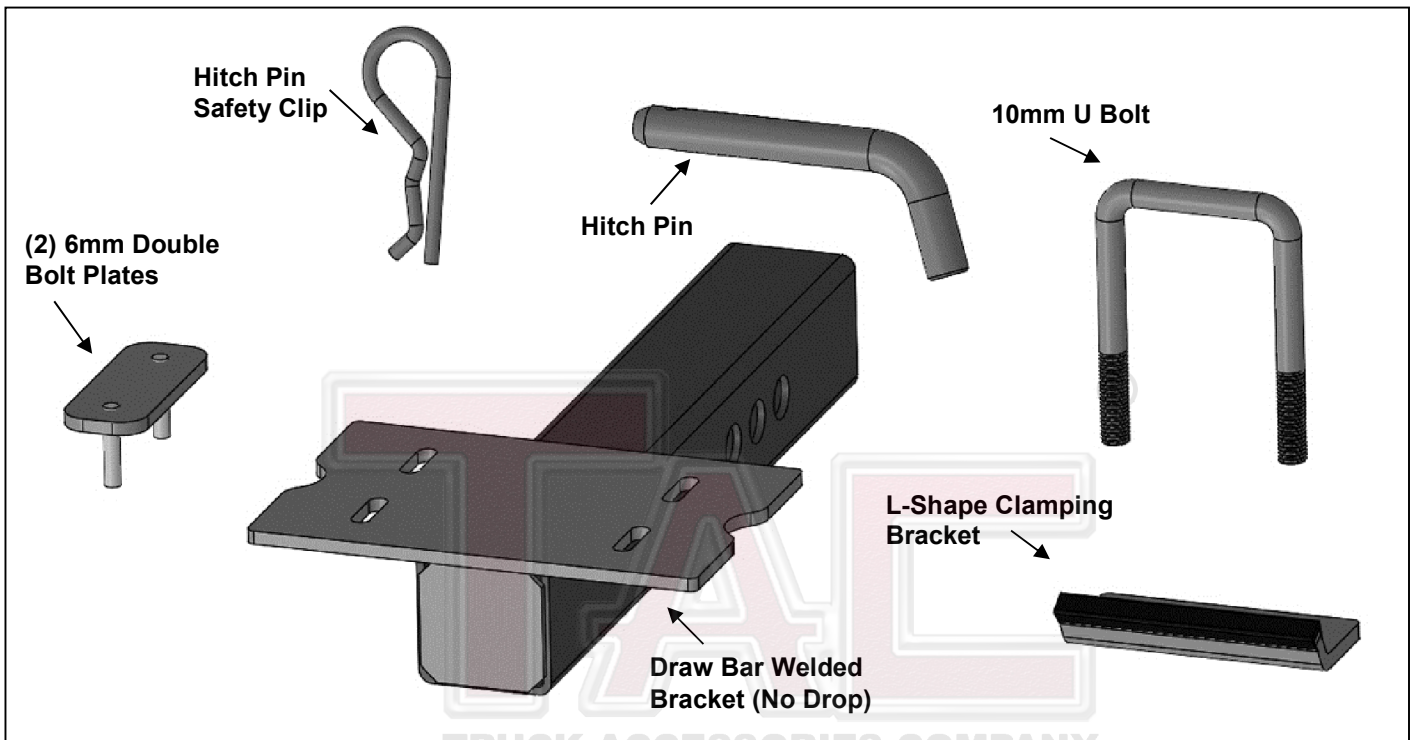

**PROCEDURE:**

**REMOVE CONTENTS FROM BOX. VERIFY ALL PARTS ARE PRESENT. READ INSTRUCTIONS CAREFULLY BEFORE STARTING INSTALLATION.**

1. Locate the tow hitch below the rear bumper, **(Figure 1)**. Next, locate the holes in the receiver hitch tube, **(Figure 2)**.
2. Select the Draw Bar Welded Bracket. Insert the Bracket into the receiver hitch tube and align the holes in the tube with the mounting holes on the Bracket, **(Figure 3)**. **NOTE:** There are 3 mounting holes available for pin adjustment.
3. Insert the Hitch Pin through the receiver tube and Draw Bar Bracket pin holes. Use the Hitch Pin Safety Clip to secure the Pin in place, **(Figure 3)**.
4. Next, select the L-Shaped Clamping Bracket and the 10mm U-Bolt. Place the L Bracket under the Draw Bar and up against the end of the receiver hitch. Insert the 10mm U-Bolt over the Draw Bar and down through the L Bracket. Use (2) 10mm Flat Washers and (2) 10mm Nylon Lock Nuts to secure the Bracket to the Draw Bar, **(Figures 4—6)**. **NOTE:** The L Bracket is used to help prevent rattling. Do not tighten hardware.
5. Select the Hitch Step Board and (2) 6mm Double Bolt Plates. Insert the Bolt Plates into the channels in the bottom of the Hitch Step, **(Figure 7)**. Raise the Step up and slide the Bolt Plates down through the slots in the Draw Bar Plate.
6. Attach the Step to the Draw Bar with (4) 6mm Flat Washers, (4) 6mm Lock Washers and (4) 6mm hex Nuts, **(Figures 8 & 9)**. Do not fully tighten hardware at this time.
7. Level and adjust the Hitch Step to the Draw Bar as necessary and fully tighten all hardware.
8. Do periodic inspections of the installation to make sure that all hardware is secure and tight.

UNIVERSAL HITCH STEP WITH NO DROP  
EXCLUDES CLASS 1 & 2 RECEIVERS  
ONLY FOR 2" RECEIVER HITCH

To protect your investment, wax this product after installing. Regular waxing is recommended to add a protective layer over the finish. Do not use any type of polish or wax that may contain abrasives that could damage the finish. Use mild soap to clean the Hitch Step.

### Rear Step Installation Pictured

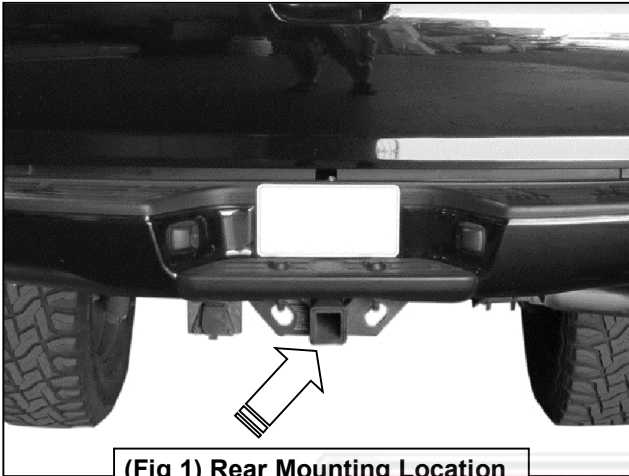

(Fig 1) Rear Mounting Location

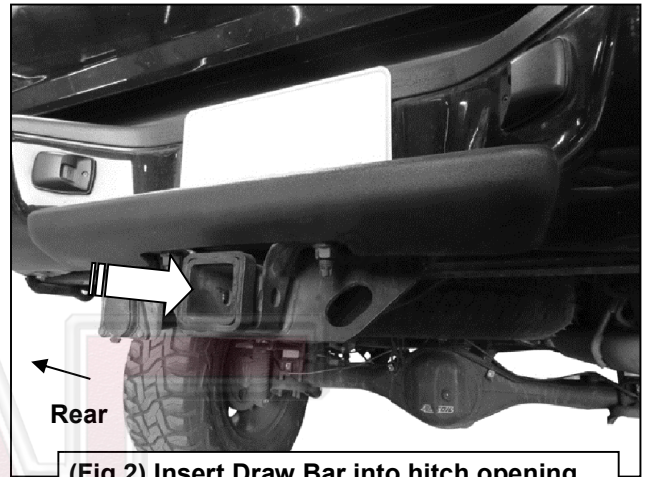

(Fig 2) Insert Draw Bar into hitch opening

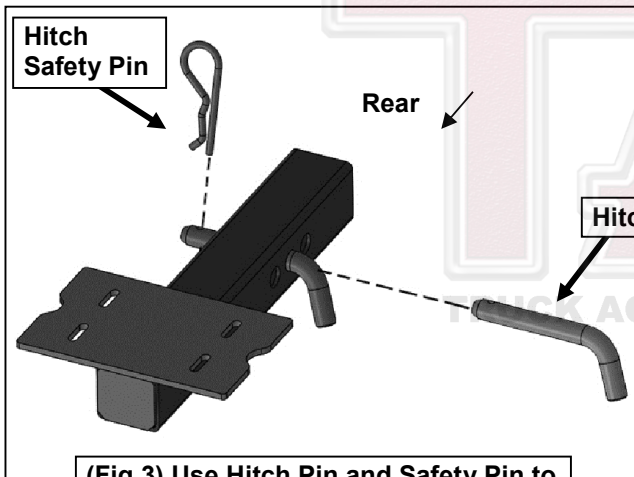

(Fig 3) Use Hitch Pin and Safety Pin to secure the Draw Bar into the hitch

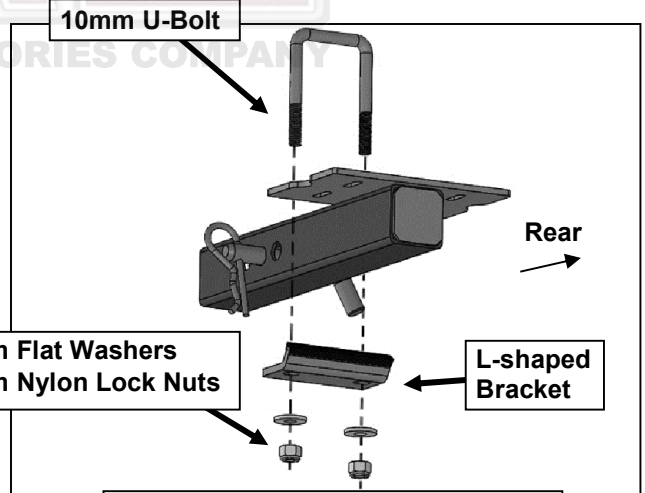

(Fig 4) Attach the L Bracket to the bottom of the Draw Bar and up against the hitch to prevent rattling

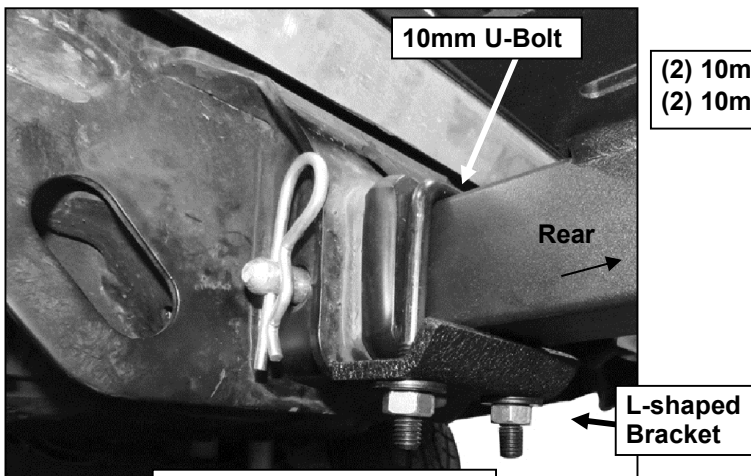

(Fig 5) L Bracket installed

UNIVERSAL HITCH STEP WITH NO DROP  
EXCLUDES CLASS 1 & 2 RECEIVERS  
ONLY FOR 2" RECEIVER HITCH

### Rear Step Installation Pictured

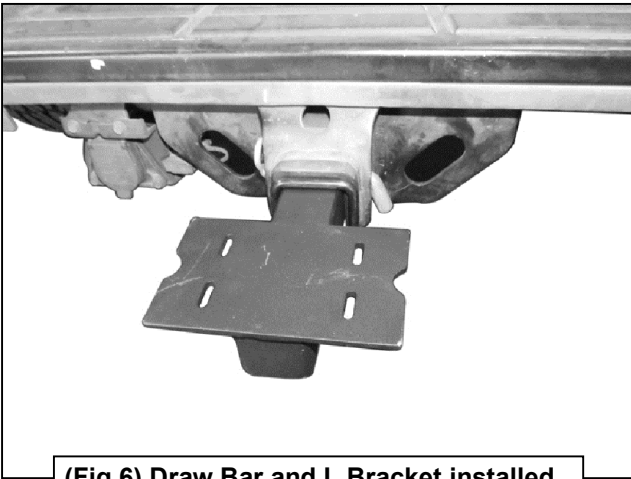

(Fig 6) Draw Bar and L Bracket installed

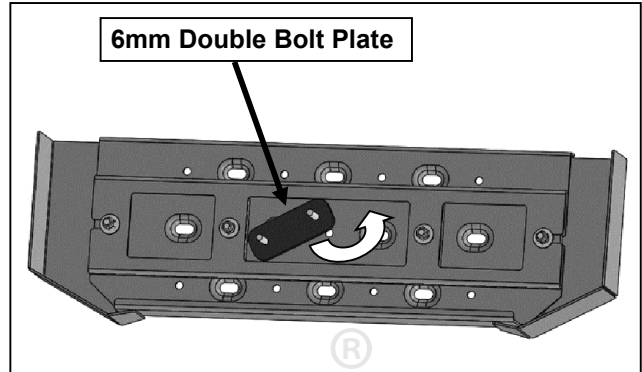

(Fig 7) Slide 6mm Double bolt plate in through the bottom of the channel on the Rattler Board

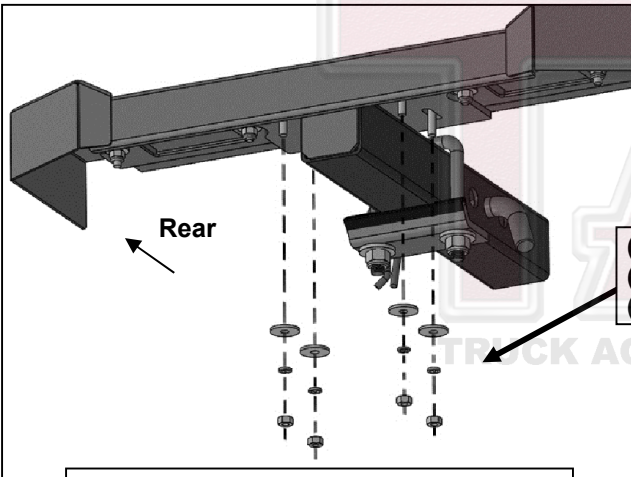

- (4) 6mm Flat Washers
- (4) 6mm Lock Washers
- (4) 6mm Hex Nuts

(Fig 8) Attach Board to Draw Bar Plate

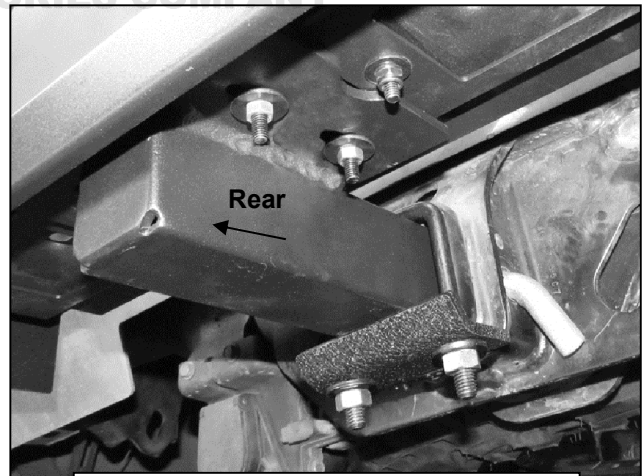

(Fig 9) Rear Step attached to Draw Bar



Complete Installation