



**INSTALLATION INSTRUCTIONS**  
**AGGRESSIVE UNIVERSAL HITCH STEP WITH 6" DROP**  
**EXCLUDES CLASS 1 & 2 RECEIVERS**  
**(ONLY FOR 2" RECEIVER HITCH)**  
**PART# HT-U02**

UNIVERSAL HITCH STEP WITH 6" DROP  
EXCLUDES CLASS 1 & 2 RECEIVERS  
ONLY FOR 2" RECEIVER HITCH

**PARTS LIST:**

1	Aggressive Hitch Step Board (26")	1	10mm x 30mm x 2mm Flat Washer
1	Draw Bar Welded Bracket, 6" Drop	1	Hitch Pin
2	8mm Double Bolt Plates	1	Hitch Pin Safety Clip
1	Anti-rattle Bracket	4	8-1.25mm Nylon Lock Nuts
1	10-1.5mm Hex Bolt with Plastic Knob	4	8mm x 24mm x 2mm Flat Washers

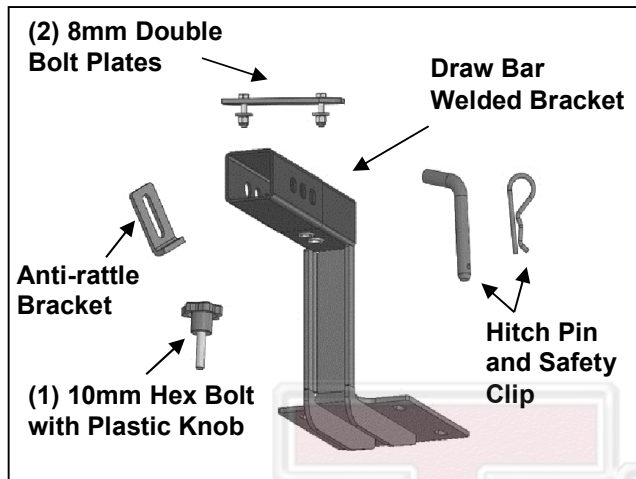

**PROCEDURE:**

**REMOVE CONTENTS FROM BOX. VERIFY ALL PARTS ARE PRESENT. READ INSTRUCTIONS CAREFULLY BEFORE STARTING INSTALLATION.**

1. Locate the tow hitch in the rear side of the vehicle for mounting location, **(Figure 1)**. Next, locate the holes in the hitch receiver tube, **(Figure 2)**. Select (1) Draw Bar Welded Bracket. Insert the Bracket into the hitch receiver tube and align the holes in the receiver tube with the mounting holes on the Bracket, **(Figures 2 & 3)**. **NOTE:** 3 mounting holes are available for pin adjustment.
2. Insert (1) Hitch Pin through the receiver tube and Bar Welded Bracket pin holes. Use (1) Hitch Pin Safety Clip to secure Hitch Pin, **(Figures 4 & 5)**.
3. Locate the (2) holes underneath the Bar Welded Bracket, **(Figure 3)**. Line up the anti-rattle Bracket with the best fit insert hole on the Bar Welded Bracket. Attach the anti-rattle Bracket to the Bar Welded Bracket using (1) 10mm Flat Washer and (1) 10mm Hex Bolt with Plastic Knob, **(Figure 6)**. **NOTE:** The cradle on the anti-rattle Bracket must be closer to the rear side of the vehicle and facing upward. Do not fully tighten hardware at this time.
4. Select the Hitch Step Board and (2) 8mm Double Bolt Plates. Insert the Bolt Plates up and into the channels in the bottom of the Hitch Step, **(Figure 7)**. Raise the Step up and slide the Bolt Plates down through the slots in the Welded Bracket.
5. Attach the Step to the Bracket with (4) 8mm Flat Washers and (4) 8mm Nylon Lock Nuts, **(Figure 8)**. Do not fully tighten hardware at this time.
6. Center and adjust the Hitch Step to the Bar Welded Bracket as necessary and fully tighten all hardware.
7. Do periodic inspections of the installation to make sure that all hardware is secure and tight.

**To protect your investment**, wax this product after installing. Regular waxing is recommended to add a protective layer over the finish. Do not use any type of polish or wax that may contain abrasives that could damage the finish. Use mild soap to clean the Hitch Step.

UNIVERSAL HITCH STEP WITH 6" DROP  
EXCLUDES CLASS 1 & 2 RECEIVERS  
ONLY FOR 2" RECEIVER HITCH

### Rear Step Installation Pictured



(Fig 1) Rear Mounting Location

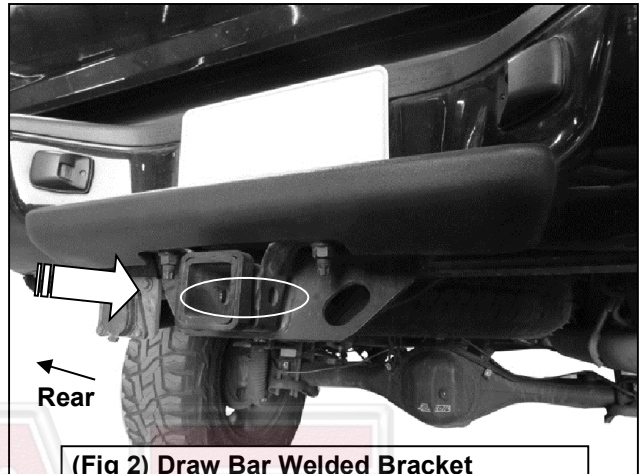

(Fig 2) Draw Bar Welded Bracket mounting location pictured

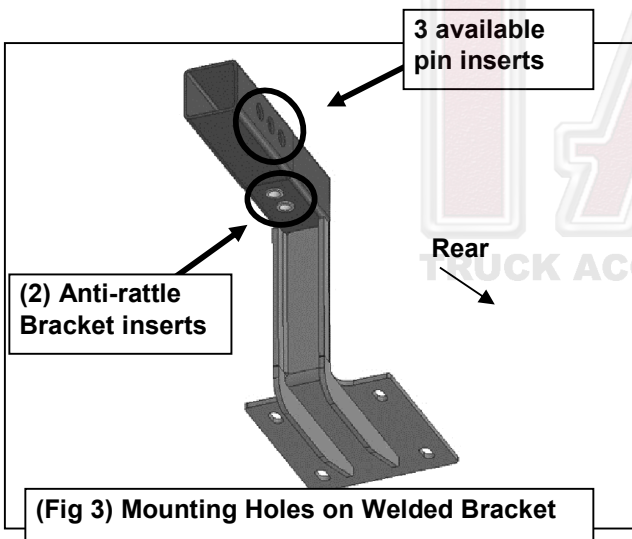

(Fig 3) Mounting Holes on Welded Bracket

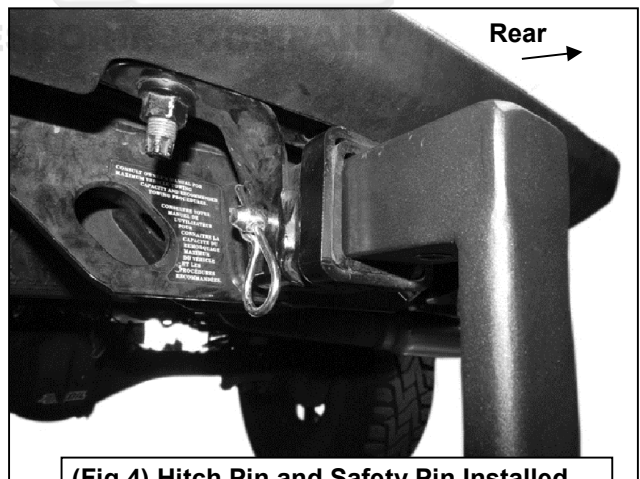

(Fig 4) Hitch Pin and Safety Pin Installed

UNIVERSAL HITCH STEP WITH 6" DROP  
EXCLUDES CLASS 1 & 2 RECEIVERS  
ONLY FOR 2" RECEIVER HITCH

### Rear Step Installation Pictured

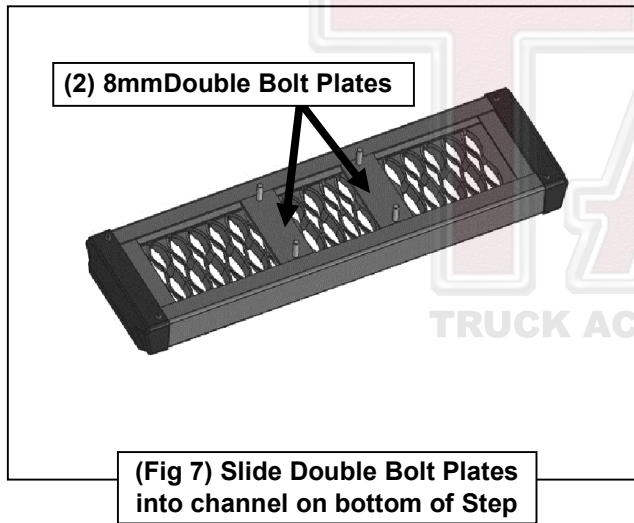
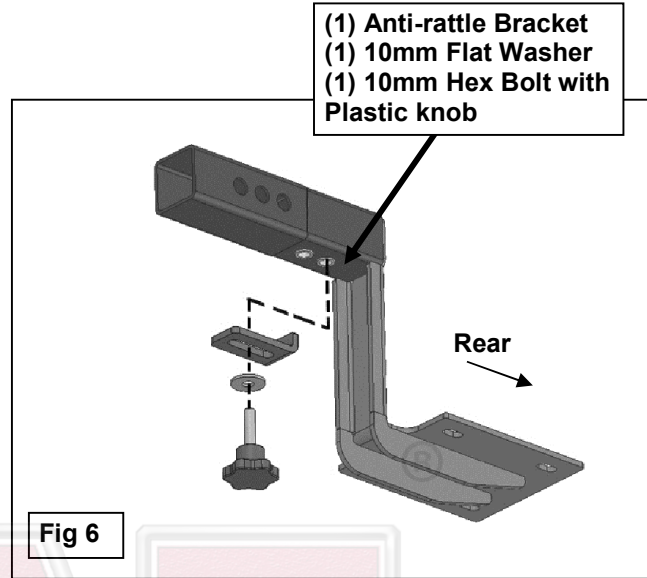
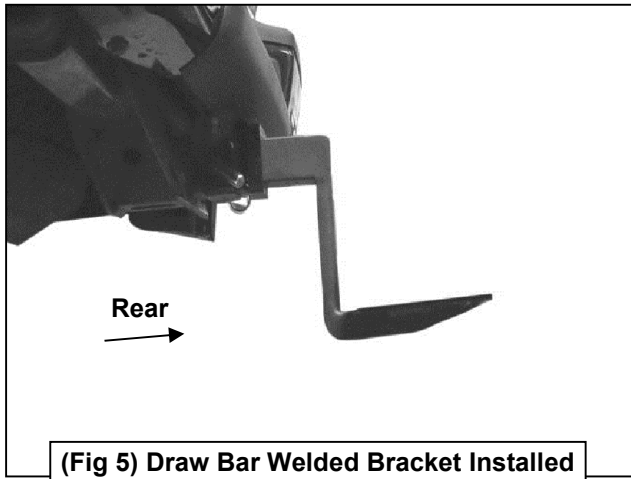

**NOTE: Make sure to center the Bar Welded Bracket to the hitch step.**

**(4) 8mm Flat Washers  
(4) 8mm Nylon Hex Nuts**

