



## **INSTALLATION INSTRUCTIONS**

**MESH EC1 MODULAR BULL BAR**

**2015-2022 CHEVY COLORADO (Excluding ZR2) / GMC CANYON**

**PART# EC1-C111TM**

**TRUCK ACCESSORIES COMPANY**

**PARTS LIST:**

1	Driver/Left Side Bull Bar Upright	12	10-1.5mm x 25mm Hex Bolts
1	Passenger/Right Side Bull Bar Upright	12	10mm x 30mm x 2.5mm Large Flat Washers
1	Top Cross Bar	16	10mm x 20mm x 2mm Flat Washers
1	Center Cross Bar	12	10mm Lock Washers
1	Driver/Left Side Bracket	8	10-1.5mm Hex Nuts
1	Passenger/Right Side Bracket	4	10-1.5mm Nylon Lock Nuts
1	Driver/Left Side Bull Bar Bracket	4	8-1.25mm x 25mm Hex Bolts
1	Passenger/Right Side Bull Bar Bracket	2	8-1.25mm x 16mm Hex Bolts
1	Mesh Fill Panel	8	8mm x 24mm x 2mm Flat Washers
2	Light Bar Brackets	4	8mm Lock Washers
1	License Plate Bracket	4	8-1.25mm Hex Nuts
2	Black Rubber Self-Adhesive Top Seal	2	6-1.0mm x 20mm Button Head Combo Bolts
2	Black Rubber Self-Adhesive Center Seal	2	6-1.0mm x 20mm Button Head Bolts
2	12-1.75mm Double Bolt Plates	4	6mm x 18mm x 1.6mm Flat Washers
4	12mm x 24mm x 2.5mm Flat Washers	2	6mm Lock Washers
4	12mm Nylon Lock Nuts	2	6mm Hex Nuts
4	10-1.5mm x 30mm Hex Bolts	1	4mm Allen Wrench

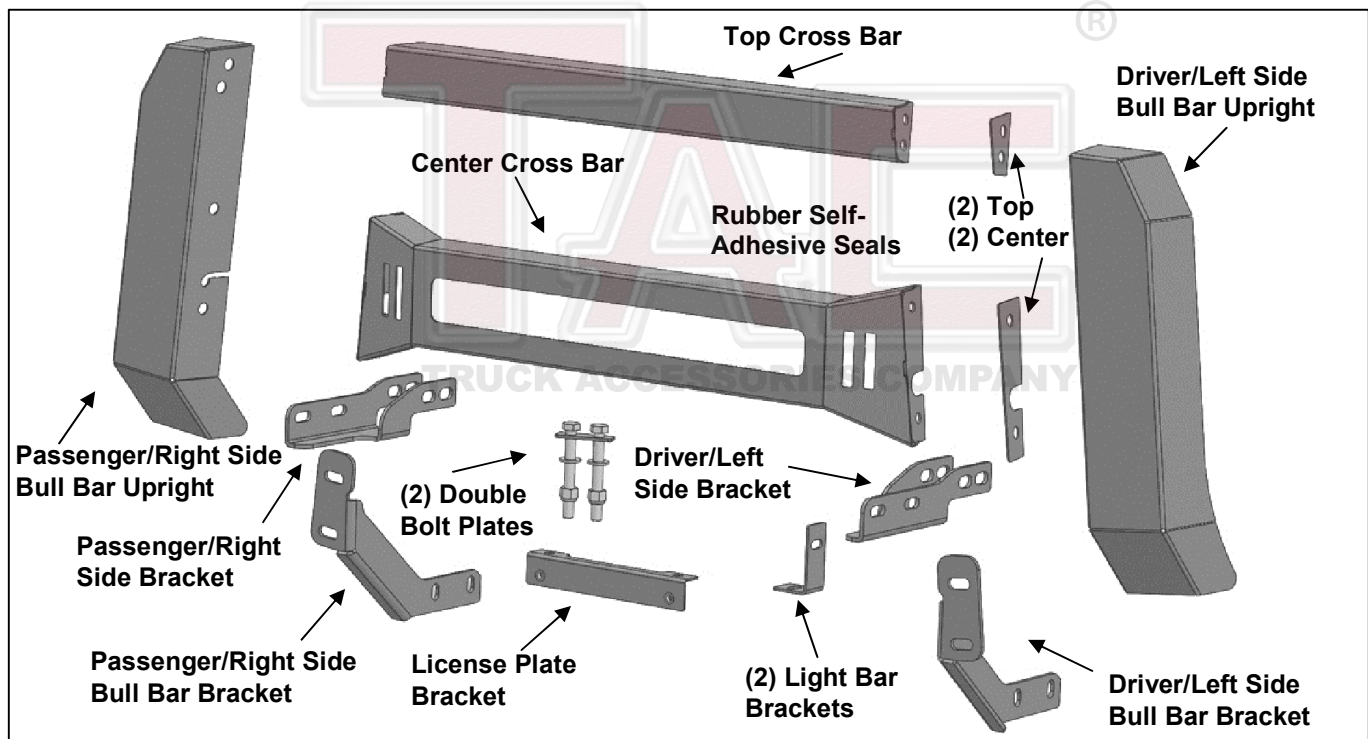

**PROCEDURE:**

**REMOVE CONTENTS FROM BOX AND VERIFY ALL PARTS ARE PRESENT. READ INSTRUCTIONS CAREFULLY. CUTTING MAY BE REQUIRED. INSTALLATION MAY INTERFERE WITH FRONT MOUNTED SENSORS.**

1. Start installation from under the front of the vehicle. Remove the plastic splash guard from below-behind bumper, **(Figure 1)**. Determine if the vehicle is equipped with tow hooks. **IMPORTANT:** Tow hooks cannot be reinstalled with the Bull Bar. Also, it may be necessary to temporarily remove the factory skid plate, (if equipped), to access the mounting locations.

**Tow Hook equipped vehicles:**

- a. Remove the driver side tow hook and hardware from the end of the frame channel, **(Figures 2 & 3)**. Also remove the seal between the opening in the bumper and the tow hook, **(Figure 4)**.
- b. Repeat to remove the passenger side tow hook and proceed to **Step 2**.

**Vehicles without tow hooks:**

- a. Cut out the indented area in both sides of the plastic bumper to clear the Brackets as pictured, **(Figures 5 & 6)**. **IMPORTANT:** Make several small cuts for best fit. **OPTION:** Cut along the rectangular cut line molded into the pocket, **(Figure 5)**, or cut around the Bracket as indicated, **(Figure 6)**.
2. Select the driver/left Frame Bracket, **(Figure 7)**. Insert the Bracket through the opening in the bumper and up to the tow hook mounting holes, **(Figures 7 & 8)**. Trim the plastic as required for Bracket clearance.
3. Line up the (2) holes in the Bracket with the (2) holes in the frame for the tow hook. Select the 12mm Double Bolt Plate, **(Figure 7)**. Insert the Bolt Plate through the Bracket and the (2) holes through the frame, **(Figures 7—10)**. Secure with (2) 12mm Flat Washers and (2) 12mm Nylon Lock Nuts. Do not fully tighten hardware at this time.
4. Select (1) driver side Bull Bar Bracket, **(Figure 7)**. Position the Bull Bar Bracket on the inside of the Mounting Bracket. Use the included (2) 10mm x 30mm Hex Bolts, (4) 10mm x 30mm Flat Washers and (2) 10mm Nylon Lock Nuts to attach the Bull Bar Bracket to the Mounting Bracket, **(Figures 7 & 11)**.
5. Repeat **Steps 2—4** to install the passenger side Brackets.
6. Select the driver side Bull Bar Upright and the Top Cross Bar. Attach the Black Rubber Self-Adhesive Top Seal between the Upright and Top Cross Bar. Bolt through the Top Cross Bar, Self-Adhesive Top Seal and Upright using (2) 10mm x 25mm Hex Bolts, (4) 10mm x 20mm Flat Washers, (2) 10mm Lock Washers and (2) 10mm Hex Nuts, **(Figure 12)**. Do not fully tighten hardware.
7. Select the Center Cross Bar. Attach the Black Rubber Self-Adhesive Center Seal between the Upright and the Center Cross bar. Bolt through the Center Cross Bar, Self-Adhesive Center Seal, and Upright with (2) 10mm x 25mm Hex Bolts, (4) 10mm x 20mm Flat Washers, (2) 10mm Lock Washers and (2) 10mm Hex Nuts, **(Figure 12)**. Do not fully tighten hardware.
8. Repeat **Step 6 & 7** to attach the passenger side Bull Bar Upright to the Top Cross Bar and Center Cross Bar. Place assembled Bull Bar face down on a clean flat surface and fully tighten top and center cross bar to upright hardware only at this time.
9. Relocation of front license plate may be necessary.
  - a. Attach the License Plate Bracket to bottom of Center Cross Bar with (2) 6mm Button Head Bolts, (4) 6mm Flat Washers, (2) 6mm Lock Washers and (2) 6mm Hex Nuts, **(Figure 13)**.
  - b. Attach license plate to Bracket with (2) 6mm Button Head Bolts, **(Figure 13)**.
10. LED light installation, (optional-light available separately).
  - a. Start at the driver/left side of the vehicle. Select (1) Light Bar Bracket. Attach the Bracket to the slot in the back of the Center Cross Bar with (1) 8mm x 25mm Hex Bolt, (2) 8mm Flat Washers, (1) 8mm Lock Washer and (1) 8mm Hex Nut, **(Figure 14)**. **NOTE:** Check for clearance between the Hex Bolt and the bottom of the Light. If necessary, insert the Hex Bolts down through the Brackets then through slots in the Cross Bar. Leave hardware loose at this time.
  - b. Repeat the previous **Step** to attach the passenger/right Light Bracket.
  - c. If needed, use the included (2) 8mm x 16mm Hex Bolts, (2) 8mm Lock Washers and (2) 8mm Flat Washers to attach the LED light bar to the Brackets, **(Figure 14)**.
  - d. Follow light manufacturer's instructions to properly wire the light bar to the electrical system.
  - e. Proceed to **Step 12**.
11. Center Screen Fill Panel Installation, (cannot be installed with LED light).
  - a. Select (1) "L" Light Bar Bracket. Attach the Bracket to the outside of the tab on the Center Screen Fill Panel with (1) 8mm x 25mm Hex Bolt, (2) 8mm Flat Washers, (1) 8mm Lock Washer and (1) 8mm Hex Nut, **(Figure 15)**. **NOTE:** Insert the Hex Bolt through the tab on the Panel and out through the Bracket. Repeat to attach the remaining Bracket to the other end of the Fill Panel. Leave hardware loose at this time.
  - b. Attach the Fill Panel with Brackets to the slots in the back of the Center Cross Bar with (2) 8mm x 25mm Hex Bolts, (4) 8mm 24mm Flat Washers, (2) 8mm Lock Washers and (2) 8mm Hex Nuts, **(Figure 15)**. **NOTE:** Insert the Hex Bolts up through the bottom of the Cross Bar and then through the Brackets.
  - c. Push the Fill Panel up tight against the inside of the opening and fully tighten hardware.
12. With assistance, hold up the assembled Bull Bar to the Bull Bar Brackets. Align the (2) holes located on the bottom of the Uprights with the (2) holes on the Bull Bar Brackets. Bolt the assembled Bull Bar to the

Brackets with (4) 10mm x 25mm Hex Bolts, (4) 10mm Lock Washers and (4) 10mm x 30mm Flat Washers, (Figure 16 & 17). Do not tighten hardware at this time.

13. Check the Bull Bar alignment with the vehicle and for clearance between the Bull Bar and the bumper. Adjust as required then fully tighten all hardware at this time.
14. Reinstall the plastic splash guard or skid plate removed in **Step 1, (Figure 1)**.
15. Do periodic inspections to the installation to make sure that all hardware is secure and tight.

**To protect your investment**, wax this product after installing. Regular waxing is recommended to add a protective layer over the finish. Do not use any type of polish or wax that may contain abrasives that could damage the finish. Mild soap may be used to clean the Bull Bar.

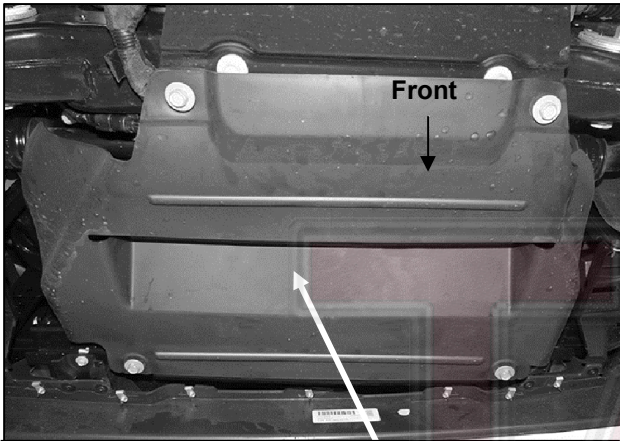

(Fig 1) Remove splash guard or skid plate from bottom of engine behind bumper if necessary

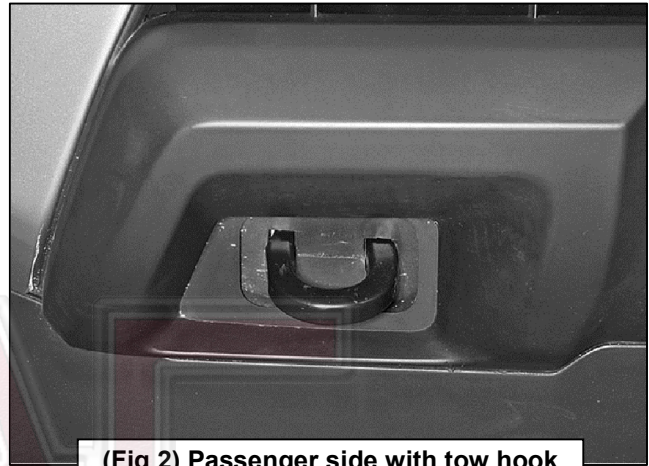

(Fig 2) Passenger side with tow hook

TRUCK ACCESSORIES COMPANY

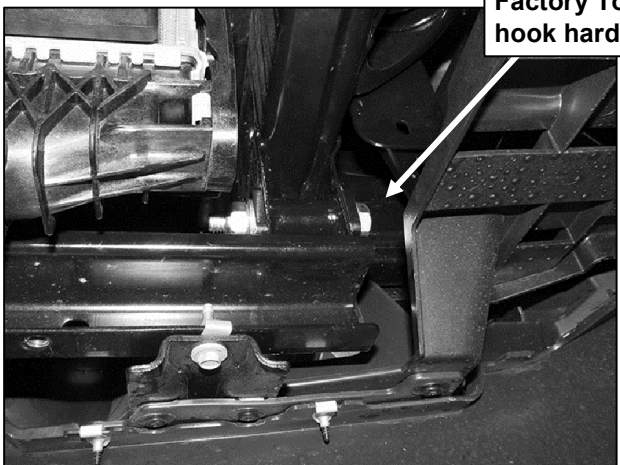

Factory Tow hook hardware

(Fig 3) Passenger side from behind bumper



(Fig 4) Driver side after tow hook removed



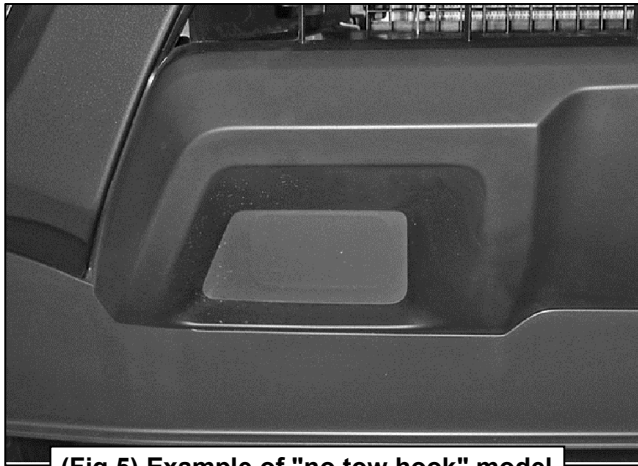

(Fig 5) Example of "no tow hook" model

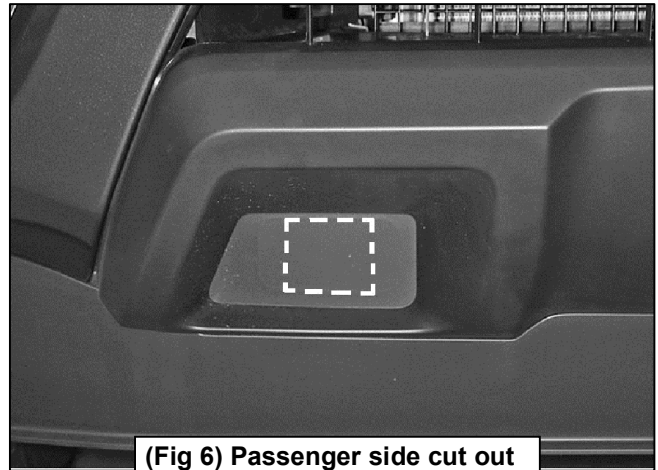

(Fig 6) Passenger side cut out illustrated for reference only

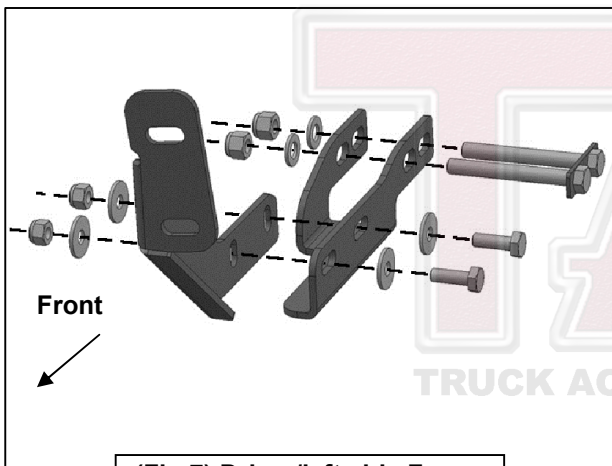

(Fig 7) Driver/left side Frame Bracket and Bull Bar Bracket

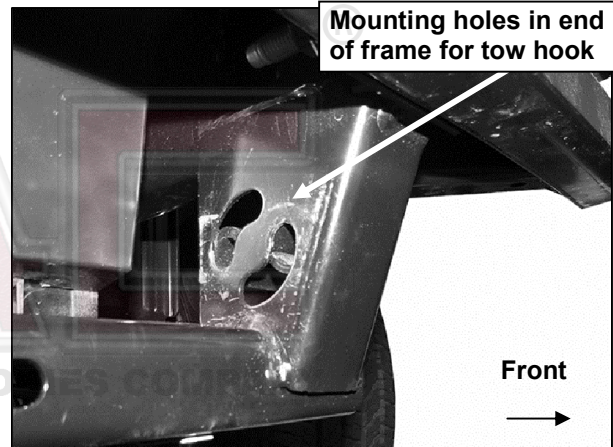

(Fig 8) Driver side pictured without bumper for instruction purposes only. Do not remove bumper

- (1) 12mm Double Bolt Plate
- (2) 12mm Flat Washers
- (2) 12mm Nylon Lock Nuts

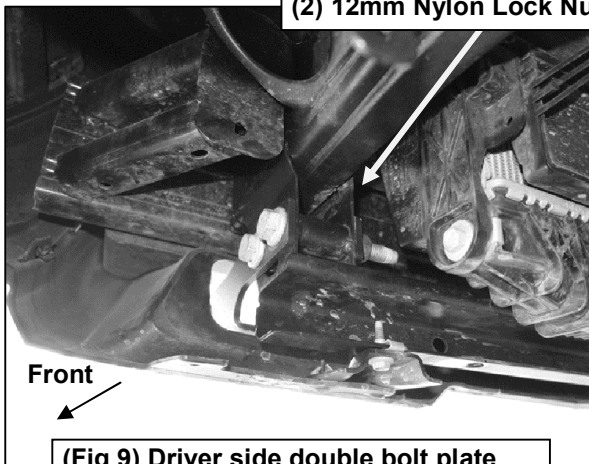

(Fig 9) Driver side double bolt plate pictured from behind bumper

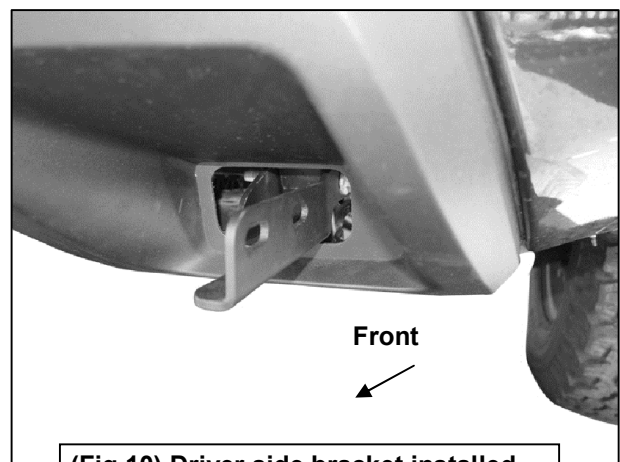

(Fig 10) Driver side bracket installed

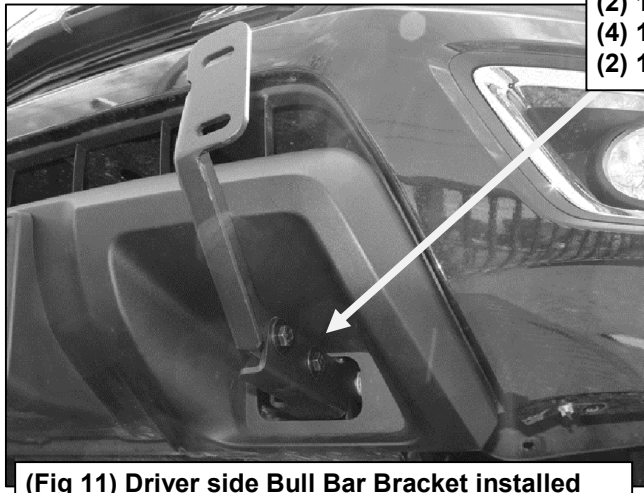

- (2) 10mm x 30mm Hex Bolts
- (4) 10mm x 30mm Flat Washers
- (2) 10mm Nylon Lock Nuts

(Fig 11) Driver side Bull Bar Bracket installed

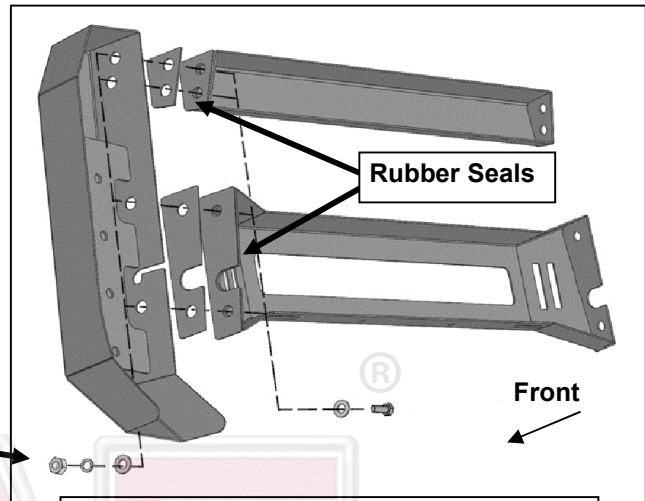

Rubber Seals

Front

- (4) 10mm x 25mm Hex Bolts
- (8) 10mm x 20mm Flat Washers
- (4) 10mm Lock Washers
- (4) 10mm Hex Nuts

(Fig 12) Driver/Left Side Bull Bar Upright attached to Top and Center Cross Bars

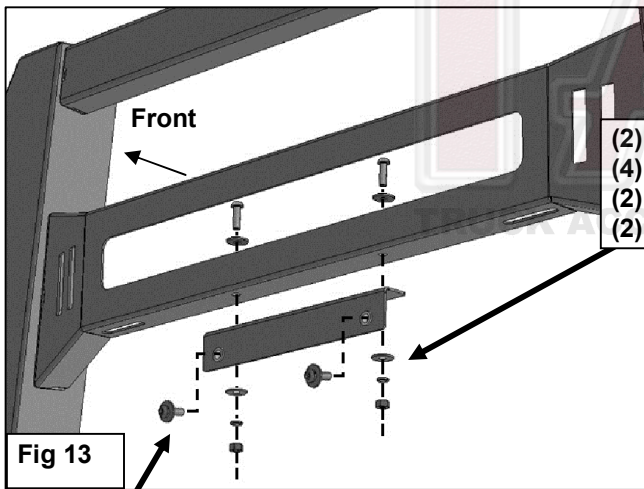

Front

- (2) 6mm Button Head Bolts
- (4) 6mm Flat Washers
- (2) 6mm Lock Washers
- (2) 6mm Hex Nuts

Fig 13

- 8mm x 25mm Hex Bolt
- (2) 8mm Flat Washers
- 8mm Lock Washer
- 8mm Hex Nuts

- (2) 6mm Button Head Combo Bolts

- 8mm x 16mm Hex Bolt
- 8mm Lock Washer
- 8mm Flat Washer

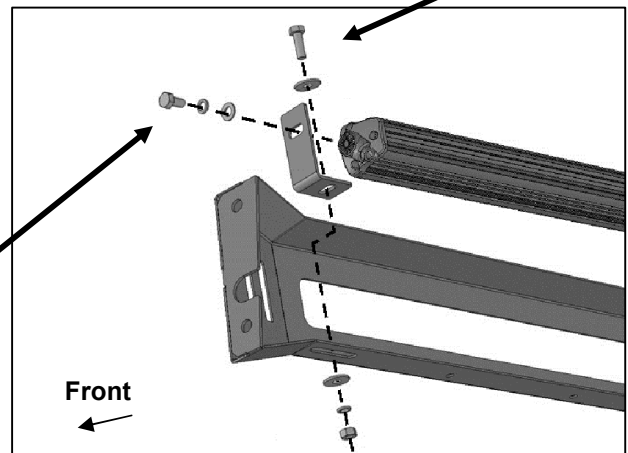

Front

(Fig 14) Attach "L" Light Brackets to slots in bottom of Center Cross Bar. Attach LED Bar light to Brackets. NOTE: Optional LED light available separately.

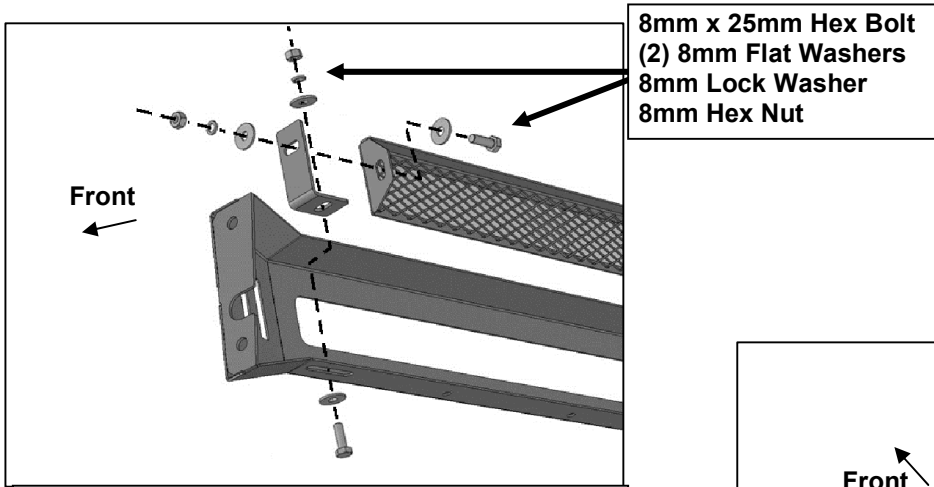

(Fig 15) Attach Center Fill Panel to "L" Brackets

