



INSTALLATION INSTRUCTIONS

**3 INCH BULL BAR
21-22 Bronco Sport
PART#71550B**

TRUCK ACCESSORIES COMPANY

PARTS LIST:

1	Bull Bar	4	10mm x 35mm Hex Bolts
1	Driver/Left Mounting Bracket	16	10mm x 27mm OD x 3mm Flat Washers
1	Passenger/Right Mounting Bracket	8	10mm Nylon Lock Nuts
4	10mm x 40mm Hex Bolts		

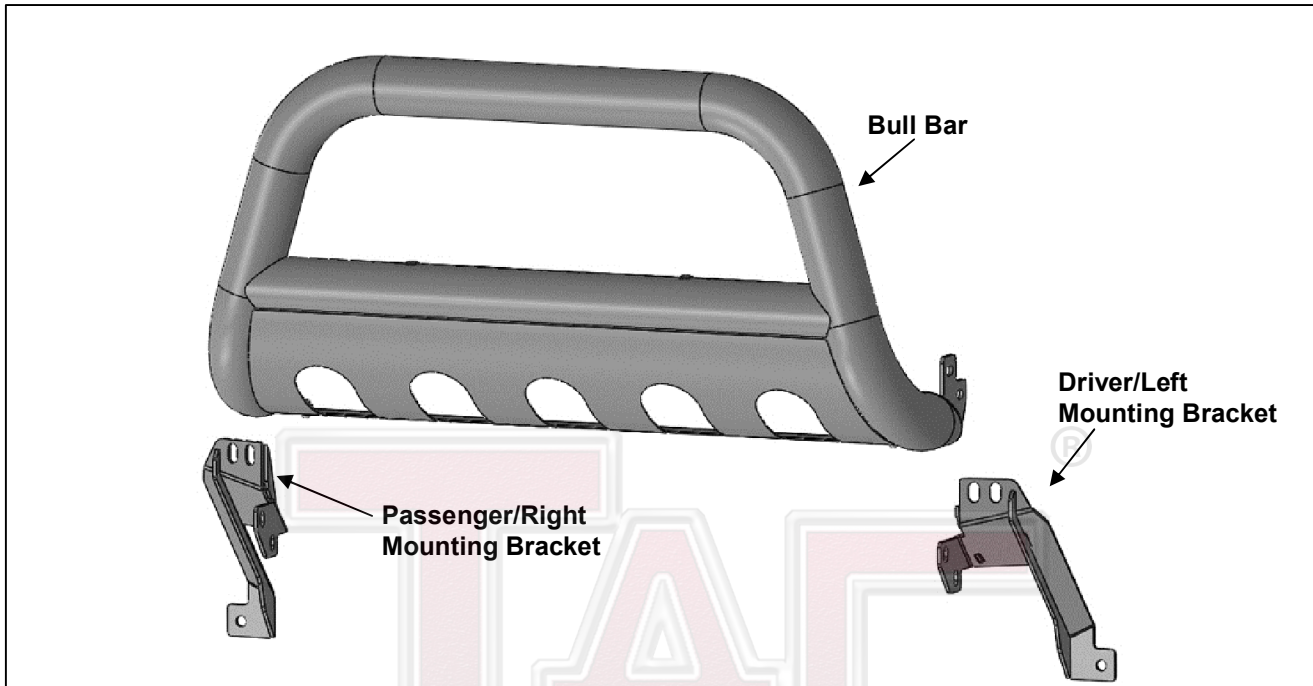

PROCEDURE:

REMOVE CONTENTS FROM BOX. VERIFY ALL PARTS ARE PRESENT. READ INSTRUCTIONS CAREFULLY BEFORE STARTING INSTALLATION. CUTTING MAY BE REQUIRED. INSTALLATION MAY INTERFERE WITH BUMPER MOUNTED PARKING SENSORS AND CAMERA. ASSISTANCE IS RECOMMENDED.

- Starting at the front of the vehicle, open the hood and remove the (8) bolts from the top of the plastic cover, **(Figure 1)**. **IMPORTANT:** On some models the plastic bumper may need to be trimmed or completely cut, **(Figures 14 & 15)**. Use a sharp knife or hacksaw blade and carefully cut out the pocket to clear the Bull Bar Brackets. Only cut enough to clear the Brackets.
- From the wheel wells, remove all the forward hardware attaching the cover to the bumper, **(Figure 3)**.
- Remove the hardware attaching the bottom of the bumper to the vehicle, **(Figure 4)**.
- From inside the wheel well, locate the (3) bolts attaching the bumper to the fender frame, **(Figure 5)**.
- Gently but firmly pull the front of the fender away from the vehicle, **(Figure 6)**.
- Remove the electrical plugs from the headlights and inside the wheel wells, **(Figures 7 & 8)**.
- With assistance, carefully remove the front bumper and headlights from the front of the vehicle, **(Figure 9)**. Place the bumper in a clean location.
- Locate the (2) outer threaded studs with flange nuts. Temporarily remove the factory nuts from the crossbar, **(Figures 10 & 11)**.
- Select the Driver/Left Mounting Bracket, **(Figure 12)**. Attach the top of the Bracket to the mounting tab with (2) 10mm Hex Bolts, (4) 10mm Flat Washers and (2) 10mm Nylon Lock Nuts, **(Figures 12 & 13)**. Reuse the factory flange nut to attach the bottom of the bracket to the threaded stud, **(Figure 13)**. Do not tighten hardware. Repeat this **Step** to attach the Passenger/Right Mounting Bracket.
- Attach the Bull Bar to the Mounting Brackets with (4) 10mm Hex Bolts, (8) 10mm Flat Washers and (4) 10mm Nylon Lock Nuts, **(Figure 16)**. Do not tighten hardware.
- Level the Bull Bar and tighten **ONLY** the mounting bracket hardware.

12. Temporarily remove the Bull Bar from the Mounting Brackets. Reattach the bumper to the vehicle only after it has been cut to clear the Brackets.
13. Reattach the Bull Bar and tighten all hardware.
14. Do periodic inspections to the installation to make sure that all hardware is secure and tight.

To protect your investment, Do not use any type of polish or wax that may contain abrasives that could damage the finish. Mild soap may be used also to clean the Bull Bar.

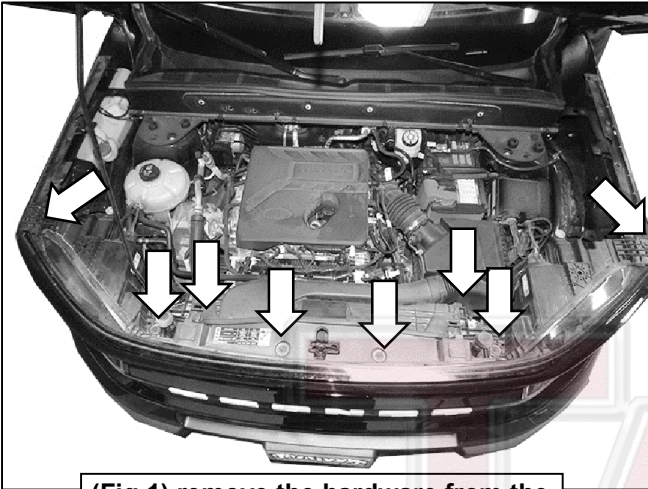

(Fig 1) remove the hardware from the top of the grille underneath the hood

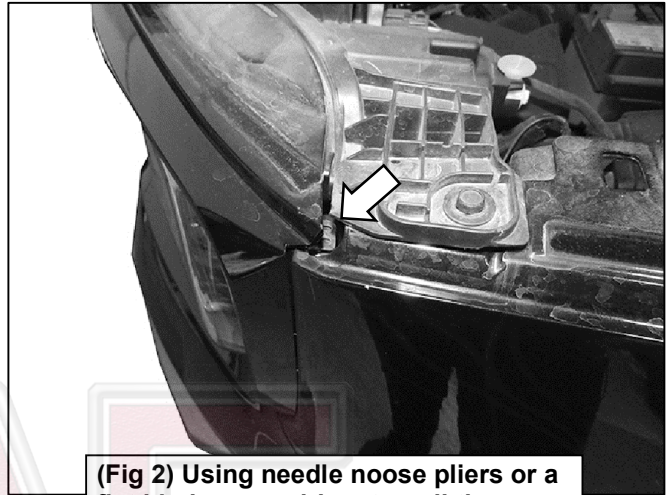

(Fig 2) Using needle nose pliers or a flat blade screwdriver to pull the headlight away from the center fascia

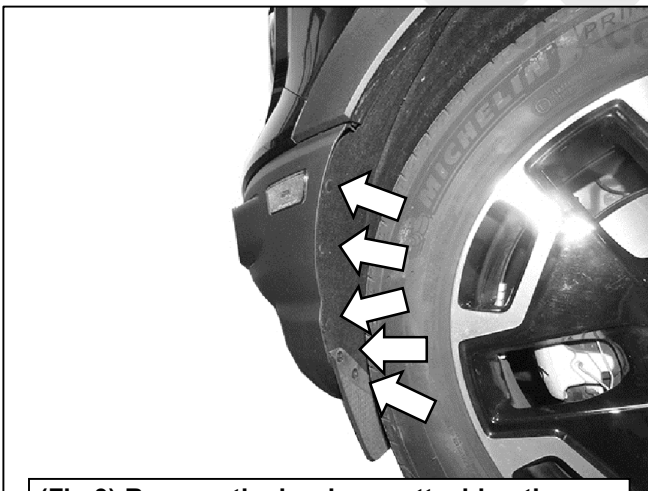

(Fig 3) Remove the hardware attaching the wheel well and mud flaps to the front bumper

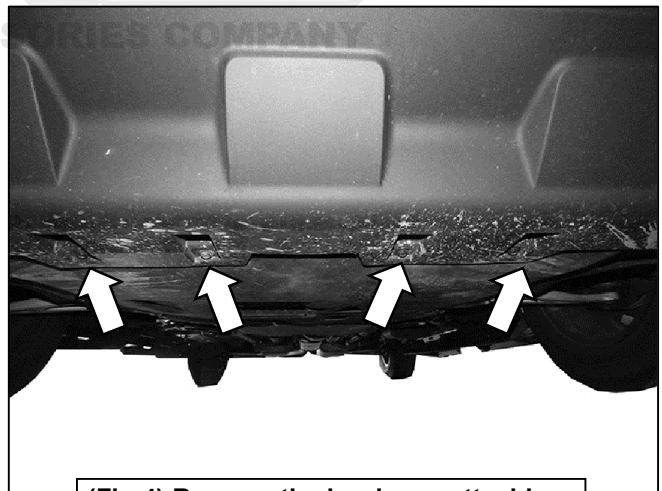

(Fig 4) Remove the hardware attaching the bottom of the bumper to the vehicle

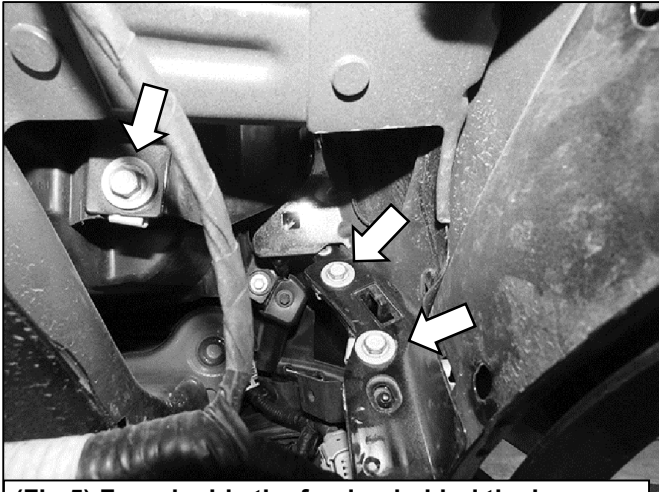

(Fig 5) From inside the fender, behind the bumper, remove hardware attaching the front bumper



(Fig 6) Gently but firmly, pull the front of the fender out from the bumper

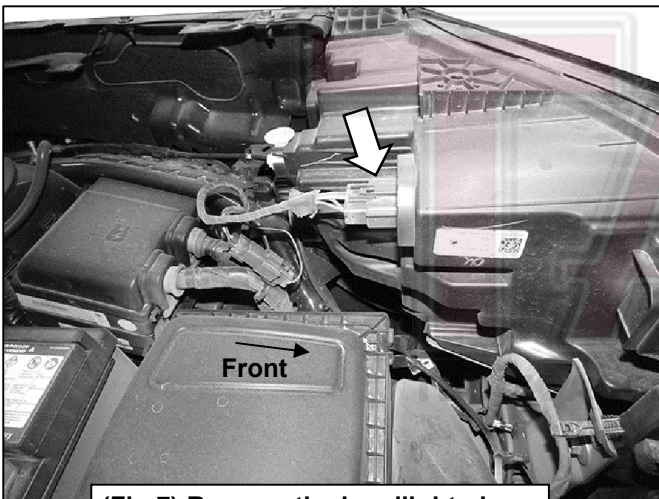

(Fig 7) Remove the headlight plugs

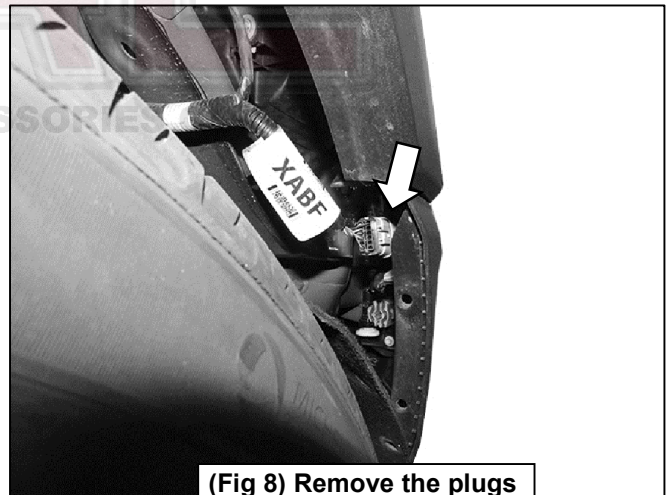

(Fig 8) Remove the plugs inside the fenders

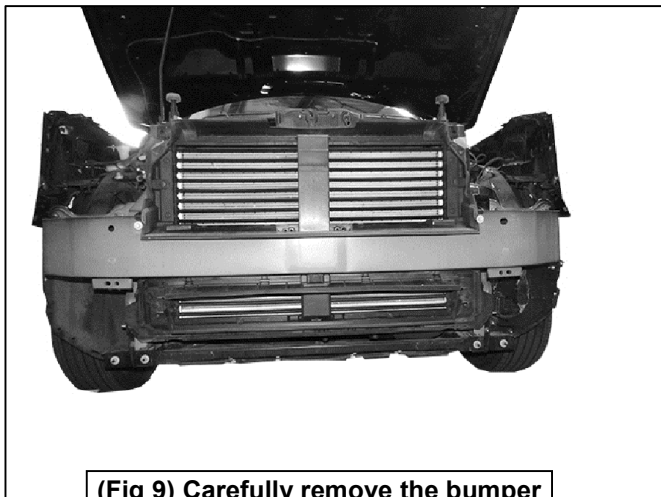

(Fig 9) Carefully remove the bumper and place in a safe location. Remove the (2) outer nuts from the lower crossbar

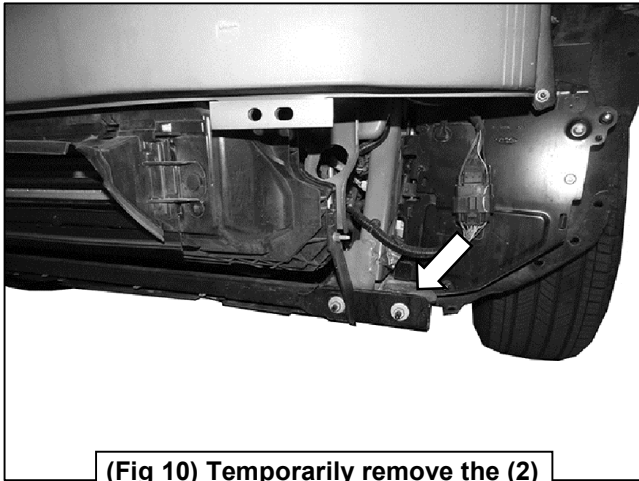

(Fig 10) Temporarily remove the (2) outer nuts from the lower crossbar

- (2) 10mm Hex Bolts
- (4) 10mm Flat Washers
- (2) 10mm Nylon Lock Nuts

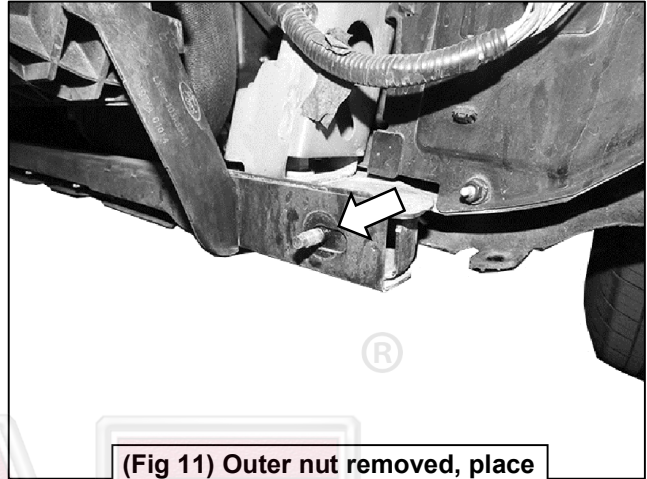

(Fig 11) Outer nut removed, place the nuts in a safe location

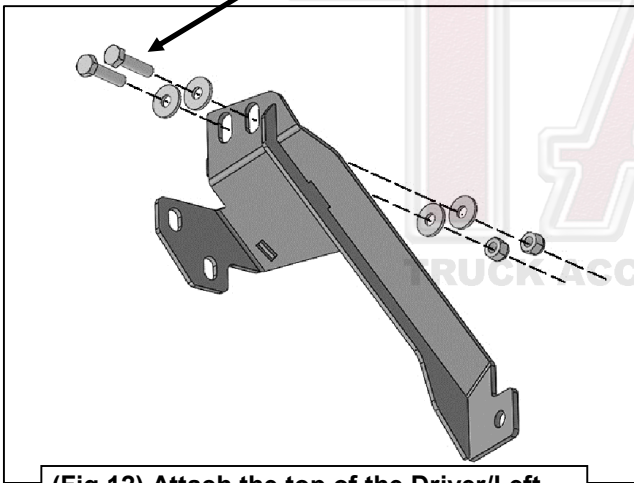

(Fig 12) Attach the top of the Driver/Left Mounting Bracket to the (2) holes in fig 10. Reuse the factory nuts to attach the bottom of the Bracket to the threaded stud

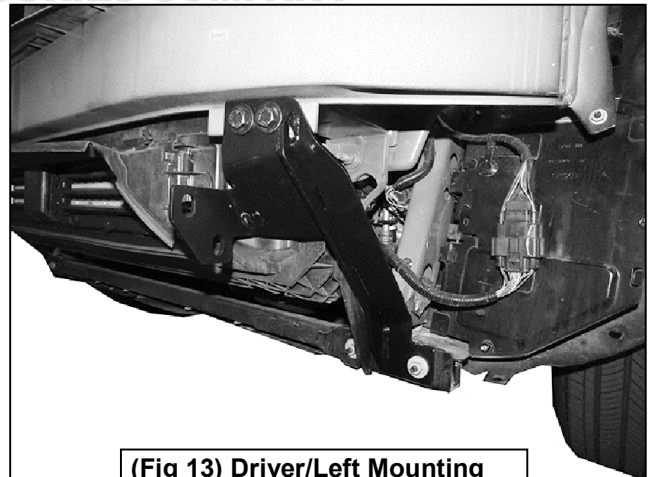

(Fig 13) Driver/Left Mounting Bracket attached to the vehicle

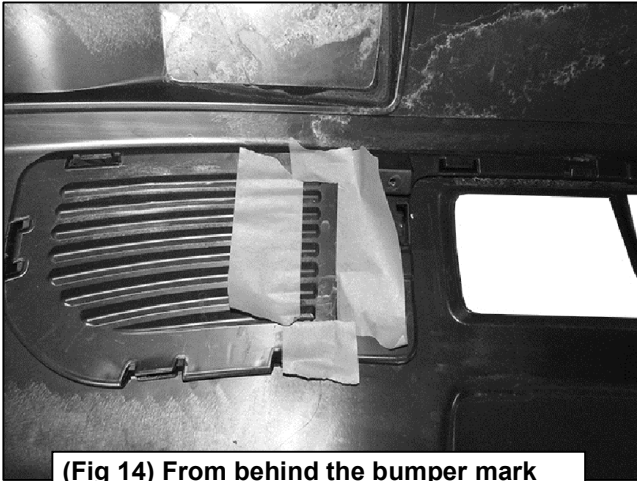

(Fig 14) From behind the bumper mark the indicated area with tape and with a hacksaw or sharp knife, make small cuts

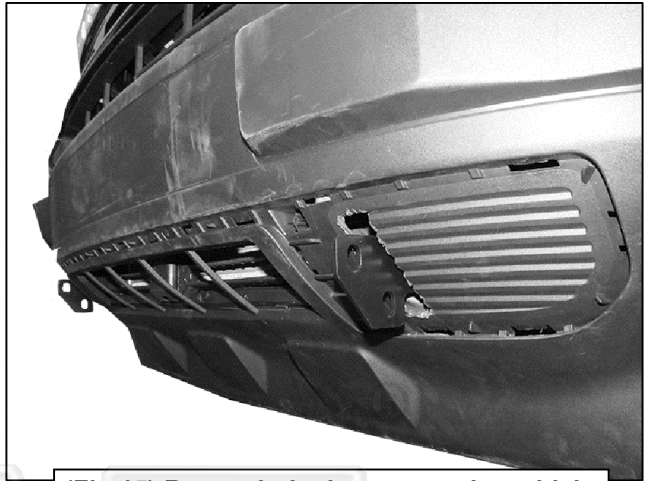

(Fig 15) Reattach the bumper to the vehicle

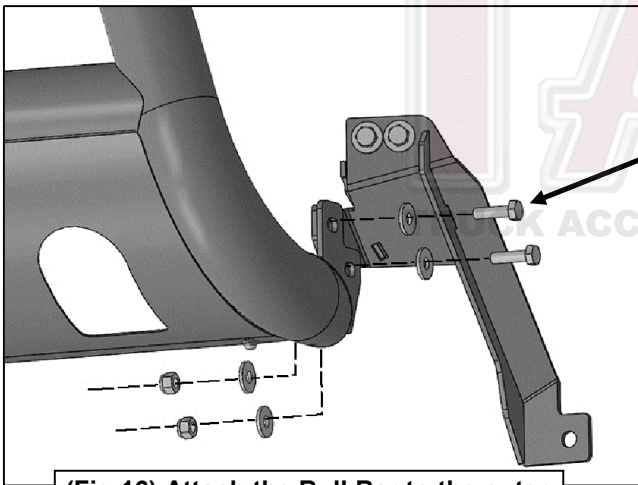

- (2) 10mm Hex Bolts
- (4) 10mm Flat Washers
- (2) 10mm Nylon Lock Nuts

(Fig 16) Attach the Bull Bar to the outer faces of the Mounting Brackets