



# **INSTALLATION INSTRUCTIONS**

**SIDE BAR**

**06-12 TOYOTA RAV4**

**PART# 232800**

**PARTS LIST:**

1	Driver Sidebar	2	12-1.75mm x 90mm Bolt Plates
1	Passenger Sidebar	2	12-1.75mm x 50mm Bolt Plates
1	Driver Front Bracket	4	12mm Hex Nuts
1	Passenger Front Bracket	4	12mm Lock Washers
1	Driver Rear Bracket	4	12mm ID x 30mm OD x 3mm Flat Washers
1	Passenger Rear Bracket	2	10-1.50mm x 40mm Carriage Bolts
2	Tube Spacers	2	10-1.50mm Hex Nuts
4	½" x 2" Hex Head Bolts	2	10mm Lock Washers
4	½" Lock Washers	2	10mm ID x 26mm OD x 3mm Flat Washers
4	½" ID x 1-1/2" OD x 1/8" Flat Washers	2	10mm Rectangular Washers

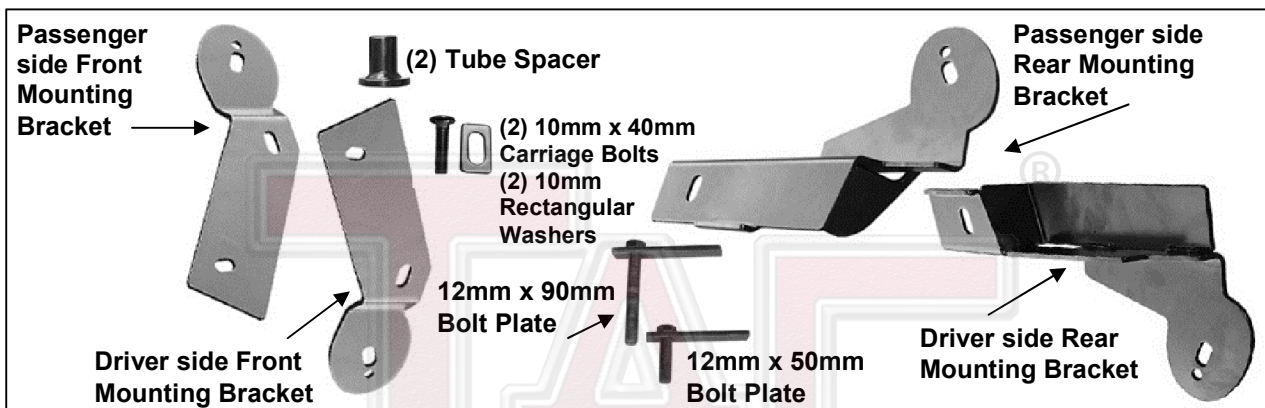

**PROCEDURE:**

1. **REMOVE CONTENTS FROM BOX. VERIFY ALL PARTS ARE PRESENT. READ INSTRUCTIONS CAREFULLY BEFORE STARTING INSTALLATION. DO NOT ATTEMPT INSTALLATION ALONE; PERSONAL INJURY OR DAMAGE TO THE VEHICLE MAY RESULT.**
2. Start installation on the passenger side-front of the vehicle. Uncover the two front mounting locations by removing the rubber plugs. Insert (1) 10mm Carriage Bolt with Rectangular Washer into the hole in the frame channel towards middle of vehicle and lock into position. Insert (1) 12mm x 90mm Bolt Plate into the factory oval hole in the frame channel. Turn the Bolt Plate 90-degrees to lock into position, **(Figure 1)**. Slide the Tube Spacer onto the long 12mm Bolt Plate and attach the front Mounting Bracket to the Bolt Plate using (1) 12mm Lock Washer, (1) 12mm Flat Washer and (1) 12mm Hex Nut, **(Figure 2)**. Secure the Mounting Bracket to the 10mm Carriage Bolt with (1) 10mm Lock Washer, (1) 10mm Flat Washer, and (1) 10mm Hex Nut. Snug hardware but do not tighten at this time.
3. Move to the rear of the vehicle and remove the oval rubber plug covering the mounting location in the frame channel. Insert (1) 12mm x 50mm Bolt Plate up into the oval hole and rotate the Bolt Plate 90-degree to lock into position, **(Figure 3)**.
4. Hold the passenger side rear Mounting Bracket up against the bottom of the floor and secure it to the Bolt Plate using (1) 12mm Flat Washer, (1) 12mm Lock Washer and (1) 12mm Hex Nut, **(Figure 4)**.
5. Carefully place the passenger Sidebar onto the Mounting Brackets and align the large oval holes in the Mounting Brackets with the threaded holes in center of the Sidebar. Secure the

**SIDE BAR  
06-12 TOYOTA RAV4**

Sidebar using (2) 1/2" x 2" Hex Head Bolts, (2) 1/2" Lock Washers, and (2) 1/2" Flat Washers. To determine the correct direction to install the Sidebar, note that the gap between the end of the Sidebar and the Step Pad goes toward the front of the Sidebar, (**Figure 5**).

6. Adjust Sidebar and tighten all hardware
7. Repeat Steps 2-6 for the driver side installation.
8. Do periodic inspections to the installation to make sure that all hardware is secure and tight.

**To protect your investment**, wax this product after installing. Regular waxing is recommended to add a protective layer over the finish. Do not use any type of polish or wax that may contain abrasives that could damage the finish.

**For stainless steel:** Aluminum polish may be used to polish small scratches and scuffs on the finish. Mild soap may be used also to clean the Sidebar.

**For gloss black finishes:** Mild soap may be used to clean the Sidebar.

**Passenger Side Front Installation Pictured**

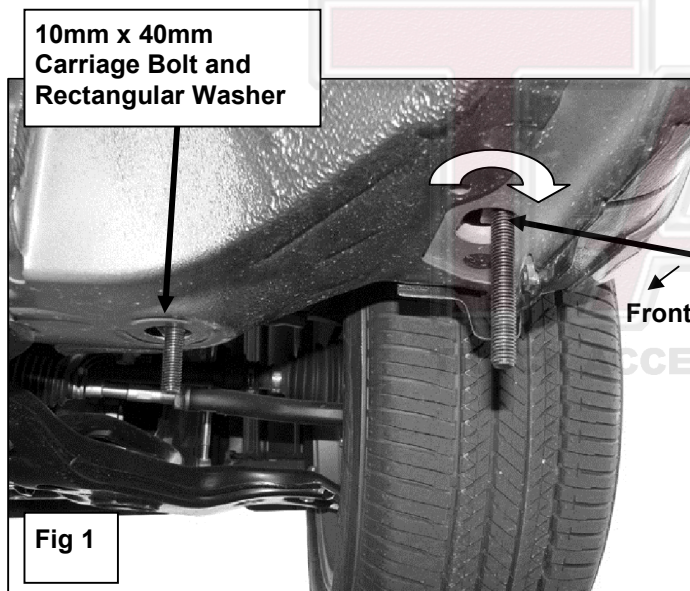

12mm x 90mm Bolt Plate (twist 90-degrees)

Install Tube Spacer on 12mm x 90mm Bolt Plate, between Mounting Bracket and Body

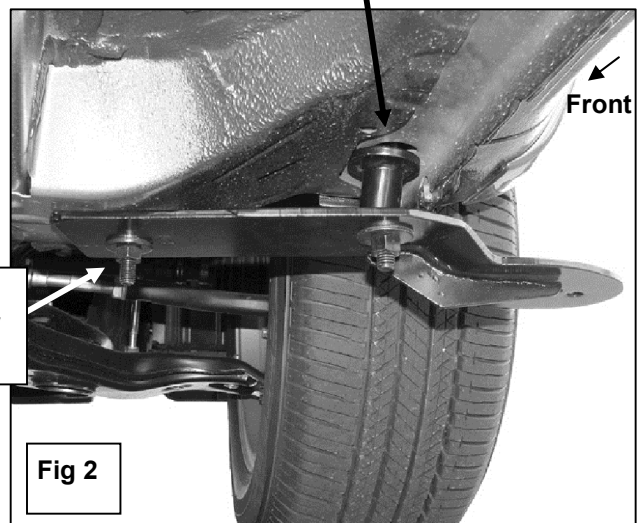

10mm Flat Washer  
10mm Lock Washer  
10mm Hex Nut

**Passenger Side Rear Installation Pictured**

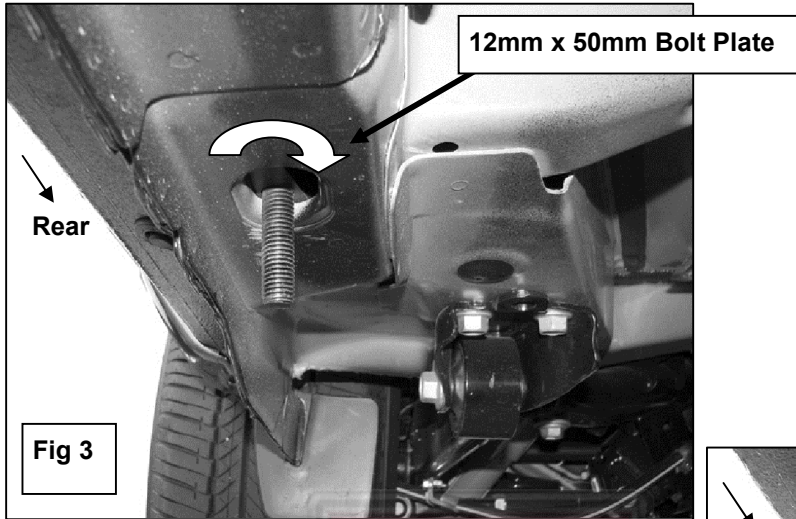

**NOTE: Driver side rear mounting bracket is slightly different than passenger side to allow for line clearance.**

