

WALL UNIT & WALL UNIT WITH HIGH MAT
ASSEMBLY INSTRUCTIONS

LEGACY[®]
PILATES APPARATUS



LEGACY[®]

PILATES APPARATUS

WHAT COMES IN THE BOX

- A. MAIN VERTICAL ASSEMBLY (1)
- B. FLOOR MOUNT ASSEMBLY (1)
- C. WALL MOUNT ASSEMBLY (1)
- D. ALUMINUM & WOOD HANDLES (2)
- E. ROLL BACK BAR SPRINGS (2)
- F. PUSH THRU SPRINGS (BOTTOM) (3)
- G. PUSH THRU SPRINGS (TOP) (2)
- H. ARM SPRINGS (2)
- I. ROLL BACK BAR (1)
- J. PUSH THROUGH BAR (1)
- K. CHAINS (3)
- L. SPRING HOOKS (18)
- M. DOUBLE HOOKED SNAPS (12)
- N. LEG LOOPS (2)
- O. LEG LOOPS (2)
- P. HIGH MAT (1)

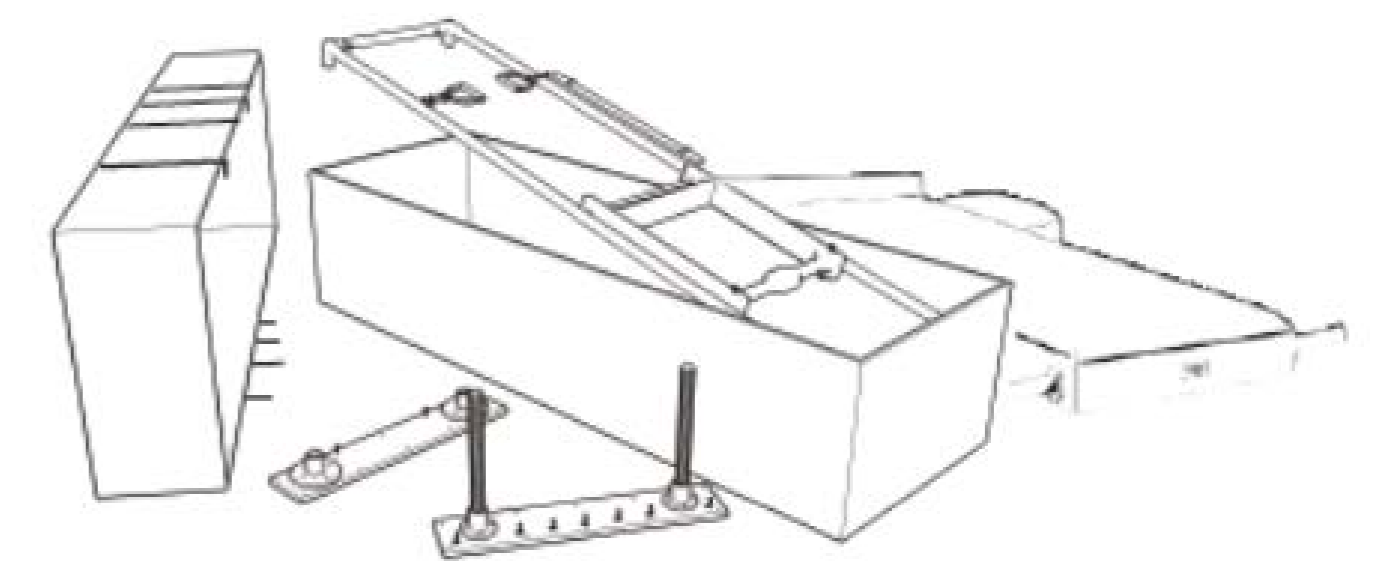
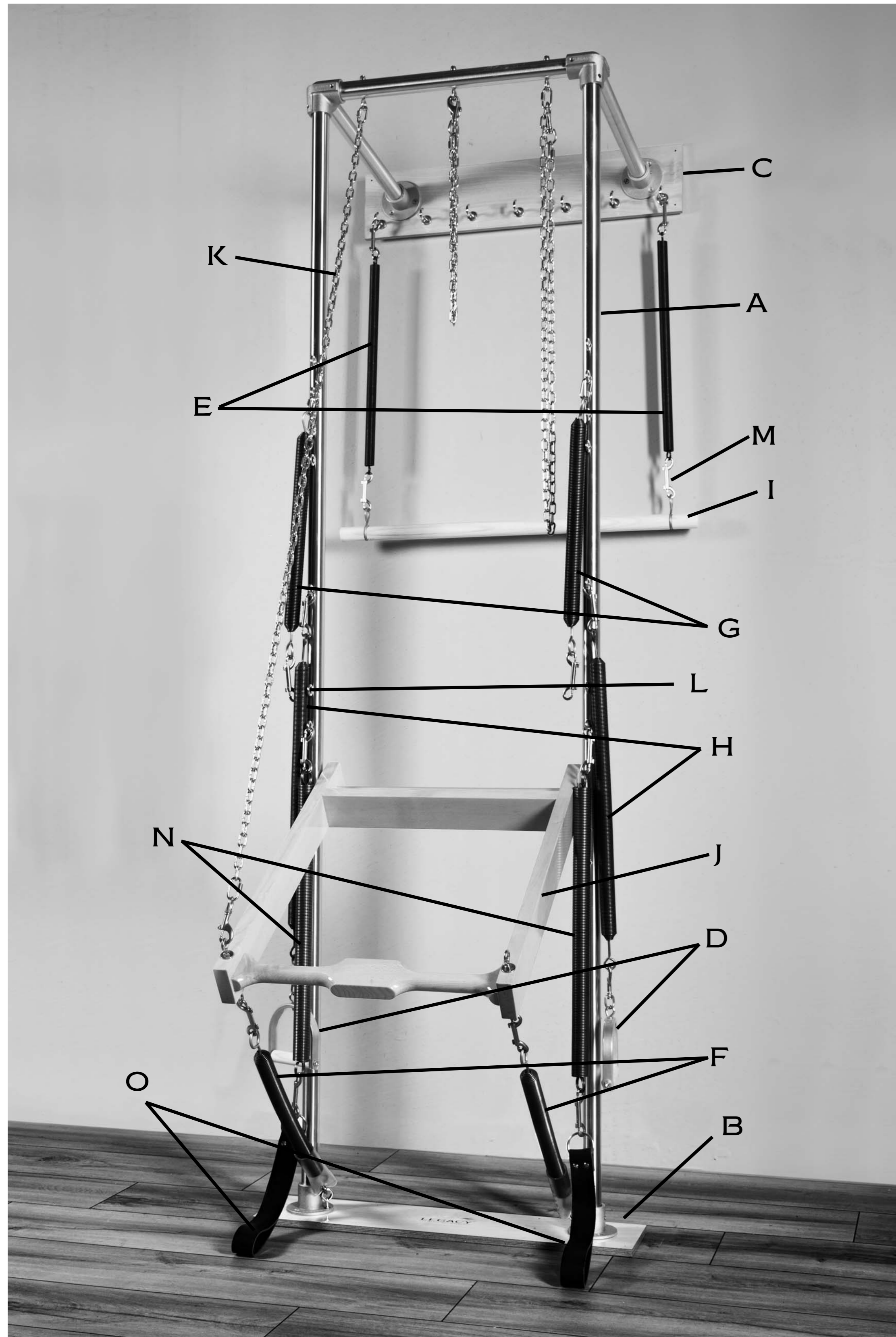

STEP 1 - REMOVE CONTENTS FROM THE BOX
PLACE THE BOX LONG SIDE DOWN. USE THE
BOX CUTTER TO CAREFULLY CUT THE TIES.

NOTE: IF YOU PURCHASED A HIGH MAT, IT
WILL BE INCLUDED IN YOUR CONTENTS.

STEP 2 - CONNECT MAIN PIECE TO WALL & FLOOR MOUNT LOCATE THE 3 MAIN PIECES AND FOLLOW THE STEPS BELOW.

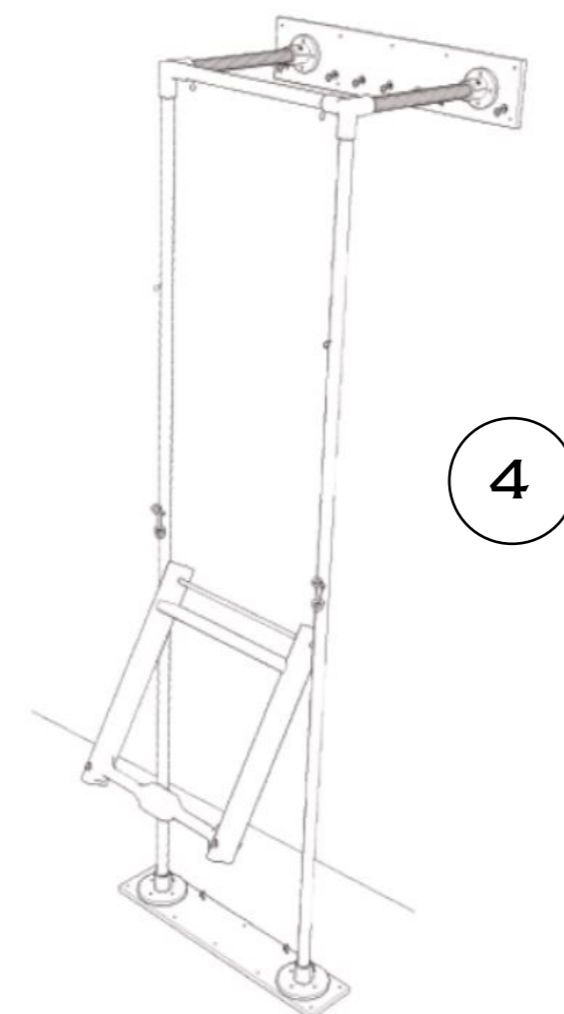
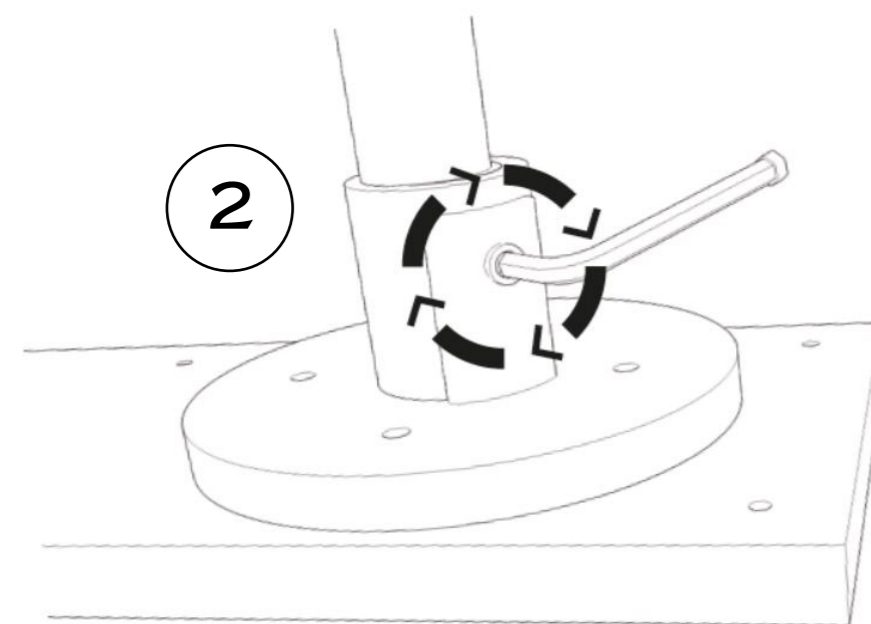
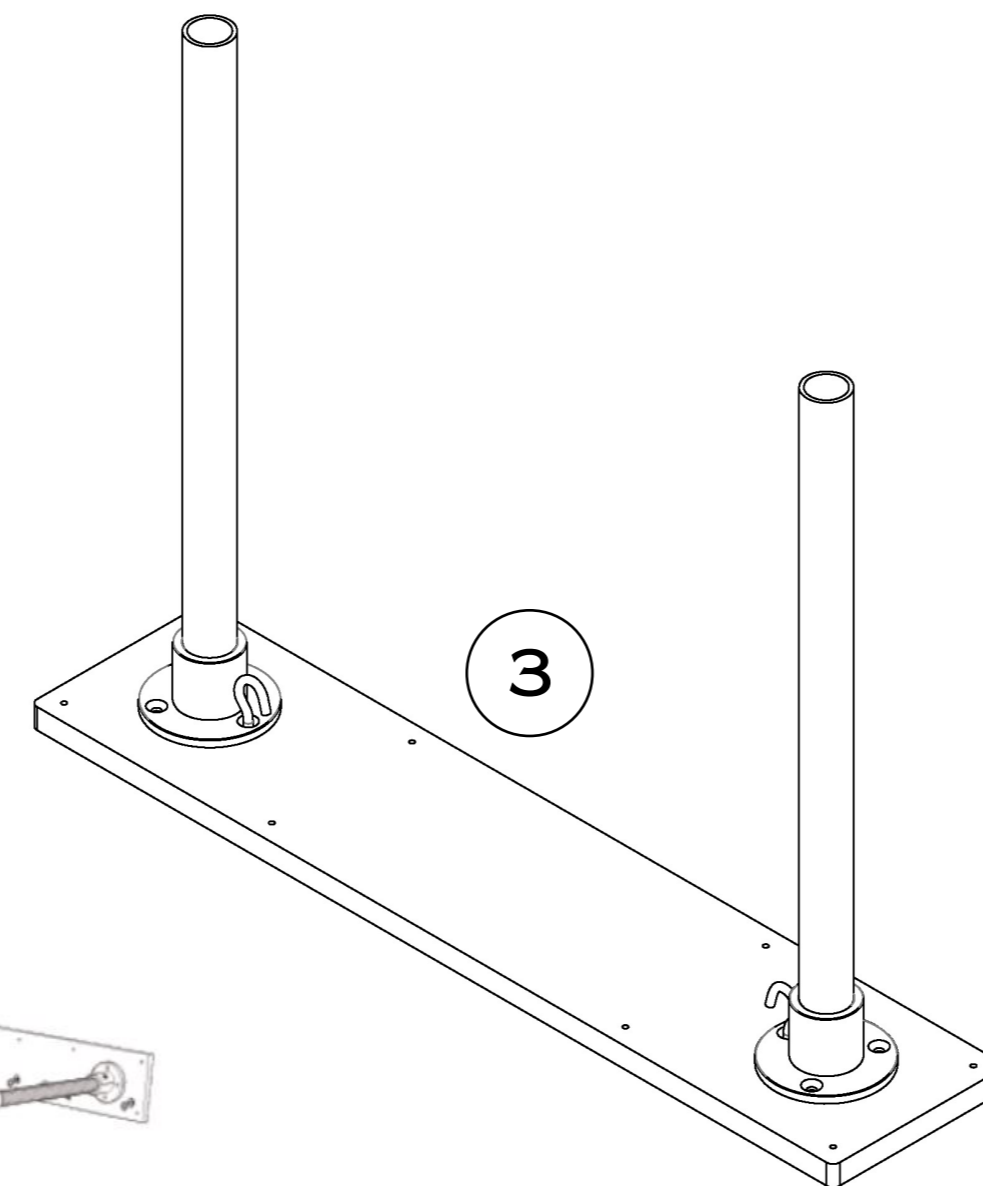
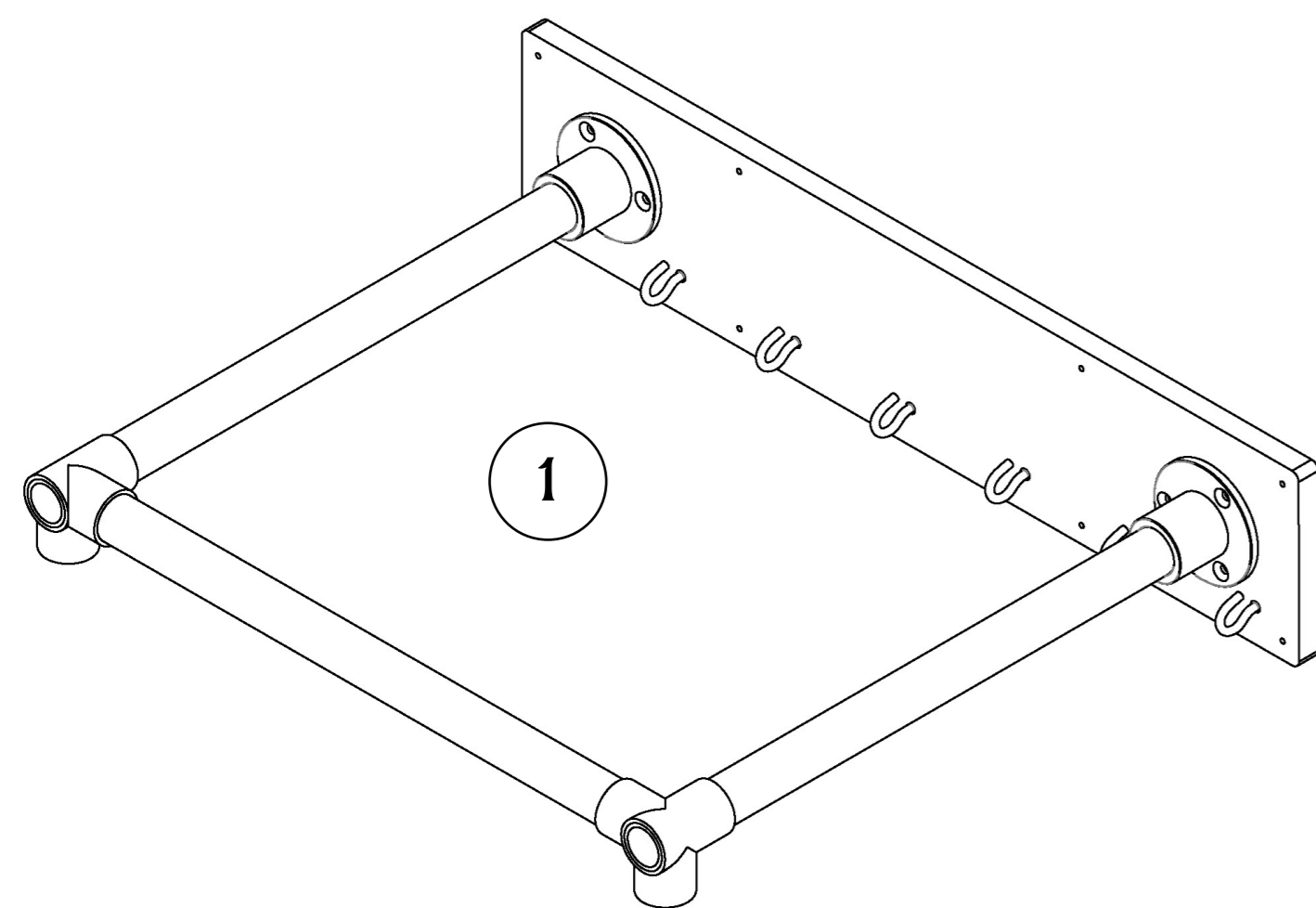
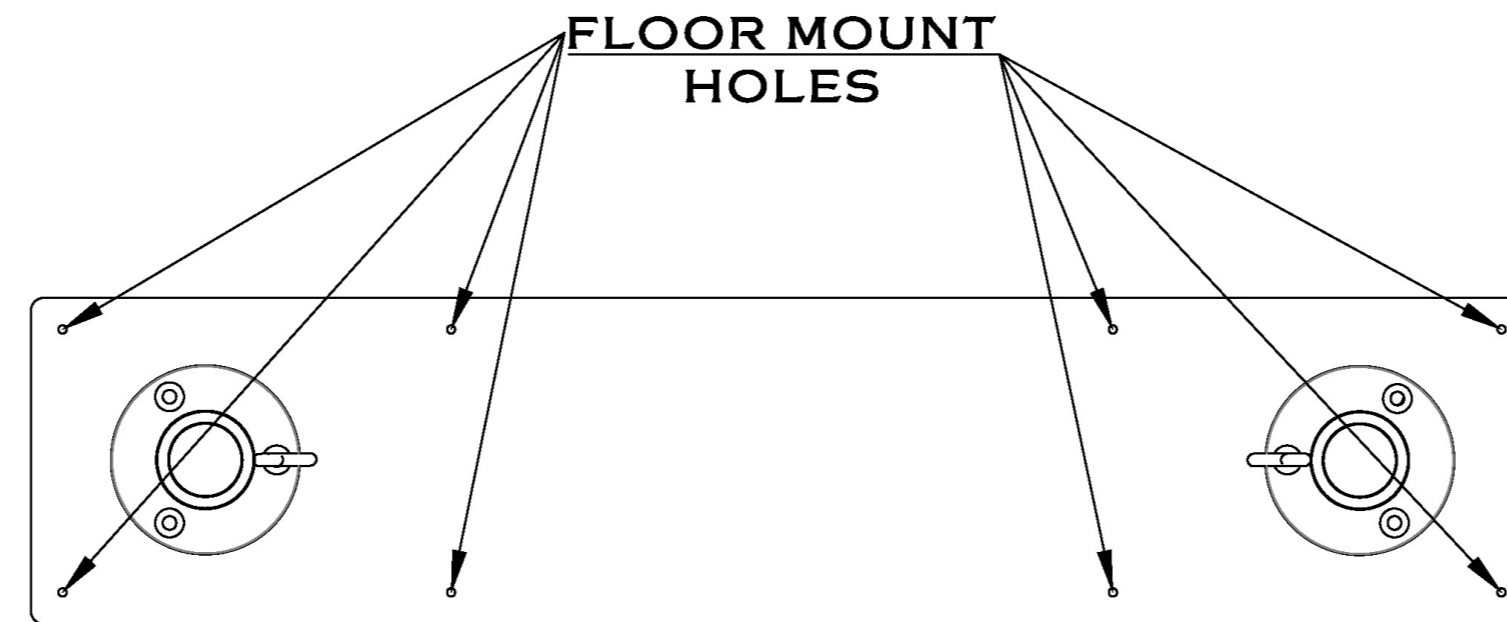
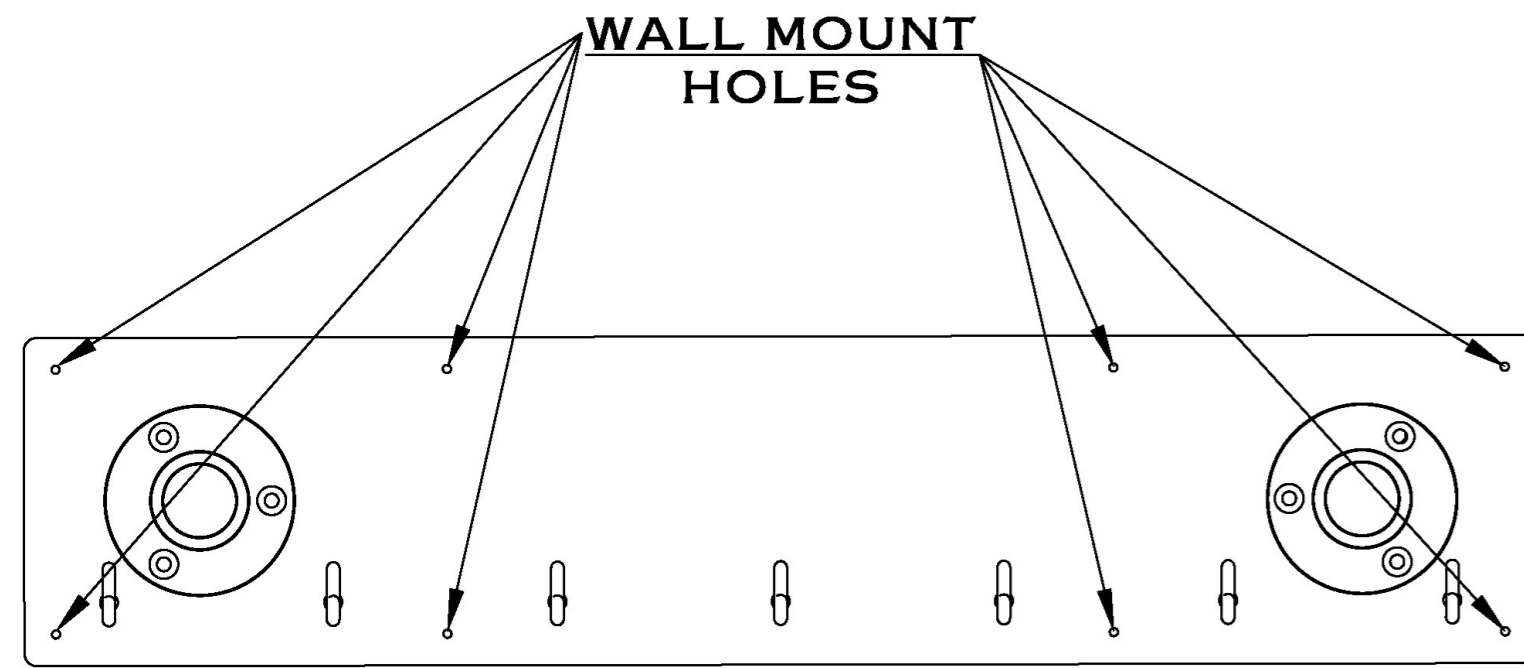

1) SLIDE THE WALL MOUNT'S TWO RODS INTO THE OPEN SLOTS OF THE MAIN VERTICAL UNIT.

2) ONCE ITS IN PLACE TIGHTEN WITH ALLEN KEYS.

3) THEN SLIDE THE MAIN VERTICAL UNIT'S TWO RODS INTO THE OPEN SLOTS OF THE FLOOR MOUNT. ONCE IN PLACE TIGHTEN WITH THE ALLEN KEY AS SHOWN IN FIGURE 3.

4) TEST AND PLACE THE ASSEMBLED UNIT DIRECTLY AGAINST DESIRED LOCATION WHICH HAS A FLAT WALL AND FLOOR SURFACE.

5) PLACE AND SECURE THE ASSEMBLED UNIT DIRECTLY AGAINST DESIRED LOCATION. PRIOR TO INSTALL USE THE LEVELING SQUARE. MAKE SURE THE FLOOR AND WALL SURFACES ARE LEVEL.

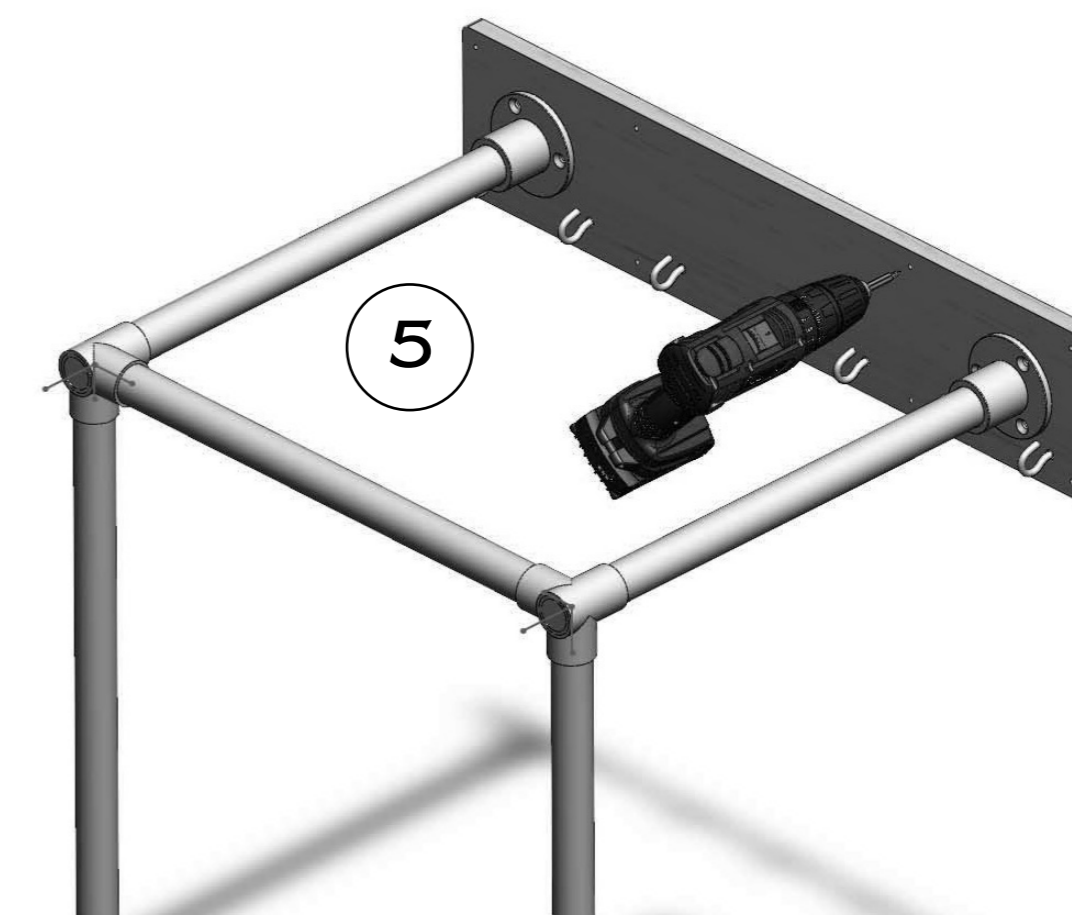

LEGACY[®]

PILATES APPARATUS

6) DEPENDING ON THE SURFACE MATERIAL YOU HAVE, YOU MAY HAVE TO USE ANCHORS WHEN SCREWING EACH MOUNT DOWN. YOU MAY USE WOOD SCREWS ON WOODEN FLOORS AND SUBSTRATES. IT IS HIGHLY RECOMMENDED THAT STONE, TILE, AND CONCRETE FLOORS ARE PRE-DRILLED AND INSTALLED WITH MASONRY ANCHORS IN THE FLOOR TO GAIN MORE STRENGTH. YOU CAN PURCHASE THESE ANCHORS AT YOUR LOCAL HARDWARE STORE. USE A DRILL TO TIGHTEN THE WOOD SCREWS THROUGH THE SUITABLE HOLES ALONG THE PERIMETER OF THE MOUNTS ONTO THE GROUND THEN THE VERTICAL SURFACE.

208,5 CM

NOTE: 208,5 CENTIMETERS FROM THE BOTTOM OF THE WALL MOUNTED BOARD TO THE FLOOR.

127 CM

202 CM

62 CM

