

Vixen®

Instruction Manual for the VC200L and VMC200L

CATAPHOPTIC

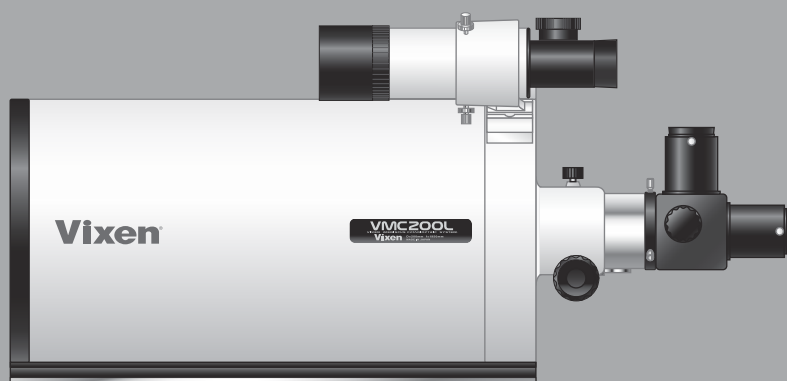
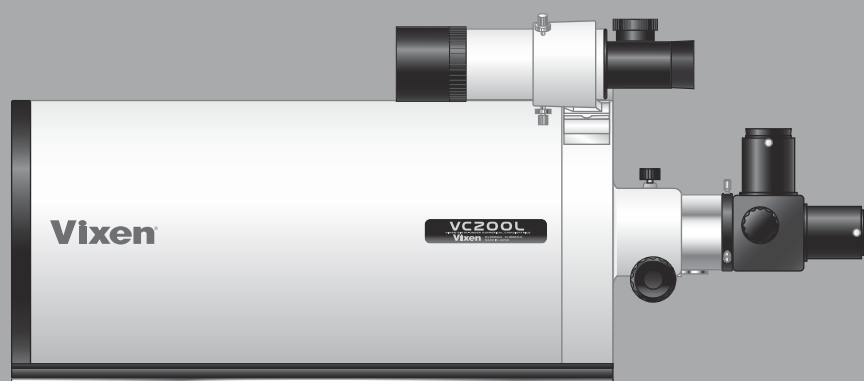

PREFACE

Thank you very much for your purchase of a Vixen catadioptric reflector.

This manual applies to the VMC200L and VC200L telescopes. You may occasionally find descriptions in the text not relevant to your particular model. The specifications in English are for export models and supplied accessories are different from the Japanese domestic models.

Read the instructions for your mount along with this manual if you purchased the telescope as a complete package.

⚠ WARNING!

Never look directly at the sun with the telescope or its finder or guide scope. Permanent and irreversible eye damage may result.

⊘ CAUTION

- ⊘ Do not leave the optical tube uncapped in the daytime. Sunlight passing through the telescope or finder scope may cause a fire.
- ⊘ Do not use the product while moving or walking, injuries could result from a collision with objects or from stumbling or falling.
- ⊘ Keep small caps, plastic bags, or plastic packing materials away from children. These may cause a danger of swallowing or suffocation.
- ⊘ Do not use the product in a wet environment and do not handle with wet hands.

HANDLING AND STORAGE

- Do not leave the product inside a car in bright sunshine, or in other hot places. Keep any strong heat sources away from the product.
- When cleaning, do not use solvents such as paint thinner or similar products.
- Do not expose the product to rain, water, dirt or sand.
- Avoid touching any lens or mirror surfaces directly with your hands. In case a lens or mirror becomes dirty with fingerprints or general smears, gently wipe it using a commercially available lens cleaner and a lens cleaning paper or cloth, or consult your local Vixen dealer.
- Blow off dust on lenses using a commercially available blower brush.
- For storage, keep the product in a dry place and do not expose to direct sunlight.

SETTING UP THE TELESCOPE

Refer to your mount instructions along with this manual.

Attaching the Telescope to the Mount

Loosen both the dovetail-plate lock screw and safety screw until the tips of these screws no longer extended into the inner part of the dovetail block.

Slide the dovetail mounted scope into the dovetail mounting block as shown in the figure. Tighten the dovetail lock screw (centered on the notch) onto the dovetail slide bar until snug.

First tighten the dovetail lock screw, and then tighten the small chrome safety screw on the dovetail mounting block until snug.

Attaching the Finder Scope

(Finder Scope and Finder Bracket may be optional at your particular model.)

Loosen the finder bracket lock screw on the telescope's finder bracket shoe. Attach the finder scope as shown in the figure and tighten the finder bracket lock screw securely.

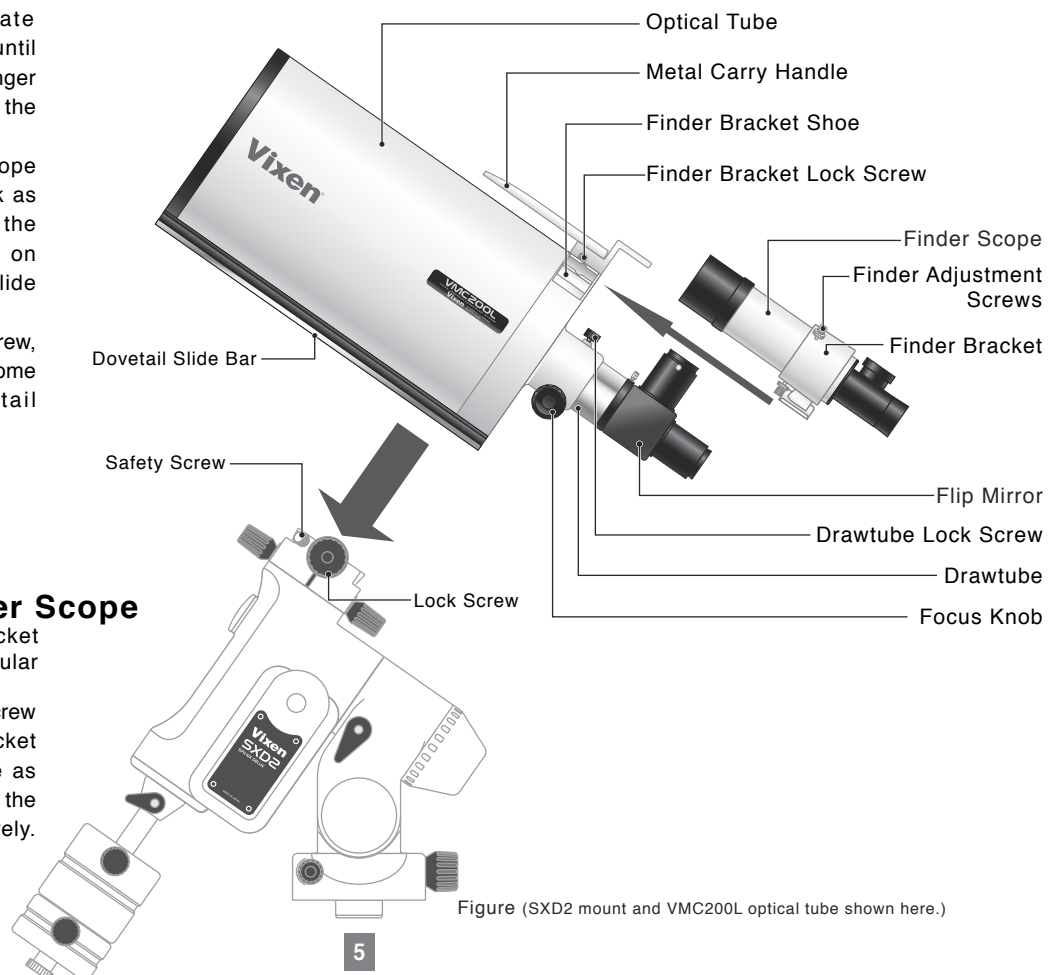
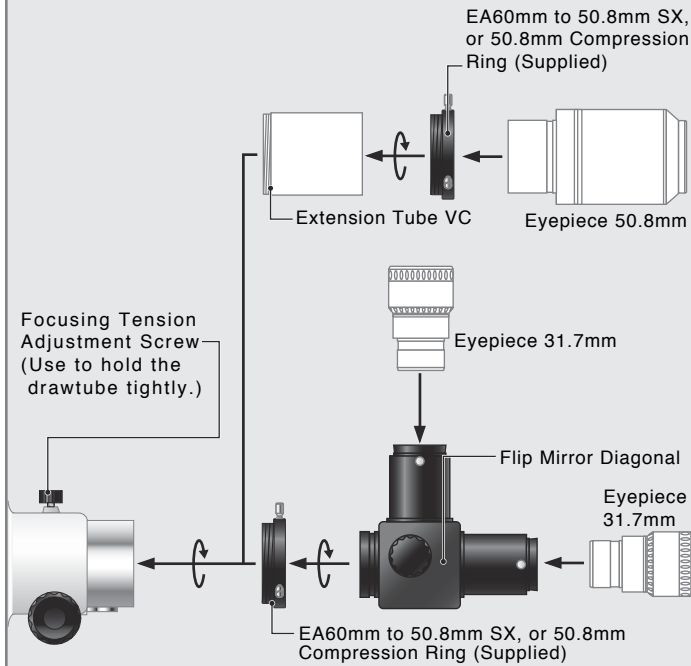

Figure (SXD2 mount and VMC200L optical tube shown here.)

OPTIONAL ACCESSORY CHART

Visual Configuration

You may need an eyepiece as sold separately. The telescope does not come with the eyepiece as standard accessory unless you purchased a package.



Magnification of the Telescope

When using an eyepiece with short focal length (small number in millimeters), the image will be dim and the range of sharp focus will be small. The image will be harder to see so begin with an eyepiece with long focal length (low magnification). Dividing the focal length of the telescope by the focal length of the eyepiece gives the magnification.

Example: Calculating the eyepiece magnification of a telescope with 1000mm focal length.

Eyepiece	Focal length of telescope	÷	Focal length of eyepiece	=	Magnification
SLV20mm	1950mm	÷	20mm	=	98x
SLV 5mm	1950mm	÷	5 mm	=	217x

Focusing the Telescope

Look into the eyepiece. The image will likely be out of focus at first. Turn the focus knob slowly clockwise or counterclockwise to find a point where the image in the field of view of the eyepiece becomes sharpest.



OPTIONAL ACCESSORY CHART

Photographic Configuration

Some of the optional accessories shown in this chart will be needed if you take pictures with (D)SLR camera, compact digital camera or CCD video camera.

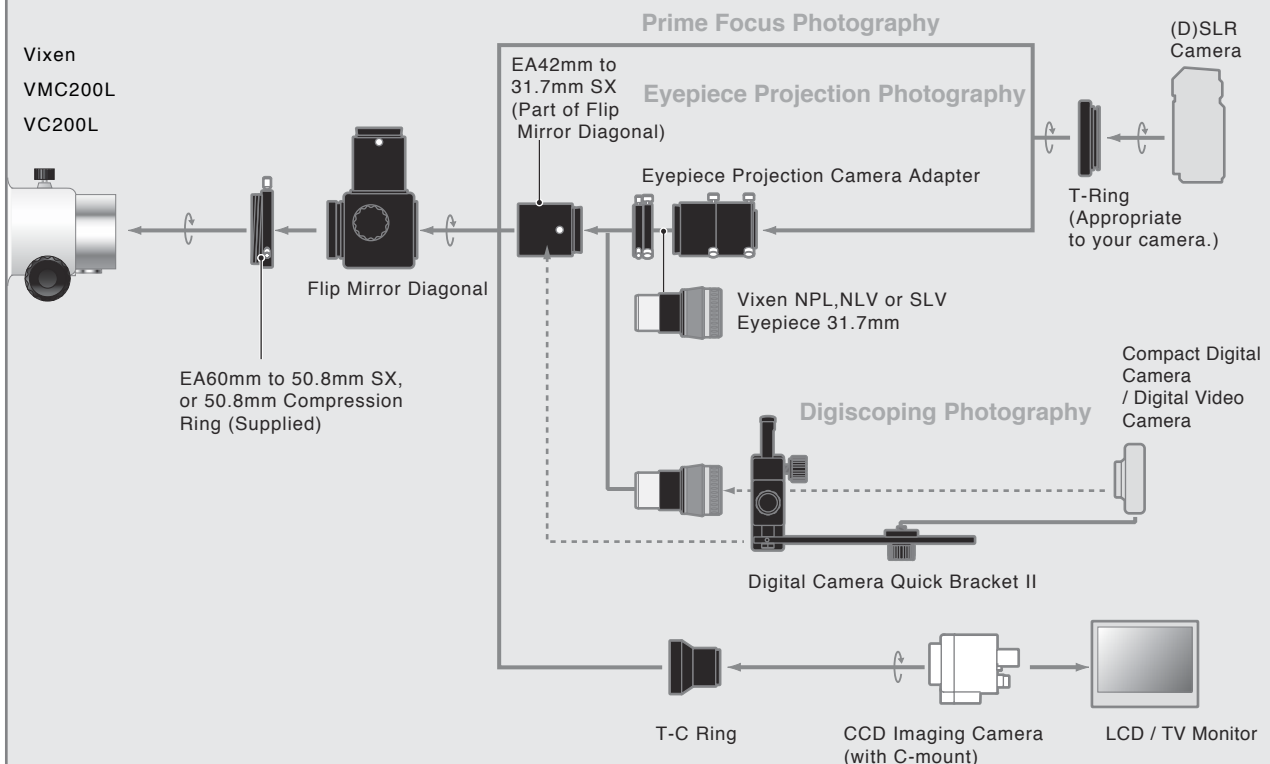

SPECIFICATIONS

Model	VMC200L(2633)	VMC200L(5829)	VC200L(5870)
Optical Design	VMC catadioptric reflector, multicoated		VISAC catadioptric reflector, multicoated
Effective Aperture (D)	200mm		200mm
Focal Length (F)	1950mm		1800mm
Focal Ratio	1 : 9.75		1 : 9
Light Gathering Power	816x		816x
Resolving Power	0.58 arc. seconds		0.58 arc. seconds
Limiting Magnitude	13.3		13.3
Drawtube Diameter : 64mm			
Threads : 60mm			
Push fit : 50.8mm, 31.7mm*(37mm is available if Flip Mirror Diagonal is supplied as standard accessory)			
Tube Length	510mm		600mm
Outer Tube Diameter	232mm		232mm
Optical Tube Weight	6.8kg	5.9kg	6.9 kg
Accessories			
7x50 Finder w/illuminated Reticle	○	X	○
Flip Mirror	○	X	○
Eyepiece Adapter	EA60mm to 50.8mm SX	50.8mm Compression Ring	EA60mm to 50.8mm SX
Dovetail Slide Bar	○	○	○
Metal Carry Handle	○	○	○

The specifications are subject to change without notice.

The supplied accessories may differ what we describe here, if you purchase a telescope/mount package.

OPTICAL ALIGNMENT

Checking the Optical Alignment

Collimated Properly

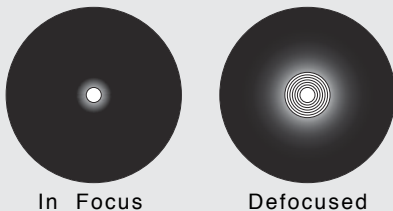

Select a second-or third-magnitude star and place it the center of the telescope's field of view by using a moderately high power eyepiece.

Focus the star precisely.

And then defocus slightly and you will look for striped patterns that surround the star.

Miss Collimated

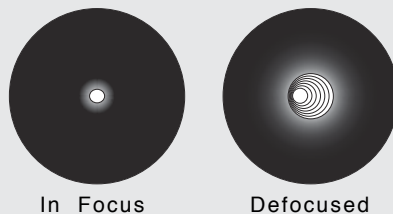

If the striped pattern can be seen as a concentric image, your telescope is properly collimated (aligned).

Vixen®