

NightShot[®]

OWNER'S MANUAL



NIGHT VISION RIFLE SCOPE

by

Night Owl Optics[®]

www.nightowloptics.com • 1-800-444-5994

Product Overview	3
Installing the Batteries	4
Mounting the Rifle Scope	5
Operation	6-7
Focusing	8
Windage and Elevation Adjustments	9-10
Power, Display and Battery Life	11
Infrared Illuminator	11-12
Specifications	13
Range	14
Troubleshooting Guide	15
Frequently Asked Questions	16-18
Recoil Recovery	19

PRODUCT OVERVIEW

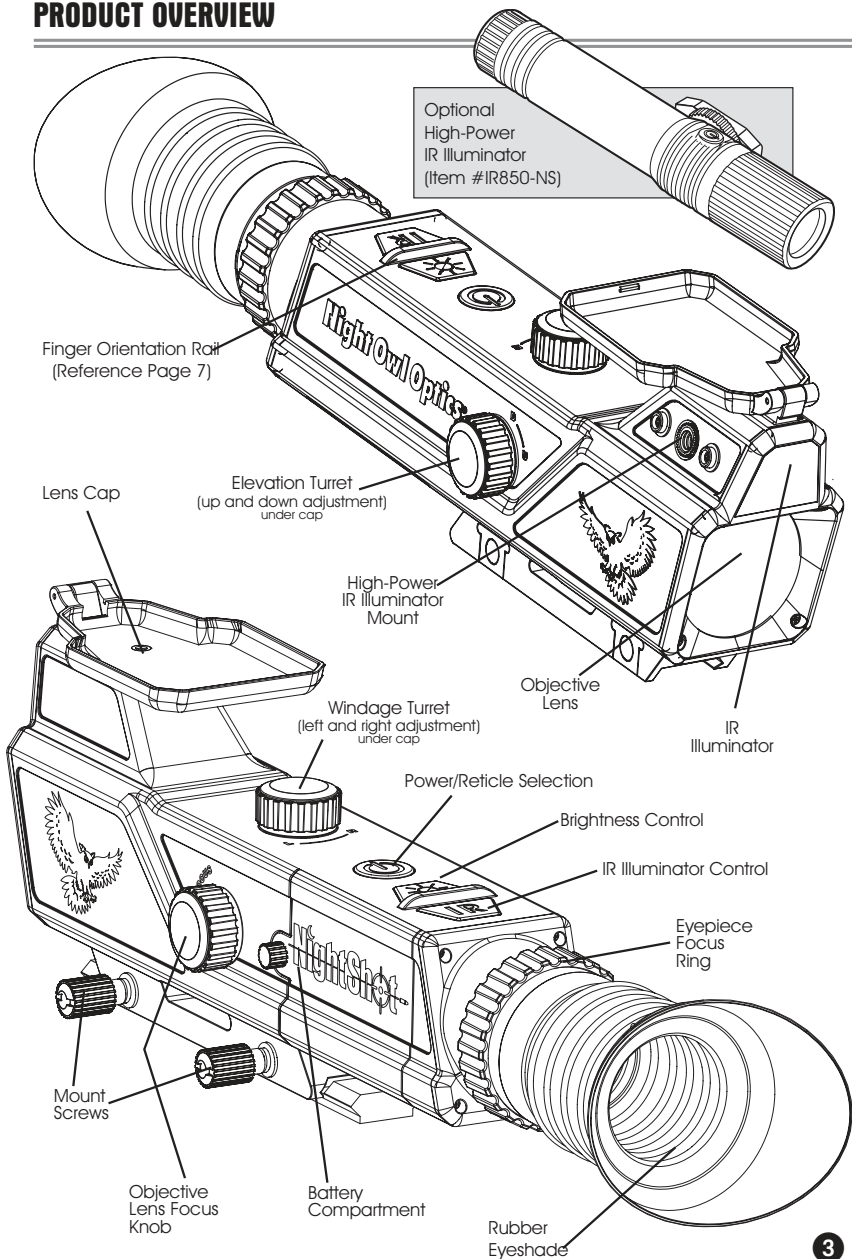

INSTALLING THE BATTERIES

The battery door is designed for a tight fit to avoid battery bounce during recoil.

1. Remove door by rotating thumbscrew counterclockwise approximately five turns. The thumbscrew is attached to door and stays attached.
2. To install door, insert the two tabs into position. Press firmly to seat the door flush. Then tighten the thumbscrew.

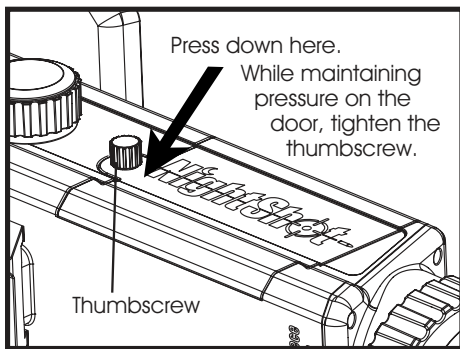

Install four
AA Alkaline or
Lithium Batteries

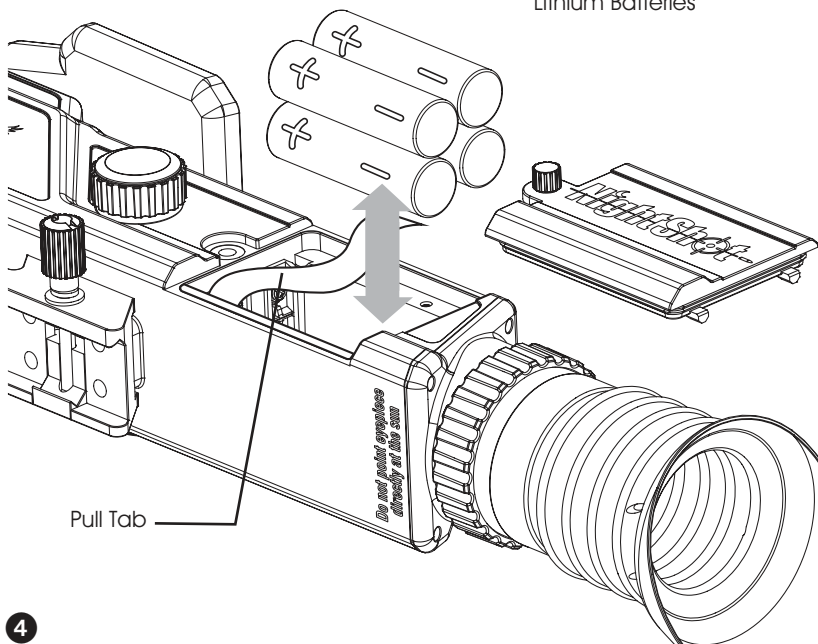

MOUNTING THE RIFLE SCOPE (Weaver or Picatinny)

A mounting rail must be attached to your firearm; NightShot attaches to the rail. If your firearm does not have a rail, have a qualified gunsmith install the mounting rail (Picatinny or Weaver rail) on your rifle. However, if you choose to self-install your mounting rail, use a high quality mounting rail and carefully follow the instructions that come with it.

Note: There are two different cross-bolts on the scope mount. The cross-bolt with the full diameter locates the scope on the rail and prevents it from moving fore and aft. The flat cross-bolt tightens the mount to the rail, but does not locate into a slot on the rail. These two cross-bolts are interchangeable and can be reversed as required to fit to your particular rail. Picatinny rails have evenly spaced cross-cuts and therefore should not necessitate moving the cross-bolts. On Weaver-style rails the location of, and spacing between, the cross-cuts can vary and thus may require reversing the cross-bolts. In mounting the scope to your rail, adjust the scope to suit your natural shooting position. The scope should sit at a safe distance away from your eye, in a comfortable position to optimize sighting and shooting. The eye relief to the lens is approximately 2.7 inches (7 cm).

Note: There is a flat spot on one of the cross-bolts. The cross-bolts can be reversed to work in different mounts particularly "weaver mounts" where the spacing between the slots varies.

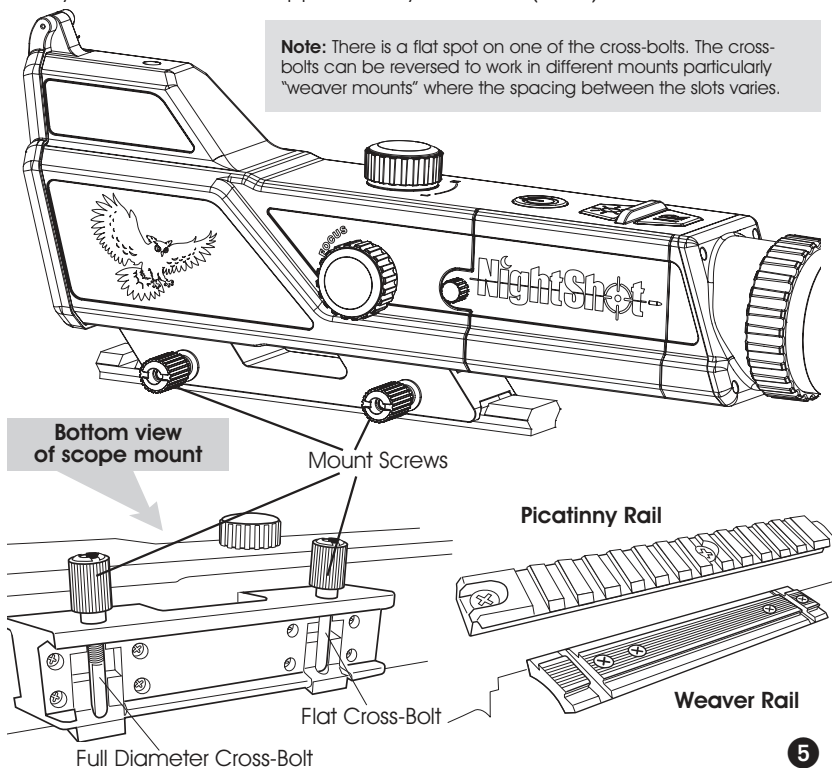

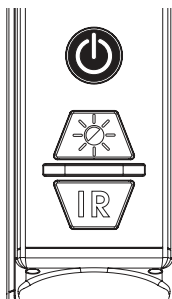

1. Power On/Off

ON: Press and hold the power button for 2-3 seconds.

OFF: Press and hold the power button for 2-3 seconds.

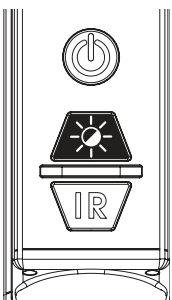

2. Brightness Control

Press the Brightness control button. The brightness will be adjusted in the following cycle (the symbol will be displayed on the screen, and will disappear after 3 seconds):

- Low 
Medium  (default)
High 

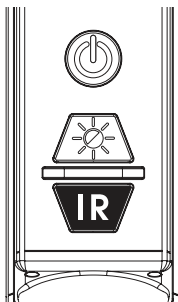

3. IR Intensity Control

Press the IR control button. The IR intensity will be adjusted in the following cycle (one of these symbols will remain on the screen):

- IR Low 
IR Medium  (default)
IR High 
IR Off 

Note: If sighting in during daylight, remember to turn off IR to conserve battery power.

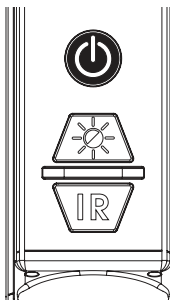

4. Reticle selection

Quick-pressing the power button cycles between 3 different reticle types. Each of the 3 reticle types can be configured in white or black, allowing the shooter to adjust the reticle type and color to best suit the current shooting environment.

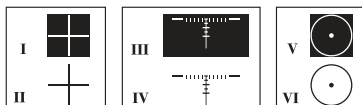

5. Memory

The following settings are saved to memory even if power is off or batteries are removed:

- IR setting
- Reticle selection
- Brightness
- Windage and Elevation (as long as the protective caps are installed)

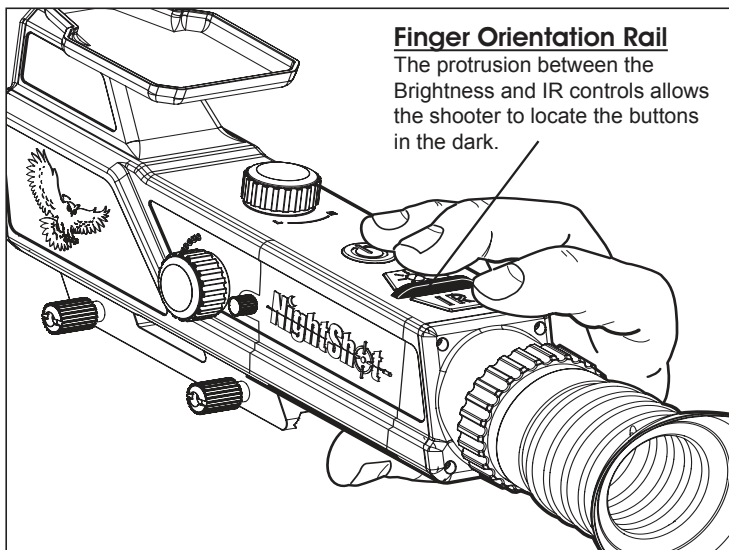

Finger Orientation Rail

The protrusion between the Brightness and IR controls allows the shooter to locate the buttons in the dark.

FOCUSING

EYEPIECE FOCUS - STEP 1

- ① Close the Lens Cap.
- ② Select a white reticle by quick-pressing the power button.
- ③ Set Eyepiece focus to your individual eyesight by pressing any button to display a graphic on the screen. Adjust eyepiece until the graphic comes into sharp focus on the display.

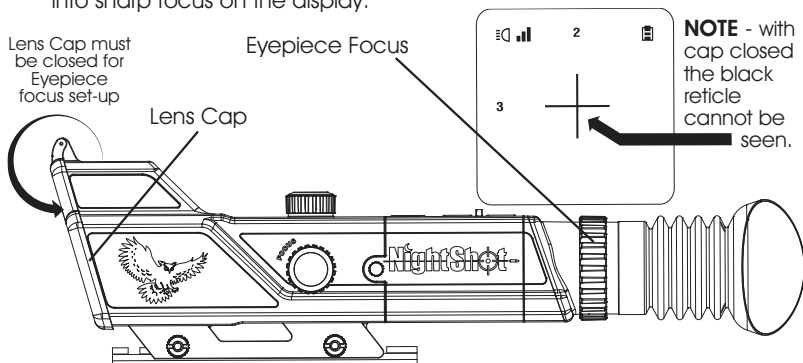

Set Eyepiece Focus once only. **Do not readjust** unless a different shooter uses the scope.

OBJECTIVE LENS FOCUS - STEP 2

After setting Eyepiece Focus:

- ① Open Lens Cap.
- ② Use Objective Lens Focus Knob to bring distant objects into focus.

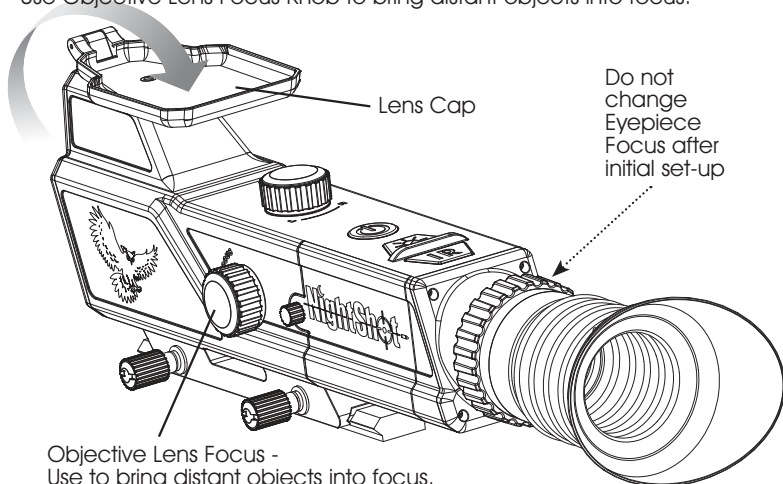

WINDAGE and ELEVATION ADJUSTMENTS



- Remove protective cap.
- Rotate turret in the U or D and/or L or R direction.
- One click equals approximately 1/4" adjustment at 50yds.

Protective Caps are designed to avoid overtightening. Rotate to fit snug & seal. Thread will slip if too tight.

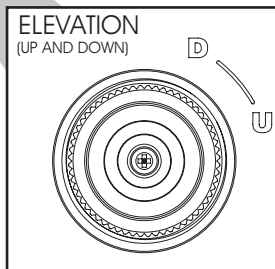
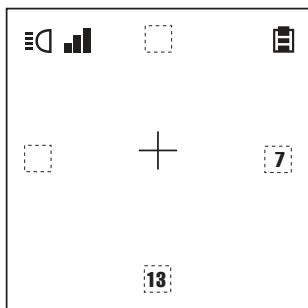
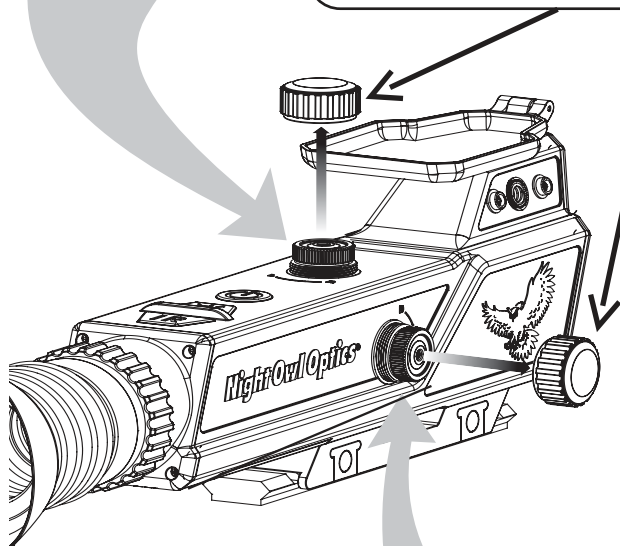

Bore Sighting:

Bore sighting is the procedure required to align the scope with the rifle bore. This can be done with the assistance of a bore sight device or, if one is not available, this can be accomplished as follows:

1. Lock or mount the gun in a stationary device so it cannot move. Remove the bolt and look through the barrel at a target that is set at 50 yards or further. Identify the center point spot inside the barrel window on the target.
2. Now look through the scope and set your reticle to the same center point spot on the target by utilizing the scope's windage and elevation adjustments.
3. After bore sighting the firearm, it is necessary to perform a final sight-in at the range to insure accuracy. **Important:** make final sight-in adjustments with the ammunition you intend to use.
4. **Take note of the numerical windage and elevation values.** This is your new center-point for this scope on this rifle. If you remove the scope from this rifle and then later reinstall, reset the windage and elevation to these values.

WARNING: Do not point EYEPIECE directly at sun. Prolonged exposure can damage optic.

Zeroing:

Final zeroing should be done at the distance where you do most of your shooting. For most hunters using night vision, this will be in the 50-100 yard range.

Windage and Elevation:

To adjust windage and elevation on the NightShot rifle scope:

1. Remove the protective caps from the windage and elevation adjustment turrets by rotating counterclockwise.
2. On the windage adjustment, Left and Right are indicated by L and R. On the elevation adjustment, Up and Down adjustments are indicated by U and D.
3. To make adjustments to the point of impact (POI), click the turret in the required direction, taking into account that 1 click equals 1/4 inch at 50 yards. For example, if it were necessary to adjust POI by 1 inch to the right, you would click the windage turret towards "R" 4 times to equal 1 inch.
4. Once complete, re-install the protective caps.

POWER, DISPLAY and BATTERY LIFE

This device uses 4 x AA alkaline or lithium batteries. When the battery voltage is too low, the device will not operate. The battery indicator will flash when the battery voltage is low.

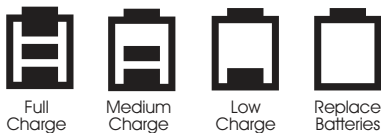

Expect approximately 4 to 7 hours of battery life under normal use with quality alkaline batteries. The use of lithium batteries is highly recommended, as lithium batteries will significantly increase battery life. **Note:** the IR uses the majority of the battery power, so if the IR is left on, the battery life decreases significantly. If the scope is left on, consider setting IR to "Off" or "Low", then switch to a "High" setting IR intensity when targeting.

Expected operating time on one set of good-quality alkaline batteries:

- 4 hours with IR on High.
- 7 hours with IR on Low.

Device will not turn off automatically. Therefore, to conserve battery power consider turning the IR to "Low" or "Off" when extra illumination is not required.

INFRARED ILLUMINATOR (IR)

The NightShot is equipped with an active infrared emitter (IR); it emits an invisible beam of infrared light. The beam of light exiting the emitter is not visible to human or animal eyes, but is detected by the NightShot sensor. Also notice that while the light emitting from the IR is invisible, the diode does glow inside the emitter and you can detect it from a distance. Extensive testing concludes that animals are not influenced by the glow of the infrared emitter.

IMPORTANT

While invisible, the IR is a bright light. If reflective objects are at close range between you and your target, the IR can reflect back at you, introducing excess light into the scope and causing a bright, overexposed, image.

The following can reflect the IR light back at you:

1. A reflective surface on the firearm or in front of the NightShot. This might be a shiny/reflective target, an iron sight or, for example, a nickel-plated barrel.
2. Using the NightShot in closed spaces may cause the IR to reflect back into the scope.
3. Looking through windows can cause the IR to reflect back into the scope. **11**

ACCESSORY INFRARED ILLUMINATOR:

An optional High-Power Infrared Illuminator is available (item# IR850-NS).

Consider purchasing the optional accessory high-power IR Illuminator. It attaches to the side of the scope. Using the accessory IR, you can turn off the main IR, and almost double NightShot's battery life. The accessory IR uses its own batteries, type 123. The accessory IR item # is IR850-NS.

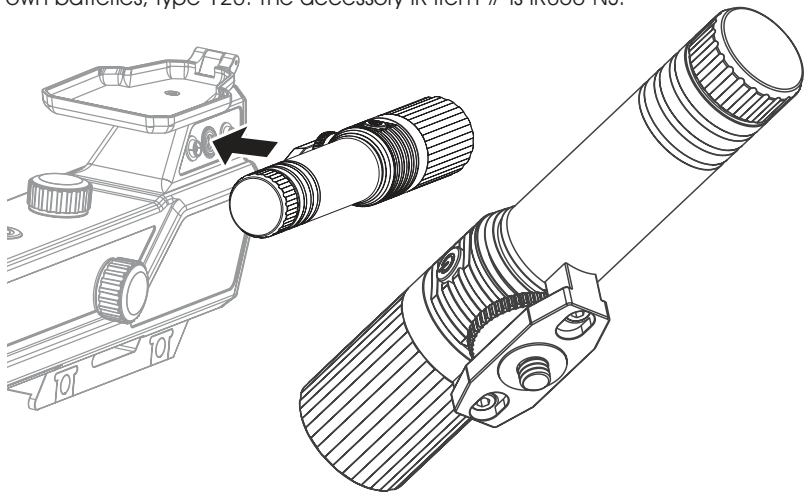

- Custom Designed for use with Night Owl Optics NightShot Digital Night Vision Riflescope
- High-Power Infrared LED Emitter
- Power: 1000mW
- IR Wavelength: 850nm
- Easy-To-Use
- Weatherproof
- Weight: (without batteries) 3.427 oz - 97.2 g
- Weight: (with 2 123-type batteries) 4.573 oz - 129.7 g
- Dimensions: 135mm x 40.4mm
- Lens Diameter: 22.8mm
- Power: 2 123-type batteries
- Attaches to NightShot built-in mount.

**Keep this device
out of the reach of children.**

Do not look directly into the IR emitter at close range. The IR, while not visible, is still a bright light. As with any bright light, avoid pointing directly into your eye.

SPECIFICATIONS

Electronic Viewing System

Resolution	640 X 480 pixels (VGA)
Effective Spectral Range	400nm to 900nm
Frame Rate	30 fps (frames per second)

Illumination

IR LED (collimated)	15 deg. 850nm, 1000mW
---------------------	-----------------------

Eyepiece

Eye Relief	68.50mm (2.7 in)
Entrance Pupil	9.0 mm (.35 in)
Diopter Adjustment	+4D ~ -4D

Objective Lens

Focal Length	52 mm (2.05 in)
Field of View	5.6 deg.
Aperture	40mm Dia., (1.57 in) F:1.3
Focusing Distance	3M to Infinity - (10ft to infinity)

Scope

Effective Magnification	2.7X
Weight without batteries	500 g (1.10 lb)
Dimensions	335 X 69 X 102 mm 13.19 x 2.71 X 4.01 in

Power	4 pieces, AA-type Battery
--------------	---------------------------

Weatherproof	IPX4
---------------------	------

RANGE

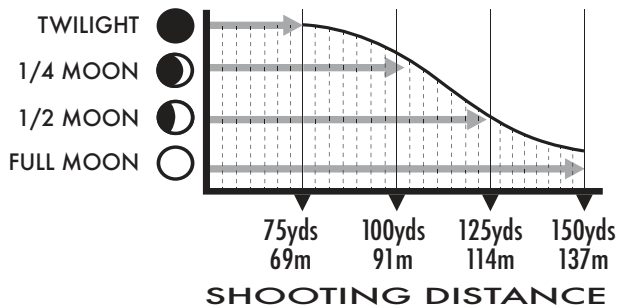

The ability to see at greater distances is relative to the amount of available ambient light. Shooters report targeting up to 250yds at night.

WARNING

DO NOT POINT EYEPIECE DIRECTLY AT SUN

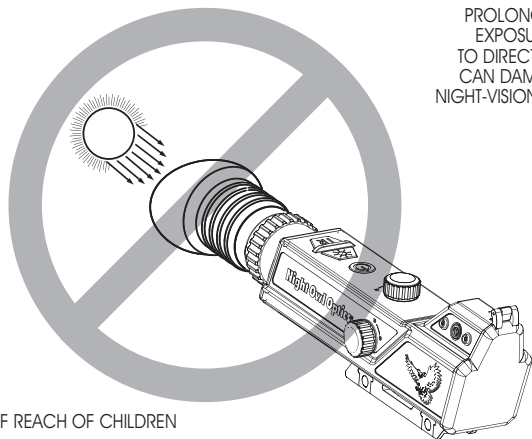

KEEP OUT OF REACH OF CHILDREN

TROUBLESHOOTING GUIDE

PROBLEM	SOURCE	SOLUTION
Short Battery Life.	Using Low Quality Batteries.	Use high-quality Alkaline or Lithium Batteries. Some brand-name batteries (especially club-bought) may last only 15 minutes. Good batteries can last 4 to 7 hours. (7-17 hours with lithium)
Cannot focus.	Night Scopes focus differently than Day Scopes.	Follow a 3-step process (Reference p.8 in this manual) 1. Shut Lens Cap and focus on Display with Eyepiece Focus Ring. 2. Open Lens Cap and aim at target in the distance. 3. Turn Objective Lens Focus Knob, on left side of scope, to bring distant objects into focus.
Shooting High; Cannot adjust reticle to get impact point down to center of target.	High rail; the rail is higher than 2 inches above the center line of the gun barrel.	Call us at 1-800-444-5994, and we will send you, at no charge, a SHIM-KIT. You can install it in approx. 5 minutes with a phillips head screwdriver.
Scope turns Off momentarily after a shot.	Mounting on very high recoil weapon.	The NightShot will turn itself back on in less than one second. By the time you can re-sight target after recoil, the scope will be on.
<ul style="list-style-type: none"> • Bright Spot • Reflection • Excessively bright image • Washed-out • Overexposed image 	1. Highly reflective surfaces on firearm or in front of the NightShot. 2. Using the NightShot in closed spaces may cause IR to reflect back into the scope. 3. Looking through windows can cause the IR to reflect back.	1. Cover up shiny surfaces. 2. Remove Iron Sight.
Cannot see paper target if the target is reflective or light colored.	Reflective or light colored targets	1. Use Darker Targets. 2. Don't use High-Gloss Targets 3. Tilt the Target so IR reflection is not directly back at you.

FREQUENTLY ASKED QUESTIONS

Q: *The lens cover is on a loose hinge; it seems flimsy.*

A: The lens cover is purposefully designed on a floating hinge to be durable and flexible. This design reduces the chance of catching on something.

Q: *How far can I see?*

A: Users report targeting out to 100/250 yards at night. The ambient light conditions will determine how far you can see. Most night hunting is at a range of 50 to 100 yards.

Q: *Will NightShot hold zero after dismount and remount?*

A: Yes, it will maintain zero. Be sure to place the scope back at the same position on the rail.

Q: *Will the NightShot mount directly to your firearm?*

A: You must have a mounting rail attached to your firearm. The NightShot attaches to the rail of the firearm using a Weaver or Picatinny rail mount.

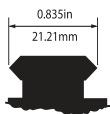

NightShot mounts directly to
WEAVER or PICATINNY RAIL MOUNT

Note: Weaver and Picatinny
are the same .835 dimension

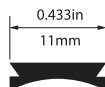

DOVETAIL RAIL MOUNT

If you have a Dovetail rail as shown, you will need an adapter rail to convert this from Dovetail to Picatinny. Most Dovetails are 11mm, however, they can range in size for 9.5mm to 19mm. In any case, an adapter rail would be required.

Q: *Why is the NightShot made from plastic?*

A: The body is constructed of a specially compounded thermoplastic, designed to be durable and lightweight. Many military grade night vision devices are constructed of plastic as well.

Q: *Can I use the NightShot with the IR Off?*

A: While IR illumination is not required in elevated ambient light conditions, in low-light conditions (e.g. twilight) the IR is required.

Q: *How do I use the IR for hunting in the shadows?*

A: If hunting by moonlight, the IR may not be required at full power in an open field. But if you aim into the shadows (e.g. under a tree), you will need the IR illumination, usually at full power.

Q: *Can the NightShot zoom?*

A: No. The NightShot is fixed 2.7X magnification night vision technology. It does not zoom the same way a Day Scope does.

FREQUENTLY ASKED QUESTIONS Continued

Q: *How is using a Night Scope different from using a Day Scope?*

- A:**
1. **FOCUS:** Setting the optical focus to your individual eyesight is different with a Night Scope. When adjusting the focus on a Day Scope, you look at the target and then adjust the eyepiece, **Night Scopes require you to look at the display screen and focus your eyesight on the screen.**
 2. **VARIABLE MAGNIFICATION:** Day Scopes use an adjustment ring for variable optical magnification. A Night Scope does not have this ring. The ring in front of the rubber eyeshade is for **FOCUSING** to the user's eyesight.
 3. **OPTICAL CLARITY:** Day Scopes look directly at the target through lenses. Night Scopes reproduce a light-amplified image on a pixelated display screen.

Q: *Can I use the NightShot in daylight?*

- A:** Yes, it is okay to use during the day. The NightShot is designed to amplify light, so pointing towards the sun will over-expose the image. If sighting in the scope during the day, keep the sun at your back.

Q: *Will Bright Light damage the scope?*

- A:** The NightShot is **not subject to bright light damage** the way traditional intensifier tube technology is. **CAUTION:** Prolonged exposure of the eyepiece to direct sunlight can damage the eyepiece optic.

Q: *What is a Digital Night Vision Scope?*

- A:** NightShot uses optics, electronics and, if necessary, an active infrared illuminator to amplify light. Bright light will not damage the sensors. Conventional Night Scopes use image intensifier tubes that degrade with use and can burn out when exposed to bright light.

Q: *Can prey animals see the glow of the IR?*

- A:** Extensive testing and user feedback concludes that animals do not react to, or perceive, the IR glow.

Q: *What is the highest recoil that NightShot is rated for?*

- A:** The NightShot is rated up to .300 caliber firearms (example, 30-60, .308). The NightShot is not rated for .300 Magnum calibers (example, 300 Winchester Magnum).

FREQUENTLY ASKED QUESTIONS Continued

Q: *How can I increase battery life?*

A: 1. Purchase the accessory IR (IR850-NS), so that the 4 X AA batteries are not powering IR
2. Operate at max-IR only when required.
3. Low IR setting is good in most settings and results in substantial power savings versus the high setting.

Q: *Does NightShot work straight out of the box? Any software updates?*

A: NightShot is turn-on-and-go. No complicated set-up or software loading.

Q: *Why is the image not green, like some other night vision scopes?*

A: Traditional night vision containing an image intensifier tube has a green-colored screen for high resolution. NightShot uses digital monochrome technology.

Q: *Can the scope shut off momentarily after a shot?*

A: The scope can momentarily experience a shut-off during high/sharp recoil impacts, which might come from large caliber rifles, piston type pellet guns and even some crossbows. There are many variables to each of these which can contribute to the possibility of a momentary shut-off (bullet weight, barrel length, firearm weight, etc). But the scope is designed and tested to absorb these impacts without damage to the scope, and if the impact is sharp enough to cause a momentary shut-off (which is actually a result of the instantaneous spring bounce on the batteries), the scope will turn itself back on in approximately 1 second, retaining all settings. In most cases the user may never know the shut-off occurred by the time the user's eye is refocused on the target after the shot.

Q: *Can I use NightShot together with another scope?*

A: No. NightShot is a stand-alone night vision scope.

Q: *How is NightShot technology different than Gen1 or Gen2?*

A: Night scopes using Gen1, 2 or 3 image intensifier technology use vacuum tubes. Such tubes degrade with use and can be damaged by bright light. NightShot is solid-state technology and is not damaged by exposure to bright light.

Q: *Why can't I lock down the turret protective caps?*

A: The protective caps are designed to slip a thread if overtightened. Rotate clockwise until snug to secure in place. They are designed this way to protect the turret components.

RECOIL RECOVERY

In the event that the shock impact exceeds the capability of this scope, the batteries may momentarily lose electrical contact, resulting in a momentary blank display on the scope. This scope incorporates a feature to recover power, and retain all settings. If this happens, the scope will automatically restore power in approximately one second. The shooter may notice a brief flicker of the display.

WARNING:

Use of this scope with higher than rated calibers VOIDS the warranty.

Applications:

- Rifle
- Paint-ball
- Pellet gun
- Crossbow

This scope is intended and warranted for use with rifle calibers of .300 and lower (non-magnums). In some instances given bullet size and weight, along with barrel length, impact can be higher or lower.

One-Year Limited Warranty

The NightShot Rifle Scope is warranted against defects in materials and workmanship under normal use for one year from the date of purchase to the original owner.

Damage due to neglect, accidental damage or misuse of this product is not covered under this warranty. Decisions regarding abuse or misuse of the product are made solely at the discretion of the manufacturer.

Proof of Purchase is required to make a claim under this warranty.

Liability under this warranty is limited to replacing or repairing, at our option, the NightShot returned, shipping cost prepaid, to Night Owl Optics.

To return your scope for service, please first contact us for a
Return Authorization (RA) Number.

NOTICE TO CUSTOMERS OUTSIDE THE U.S.A.

This warranty may vary in other countries; check with your distributor for details.
Warranty does not cover shipping costs to or from the U.S.A.



Keep this device out of the reach of children.

Night Owl Optics[®]

**1120 Alza Drive, El Paso, TX 79907
800-444-5994**

Warranty Service: service@nightowloptics.com
www.nightowloptics.com

Copyright© Night Owl Optics[®], 2021

All rights reserved, including the right to reproduce this manual, or parts thereof, in any form.
Night Owl Optics[®] and NightShot[®] are registered trademarks of Night Owl Optics.