

EXPLORE[®]
SCIENTIFIC

N208/812 Newton

208/812 (8") · f/3.9

Parabolic Newtonian Reflector

Item # BR-N20839
Item # N208CF



INSTRUCTION MANUAL



These operating instructions are to be considered a component of the device.

Please read the safety instructions and the operating instructions carefully before use.

Keep these instructions for renewed use at a later date. When the device is sold or given to someone else, the instruction manual must be provided to the new owner/user of the product.

RISK of physical injury!

Never look through this device directly at or near the sun. There is a risk of **BLINDING YOURSELF!**

Children should only use this device under supervision. Keep packaging materials (plastic bags, rubber bands, etc.) away from children. There is a risk of **SUFFOCATION.**

Fire/Burning RISK!

Never subject the device - especially the lenses - to direct sunlight. Light ray concentration can cause fires and/or burns. **RISK of material damage!**

Never take the device apart. Please consult your dealer if there are any defects. The dealer will contact our service center and send the device in for repair if needed.

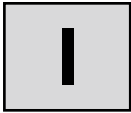

Scope of delivery

Fig. 1

A



B



C

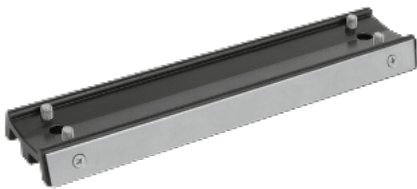

D





Parts Overview

Fig. 2

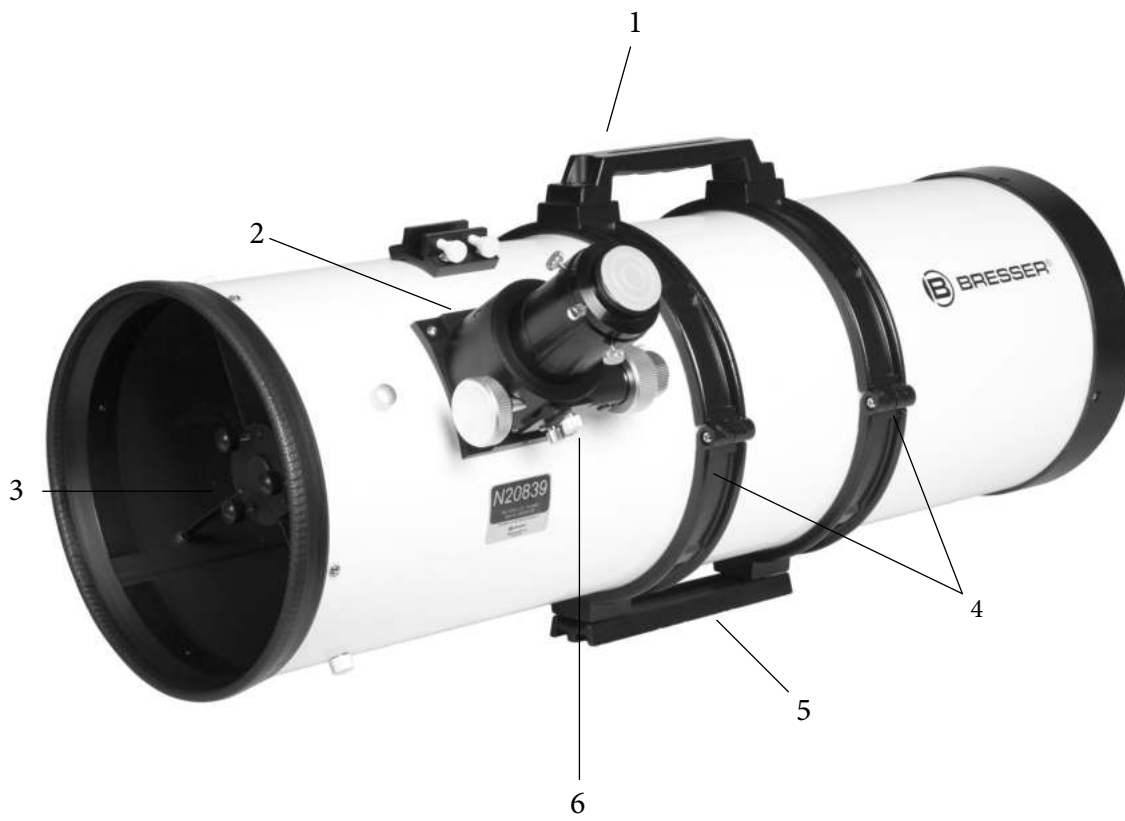
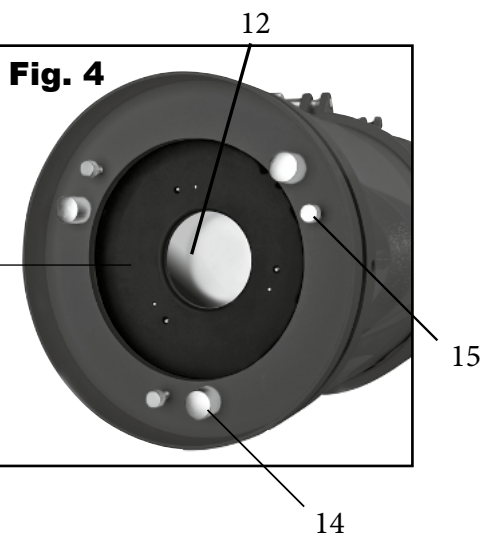
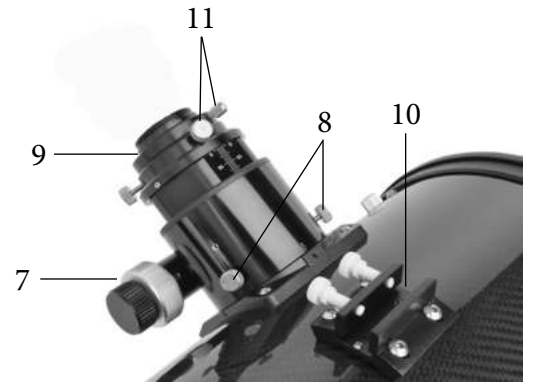

Fig. 3





Parts Overview

(Fig. 1)

- A Ocular Tube Assembly
- B Cradle with handle and 1/4 20 camera adapter
- C Vixen dovetail
- D Soft sided carry case

(Fig. 2)

1. Cradle
2. 2" Dual Speed Focuser
3. Secondary
4. Cradle
5. Vixen
6. Focuser tension and lock

(Fig. 3)

7. Course and fine focus
8. Focuser tension
9. 1.25" reducer with M42 .75 T Thread adapter
10. T Slot dovetail finder base
11. Tension collar locks

(Fig. 4)

12. Mirror Back
13. Mirror Frame
14. Collimation (3x)
15. Locking Screw (3x)

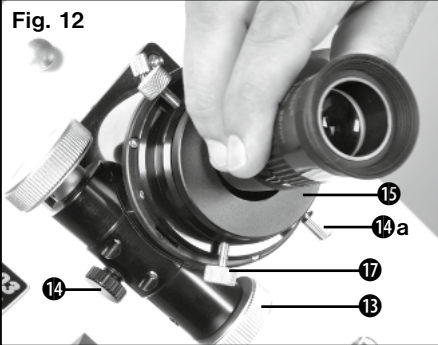

Fig. 12

Inserting the eyepiece (Fig. 12)

For visual observing the delivered focuser extension tube is always to be used.

1. Insert an eyepiece (Fig. 1, F) into the eyepiece holder (Fig. 12, 15).
2. Tighten the clamp screw (Fig. 12, 17) slightly.
3. Look through the eyepiece and turn the focusing wheel of the focusing drive (Fig. 12, 13) right or left to focus the image.
4. When using a 2" eyepiece remove the 1 1/4" eyepiece adapter (Fig. 12, 15) from the holder first.
5. Now insert a 2" eyepiece and fix it with the lock screw.

The eyepiece holder is equipped with a friction screw (Fig. 12, 14) on its bottom side and with two fixing screws (Fig. 12, 14a) on its top side. Adjust the friction screw so that the focusing drive can be moved sensitively. Additionally the focuser can be fixed with the fixing screws to avoid unintentional adjustment.

! NOTE!

Loosen the fixing screws on the focuser entirely before you start focusing! Never tighten the friction screw and fixing screws too firmly.

V

Use

Fig. 15



How To Align a View Finder (View Finder is not included)

1. Remove the dust protection caps from your telescope and finderscope tube.
2. Insert a lens with medium magnification in the lens mounting of the telescope itself.
3. Now look through the telescope lens at an object at least 800 m away.
4. Look through the view finder and loosen or tighten the scope adjustment screws until the cross hairs are exactly centered on the object you chose to look at through the telescope itself.
5. If it is unclear in the view finder turn the lens counter ring back a little to loosen the finder-scope lens mounting (7, fig. 1). Now turn the lens mounting (8, fig. 1) until it focuses and then tighten the counter ring again.

Your telescope is now ready for use.

Carry out alignment as above using a celestial object such as a bright star or the moon as well and then carry out any fine adjustment needed. Proceed as in step 6 above to do so.

Fig. 16



Mounting a camera

1. Remove the focuser extension tube from the focuser draw tube.
2. Install the included 2.0" eyepiece collar.
3. Install the included 1.25" eyepiece adapter with a T2-camera thread.
4. Connect your camera with the T2-camera thread. Any further adapter rings for your camera are optional.

Calculating the magnification

The magnification, or power of a telescope is determined by two factors: the focal length of the eyepiece and the focal length of the telescope.

Your telescope is supplied with one eyepiece. The focal length of the eyepiece, 26mm, is printed on its side.

The focal length of the 208/812 Photo Newton is 812mm.

To change magnification, change eyepieces.

To calculate the magnification of a given eyepiece, use this formula:

$$\text{Magnification} = \frac{\text{Telescope focal length}}{\text{Eyepiece focal length}}$$

Example with the 208/812 Photo Newton and a 26 mm eyepiece:

$$\text{Magnification} = \frac{812 \text{ mm}}{26 \text{ mm}} = 31x \text{ (approx. value)}$$

The type of eyepiece, whether Modified Achromatic, Plössl, or Super Plössl, has no effect on magnification, but does have a bearing on such optical characteristics as field of view, flatness of field, and color correction.

Maximum practical magnification is about 50X per inch of aperture (for the 8" it is 208 x 2 = approx. 400X magnification). Generally, however, lower powers produce higher image resolution. When unsteady air conditions prevail (as witnessed by rapid "twinkling" of the stars), extremely high powers result in distorted magnification and observational details are diminished by the use of excessive power.

When beginning observations on a particular object, always start with a low power eyepiece. Centered the object in the field of view. Sharply focus the object. Then try using a higher power eyepiece. If the image starts to become fuzzy when you use higher magnification, back down to a lower power. The atmosphere is not sufficiently steady to support high powers. Keep in mind that a bright, clearly resolved, but smaller image will show far more detail than a dimmer, poorly resolved larger image.

Observation

Allow for a temperature adjustment for about 90 minutes before starting an observation. Because when bringing the telescope e.g. from a heated car or house to a place outside so called tube seeing may occur. This means that the primary mirror is warmer than the air and will produce air turbulence.

After the temperature adjustment the telescope will produce a sharp image.

Try out your telescope during the daytime at first. It is easier to learn how it operates and how to observe when it is light.

Pick out an easy object to observe: A distant mountain, a lighthouse or something else. Point the optical tube so it lines up with the object.

Look through the LED viewfinder until you can see the object.

Once you have the object lined up in the finder, it should also be visible in the optical tube's 26 mm eyepiece.

Look through the eyepiece and start focusing on the object you have chosen.

When you feel comfortable with the finder, the eyepieces, the locks and the adjustment controls, you will be ready to try out the telescope at night. The Moon is the best object to observe the first time you go out at night. Pick a night when the Moon is a crescent. No shadows are seen during a full Moon, making it appear flat and uninteresting.

Use a neutral density filter (sometimes called a "moon filter") when observing the Moon. Neutral density filters are available from your local dealer as an optional accessory.

Spend several nights observing the Moon. Some nights, the Moon is so bright that it makes other objects in the sky difficult to see. These are nights that are excellent for lunar observation. The most obvious features are craters. The dark areas on the Moon are called maria and are composed of lava from the period when the Moon still had volcanic activity. You can also see mountain ranges and fault lines on the Moon.

Planets

During their orbit around the sun the planets are continuously changing their position on the sky. You can find the actual position of the planets in astronomy circulars and soon on the information center of the Explore Scientific homepage. The following planets are especially suited for observations with your telescope:

Venus

The diameter of Venus is about 9/10 the diameter of the Earth. When Venus is orbiting the sun the astronomer can observe the change of the light phases of Venus during this orbit: Crescent, half Venus, full Venus – very much like the phases of the moon. The planetary disc of Venus appears white because the sunlight is reflected by a compact layer of clouds that covers all surface details. Venus is only visible before dawn and shortly after dusk in the vicinity of the sun, so be careful not to look into the sun.

Mars

The diameter of Mars is about half the Earth's diameter. In a telescope Mars appears as a tiny red-orange disk. Maybe you will see a tiny white patch when you look at the polar regions that are covered in ice. About every two years, when Mars and Earth reach their smallest distance you can discover new features.

Jupiter

The biggest planet in our solar system is Jupiter with about 11 times bigger equatorial diameter than the Earth. The Planet appears as a disk that is covered in dark lines. Those lines are cloud bands in the atmosphere of Jupiter. Even with low magnification 4 of the 67 moons of Jupiter are visible – the so called Galilean moons (Io, Ganymed, Europa and Callisto). Because those moons are orbiting Jupiter the visible number and position changes. Sometimes a moon passes above the planetary disc of Jupiter – then the shadow of the moon can be spotted on the planet as a sharp dark spot.

Saturn

Saturn has a diameter about 9 times the Earth's diameter and appears as small roundish disc. You can see the rings of Saturn on both sides of the planetary disc. Galilei, who was the first



Fig. 17: Craters of the moon are excellent targets to observe even for beginners.



Fig. 18: Planet Venus in its thin crescent phase

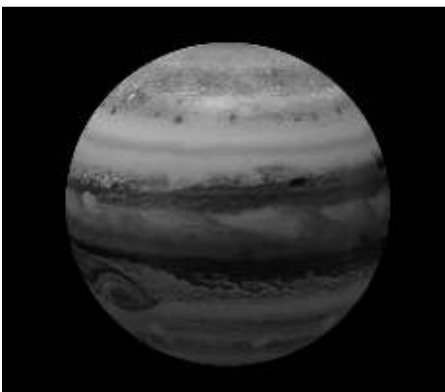

Fig. 19: Jupiter's four largest moons can be observed in a different position every night.

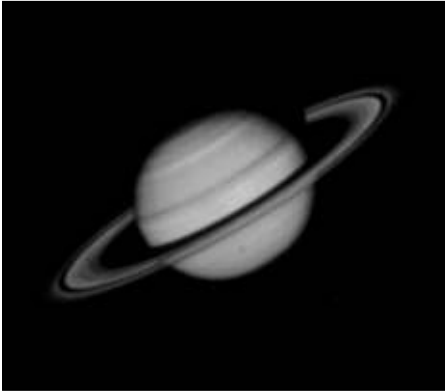

Fig. 20: Saturn is perhaps the most unforgettable sight to see in a telescope.

human observer of this planet in 1610 couldn't know that the planet had rings – he described that Saturn had "ears". The rings of Saturn mainly consist of billions of icy particles – from tiniest dust up to the size of a house. The biggest division in the rings, the so called "Cassini division" should be easily seen with your telescope in nights of steady air. The biggest of the 62 moons of Saturn, Titan, is also visible as a bright, star like object in the vicinity of the planet. Up to 6 moons can be detected in your telescope.

Deep-Sky-Objects

To locate constellations, stars or "deep-sky-objects", it makes sense to use a star chart. We will list a selection of deep sky objects here:

Stars are giant objects that mainly consist of gas. Due to the nuclear fusion in their core they radiate energy and shine. The stars are extremely far away. Because of this vast distance they appear as tiny spots of light in your telescope, despite their size – no matter how big your telescope is.

Nebulae are giant interstellar clouds of gas and dust. Within those clouds new stars are born. The premier nebula on the northern hemisphere is the Great Orion Nebula, a diffuse nebula that looks like a fuzzy patch of light. M42 is 1600 light years away from Earth.

An open cluster is a group of young stars that were born in a single diffuse nebula not too long ago (on an astronomical time scale...). The Plejades are an open cluster in a distance of about 410 light years. You can see several hundred stars in the telescope.

Constellations are big patterns of stars that were believed to be celestial representations of men, gods and objects by the old civilizations. Those patterns are too big to be observed at a single glance through a telescope. If you want to become familiar with the constellations, start with a pattern that is easy to find, like the Big Dipper in the constellation Ursa Major. Try to locate the other constellations in the neighborhood of this constellation in the second step and move on to even more distant patterns.



Fig. 21: M31, the Andromeda galaxy, is one of the easiest galaxies to locate and observe during the fall and winter evenings.

Galaxies are gigantic accumulations of stars, nebulae and clusters that are held together by gravity. Most galaxies have a spiral shape (like for example our own galaxy, the Milky Way), but there are also galaxies with elliptical or irregular shapes. The closest spiral galaxy is the Andromeda Galaxy (M31). The core of M31 looks like a bright patch of light in your telescope – under dark clear skies you will be able to detect features in this object with your telescope.

When you become an advanced observer you can look for other types of objects such as asteroids, planetary nebula and globular clusters. And if you're lucky, every so often a bright comet appears in the sky, presenting an unforgettable sight.

The more you learn about objects in the sky, the more you will learn to appreciate the sights you see in your telescope. Start a notebook and write down the observations you make each night. Note the time and the date.

One of the best methods to record your telescopic views is astronomical sketching. It improves your ability to see fine detail and subtle variations in brightness.

Many astronomical magazines and online forms give the opportunity to get in contact with other amateur astronomers.

Online resources like www.cloudynights.com or www.stargazerslounge.com help to build up knowledge and get to know other aspects of the hobby. The more you know about it, the more fun this hobby will be!



Fig. 22: The Pleiades is probably the most striking star cluster to observe in the Northern Hemisphere.

Useful tips

By the way, you might have noticed something strange when you looked through your eyepiece. The image is upside down, and it is also reversed. That means reading words can be a problem or viewing objects on the ground can be a problem. But it has no affect on astronomical objects.

Because of the Earth's rotation all objects seem to drift across the field of view. To compensate this movement you have to move the telescope smoothly and slowly. The higher the magnification the more accurate this tracking movement has to be.

Another solution is to place the object on the eastern rim of the field of view and let it drift across the field, then reposition it on the eastern rim again. However – this method only works with good eyepieces that are delivering a sharp image up to the edge of the field.

Vibrations: Try to avoid touching the eyepiece during observations. Touching the eyepiece and the slight shiver of the hand will cause unsteady views.

Dark adaption: Give your eyes some time to adapt to the darkness. This takes about 20-30 minutes after an exposure to a bright light – even if it is a short exposure. Use a dim light with a red filter to read star charts or draw objects – dim red light does not influence the dark adaption very much.

Observations through a window are very disadvantageous (even if the window is open). The light that is gathered by the telescope has to pass a lot of air and glass layers, causing severe image deterioration.

Planets and other objects that are close to the horizon are severely influenced by air turbulence and absorbance. It is much better to time your observations in a way that those objects are close to the meridian, so that they are on their highest position possible. If the image is dim or moving fast, use a smaller magnification. Using too much magnification is a mistake that is made very often by beginners.

Warm clothing: Even in the summer the nights may get very cold during clear nights, especially on the mountains. Always remember to bring warm clothing like thick jackets, beanies, gloves, winter shoes and thick socks – even if your were sweating during the day. It is hard to enjoy even the best night when you are freezing!

Explore your observing site during the day: The ideal site should be far of frequently used streets and other light sources that would prevent your eyes to become dark adapted. Keep in mind that it is likely to get foggy in the vicinity of open water, such as river valleys or lakes. The ground should be solid and relatively flat. You can observe in the city, but try to get to a place some distance away, where you can see the milky way if possible. You can get really good conditions as close as 30mi outside of cities. An old astronomers quote says: “ you cannot really replace a dark sky by anything than a darker sky”

Additional information:

As mentioned before, a lot of additional information for people of all ages can be found in the internet and in specialist magazines. Most public libraries normally offer good literature. You may also contact an astronomical organization next to you. Events are often announced in the local press.

Maintenance

Your telescope is a precision instrument that will provide many years of fun. When you are treating this telescope with the same care as for example an expensive camera, it is very unlikely that you will ever need to return it for service or maintenance. Please notice the following rules:

1. Avoid cleaning the optics. A little dust on the optical system will not deteriorate the performance of the optical system by any noticeable amount. A little dust should not be a reason to clean the optics.
2. If cleaning the optics is necessary it is best to brush away the dust with a fine camel hair brush as it is used for photographic equipment. NEVER USE pressurized air or microfiber cloth as it is often recommended for glasses.
3. Organic dirt (fingerprints etc.) can be removed from the optical surface with a mixture of 3 parts distilled water and one part isopropanol. You may add a very little bit of glass cleaner to the mix. Only use soft, white cosmetic tissues. Soak the mirror to dissolve the dirt and remove the fluid with short, cautious strokes. Remember to change tissues every few strokes.

Attention: Never use any pre-impregnated cleaning cloths!

4. While you are using your telescope during the night you will eventually have dew condensing on the surfaces. This will not cause any trouble – your telescope is designed to take a little moisture without problems. When you store the telescope, however, we recommend to wipe the surfaces (except the optics) with a dry cloth and give the telescope some time to evaporate the water on the optics by putting the telescope into a dry room with the lid of the mirror box open. Wait until all water has dried off until you store the telescope.
5. If your telescope is not to be used for an extended period, perhaps for one month or more, it is advisable to remove the batteries from the battery pack. Batteries left in the telescope for prolonged periods may leak, causing damage.
6. Do not leave your telescope inside a sealed car on a warm summer day; excessive ambient temperatures can damage the telescope's internal lubrication.

Collimation

All telescopes are collimated precisely at the factory before shipment. However – a telescope that was disassembled has to be freshly collimated after reassembly. Collimating a telescope is a straightforward procedure that is not very difficult. The collimation procedure is slightly

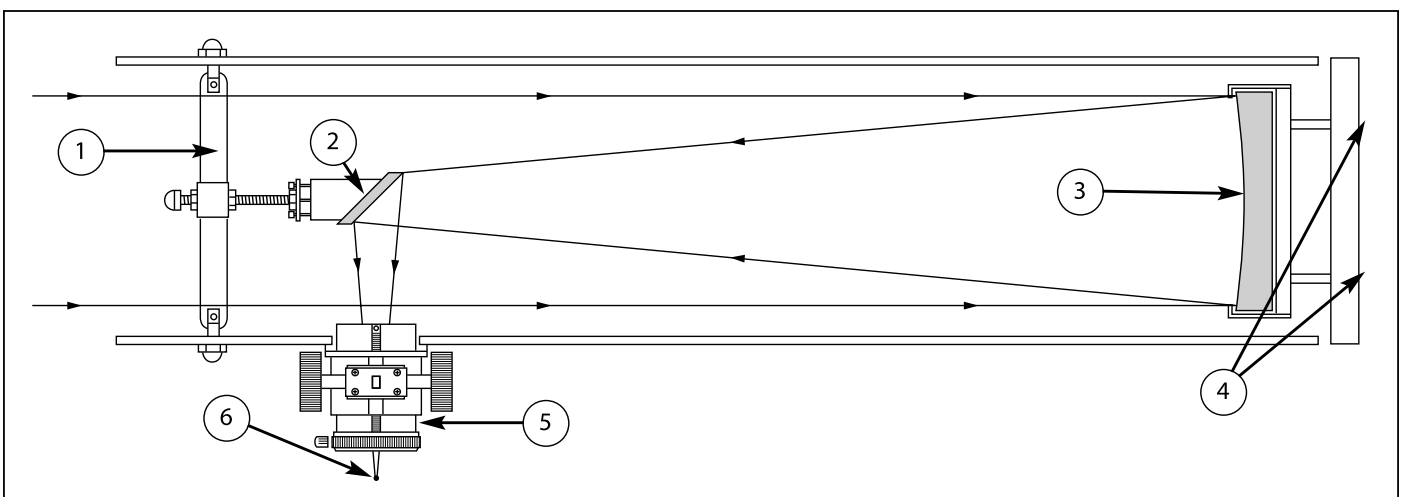

Fig. 23: Newtonian reflecting telescope. Spider vanes (1); secondary mirror (2); parabolic primary mirror (3); primary mirror adjustment screws (4); focuser drawtube (5); focused image (6).

different from that of other Newtonian reflecting telescopes, because of the "fast" f/5 to f/6 focal ratio of the primary mirror. In typical Newtonian reflectors with more conventional focal ratios (i.e. longer focal ratios), when the observer looks down the focuser tube (without an eyepiece in the focuser), the images of the diagonal mirror, primary mirror, focuser tube and the observer's eye appear centered relative to each other.

However, with the short focal ratio primary mirror of this Newtonian telescope, correct collimation requires that the diagonal mirror be offset in 2 directions: (1) away from the focuser and (2) towards the primary mirror, in equal amounts. This offset is approximately 1/8" in each

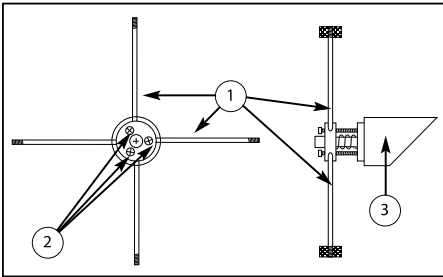

Fig. 24: Secondary Mirror Assembly (front and side view). Spider vanes (1); tilt screws (2); secondary mirror holder (3).

direction. Note that these offsets have been performed at the factory prior to shipment of your telescope. It is only necessary for you to confirm that the telescope has not been badly jarred out of collimation, and to perform the final fine-tuning of Step 4, below. To check and, if necessary, set the optical collimation, follow these steps:

1. Observe through the focuser and orient your body so that the telescope's primary mirror is to your right, and the open end of the telescope tube is to your left. The diagonal mirror will appear centered and round as shown (Fig. 26). If the diagonal appears off center, then adjust the 3 collimation screws on the plastic diagonal mirror housing.
2. If the reflection of the primary mirror (Fig. 26) is not centered on the surface of the diagonal mirror, adjust the 3 collimation adjustment screws on the diagonal mirror housing to center the reflection. As described above, the 3 collimation screws (Fig. 24, 2) on the diagonal mirror housing are used for two different adjustments during the collimation procedure.

! NOTE!

Do not force the 3 screws (Fig. 24, 2) past their normal travel.

Do not rotate the collimation screws more than two full turns in a counterclockwise direction (i.e. not more than two full turns in their "loosening" direction), or else the diagonal mirror may become loosened from its support. Note that the diagonal mirror collimation adjustments are very sensitive: generally turning a collimation screw 1/2-turn will have a dramatic effect on collimation.

3. If the reflection of the diagonal mirror is not centered within the reflection of the primary mirror, adjust the 3 collimation adjustment screws located on the rear of the primary mirror cell.

! NOTE!

The primary mirror housing (Fig. 25) is equipped with 6 screws. The 3 large knurled screws are collimation screws (Fig. 25, 21) and the 3 smaller knurled screws are lock screws (Fig. 25, 20). These lock screws must be loosened before the collimation screws can be turned. Proceed by "trial and error" until you develop a feel for which collimation screw to turn in order to change the image in any given way.

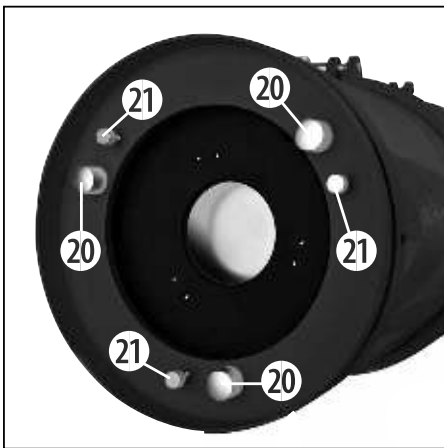

Fig. 25: Underside of rear mirror tube (primary mirror housing). Collimation screws (20); Lock screws (21).

4. Perform an actual star test to confirm the accuracy of steps 1 through 3. Using the 25mm eyepiece, point the telescope at a moderately bright (second or third magnitude) star, and center the image in the main telescope's field of view.
5. Bring the star's image slowly in and out of focus until you see several disks surrounding the star's center. If steps 1 through 3 were done correctly, you will see concentric (centered with respect to each other) circles (Fig. 27, 1). An improperly collimated instrument will reveal oblong or elongated circles (Fig. 27, 2). Adjust the 3 collimating screws on the primary mirror housing until the circles are concentric on either side of the focus.

In summary, the adjustment screws on the plastic diagonal mirror housing change the tilt of the secondary mirror so that it is correctly centered in the focuser drawtube, and so that the primary mirror appears centered when looking into the focuser. The 3 collimating knobs on the primary mirror change the tilt of the primary mirror so that it reflects the light directly up the center of the drawtube.

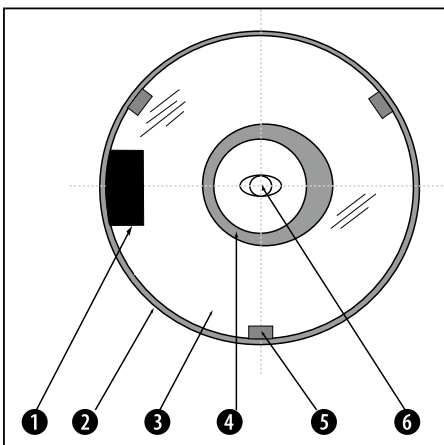

Fig. 26: View you see while collimating the telescope (without eyepiece inserted). Focuser drawtube (1); diagonal mirror (2); reflection of primary mirror (3); reflection of secondary mirror (darkened due to back lighting) (4); primary mirror holder (5); reflection of observer's eye (6)

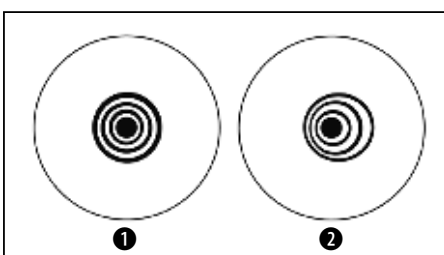

Fig. 27: Correct (1) and incorrect (2) collimation as viewed during a star test.

Technical data**EXPLORE SCIENTIFIC**

PN 208/812 Photo Newton

Tube

Metal-tube with adjustable clips, universal dovetail adapter and handle.

four armed, steel

Secondary mirror holder

8" (208 mm), parabolic

Primary mirror Secondary

85 mm

mirror Focal length

812 mm

Aperture ration

f/3.9

Theoretical resolving power

0,74 arc seconds

Limiting magnitudes

13.5 mag

Focuser

Duel Speed 2" Focuser with 1 1/4" T2-adapter

Tube weight (N208CF)

18.3 lbs

Tube weight (BR-20839)

22 lbs

VII

· Disposal ·



Dispose of the packaging materials properly, according to their type, such as paper or cardboard. Please take the current legal regulations into account when disposing of your device. You can get more information on the proper disposal from your local waste-disposal service or environmental authority.



· Warranty and Service ·

LIMITED WARRANTY AND EXPLORE STAR WARRANTY

Explore Scientific warrants your product to be free from defects in materials and workmanship. Explore Scientific will repair or replace such product or part thereof which, upon inspection by Explore Scientific, is found to be defective in materials or workmanship. As a condition to the obligation of Explore Scientific to repair or replace such product, the product must be returned to Explore Scientific together with proof-of-purchase or product registration satisfactory to Explore Scientific. Explore Scientific products offer a Limited Warranty for 1 year, however, once registered, EXPLORE SCIENTIFIC branded products are under warranty forever as long as the product is registered within 60 days. This warranty is also transferrable from original owner to new owner as long as the product is properly transferred via registration page. Original owner may include person receiving brand new product as a gift. Warranty Periods

Explore Scientific Branded Telescopes: Limited* USA One Year Warranty, Extendable to Unlimited Lifetime Warranty

Explore Scientific Branded Eyepieces: Limited* USA One Year Warranty, Extendable to Unlimited Lifetime Warranty

Explore Scientific Branded Non-Electronic Telescope Accessories: Limited* USA One Year Warranty, Extendable to Unlimited Lifetime Warranty

* Limited Warranty is in the USA and its territories, extended to our Transferable Unlimited Lifetime Warranty when product is registered on the available Explore Scientific Branded Products. Warranties listed below apply to the following Branded Products: Explore One, Bresser, National Geographic, EduScience

www.explorescientificusa.com

EXPLORE[®]
SCIENTIFIC

1010 S 48th Street
Springdale, AR 72762