

aim telescope

mtel-50

Instruction Manual



SPECIFICATIONS

Focal length: 350 mm

Diameter of Objective Lens: 50 mm

Eyepieces: K-9, K-20

Accessories: 2x Barlow Lens, 45° Corner Lens, Table Top Tripod

mtel-50 Instruction Manual

v

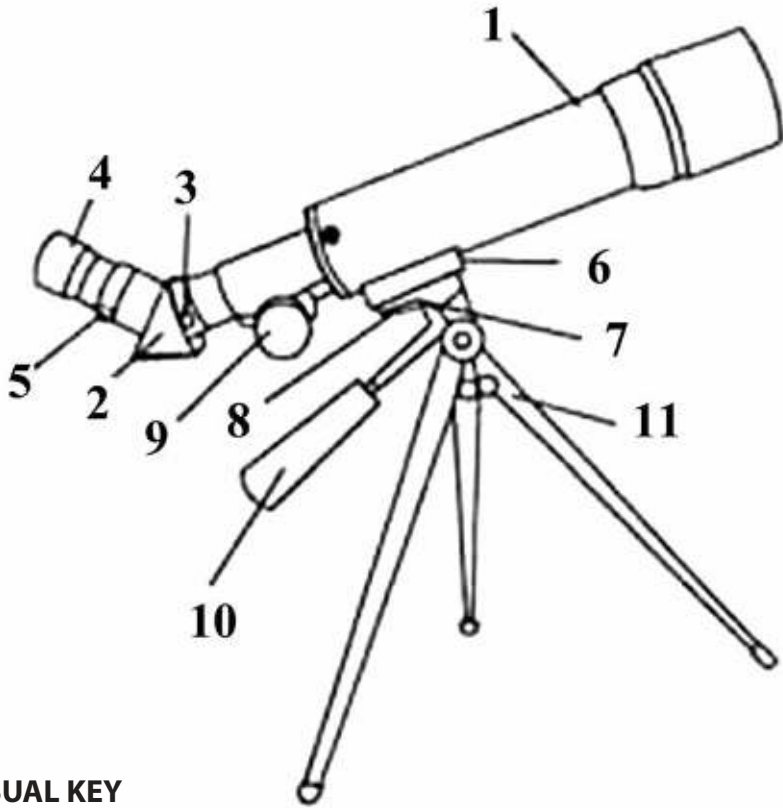

VISUAL KEY

1. Main Tube
2. Diagonal Prism
3. Diagonal Prism Holding Screw
4. Eyepiece Lens
5. Eyepiece Holding Screw
6. Tripod Holder
7. Tripod Platform
8. Tripod Securing Screw
9. Focus Wheel
10. Mount Adjustment Handle
11. Tripod Leg

mtel-50 Instruction Manual

ASSEMBLY

Take the tripod out of the pouch and extend the legs (11).
Put the tripod holder (6) of the main tube (1) on to the tripod platform (7) and tighten it together with the tripod securing screw (8), make sure the tube is placed in the right direction as shown in the diagram.
Take the tripod out of the pouch and extend the legs (11).
Put the tripod holder (6) of the main tube (1) on to the tripod platform (7) and tighten it together with the tripod securing screw (8), make sure the tube is placed in the right direction as shown in the diagram.

Place the diagonal prism (2) to the tube (use the chrome end) and tighten with the holding screw (3). Place the eyepiece with the lowest magnification (K-20) into the prism and tighten the screw (5). Loosen the mount adjustment handle to adjust the direction where you want to focus, then adjust the focus wheel (9) to get a clear and sharp view.

MAGNIFICATION

Changing the eyepiece will change the power or magnification (see the EYEPIECE CHART ON NEXT PAGE).
Focus re-adjustment may be required.

USE 2x BARLOW

Using the 2x Barlow will double the magnification or power. The Barlow is placed between the telescope and the eyepiece.
Please note that the Barlow lens can not be used in conjunction with the diagonal prism. (see diagram below)

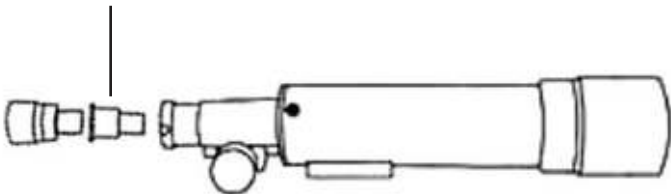

mtel-50 Instruction Manual

EYEPIECE CHART AND THEORETICAL POWER LIMITS

Eyepiece	Power	Power with 2x Barlow
K-20	18x	36x
K-9	40x	80x

HOW TO CARE FOR YOUR TELESCOPE

Always keep your eyepiece lens in the pouch. Use lens cloth or soft and lintless cloth when cleaning or wiping the lenses. Never attempt to clean the telescope internally or take it apart.

Avoid sudden temperature fluctuations likely to cause any dampness in the air to condense on the telescope's lens. If this phenomenon occurs, place the lens at a moderate distance away from a heat source and let the dampness evaporate away progressively.

Warning: To avoid any eye injury never look directly into another optical instrument through the telescope and never observe the sun with unprotected eyes!

This product is designed and intended for ages 13 years and older.

CARSON®

Carson | 2070 5th Avenue | Ronkonkoma, New York 11779
Phone 631-963-5000 | Fax 631-427-6749

For information, call toll-free: 1-800-967-8427

info@carson.com | sales@carson.com | www.carson.com
www.carson.com