

ATHLON
RIDICULOUSLY GOOD OPTICS

CRONUS G2 UHD 7-42x60 TACTICAL

SPOTTING SCOPE
USER MANUAL &
CARE INSTRUCTIONS



athlonoptics.com

Congratulations on purchasing an Athlon spotting scope. Athlon is the ancient Greek word for "Prize" or "Medal." We think with the purchase of your Athlon product you have won the best "prize" on the market today. Great Quality while still being a great value.

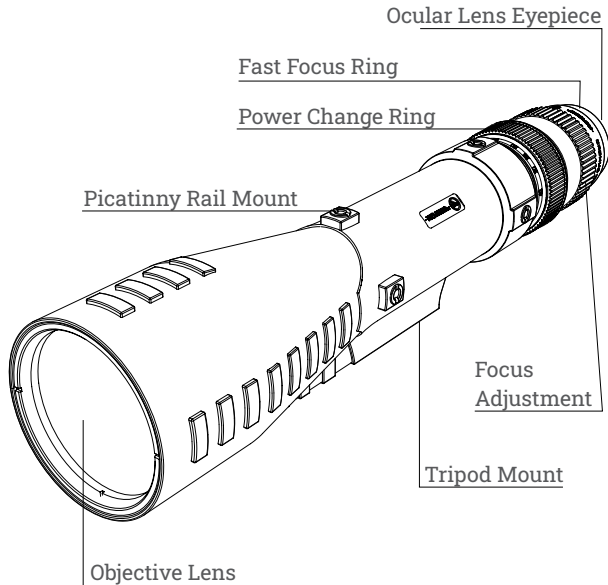

1. HOW TO USE THE ATHLON SPOTTING SCOPE

MOUNT THE ATHLON SPOTTING SCOPE

Attach the Athlon scope to a tripod or car window mount for steady viewing. Simply secure the tripod mount foot on a quick-release plate or mounting plate of the tripod head. The tripod mount has a standard $\frac{1}{4}$ -20 female thread.

ADJUST THE EYECUP

The adjustable eyecup on the Athlon spotting scope twists up and down so you can observe the full field of view if you wear eyeglasses or sunglasses. Fully extend the eyecup for best viewing without glasses. Twist to the down position for best viewing with glasses.

FAST FOCUSING THE RETICLE

The purpose of the Fast Focus eyepiece is to focus the reticle in the scope to your eyes. For a fast focus eyepiece, just simply rotate the fast focus ring at the end of the eyepiece in either direction to get a perfectly clear reticle while looking through the scope pointing at a flat, plain surface.

FOCUSING

You now are ready to adjust the focus of your Athlon spotting scope.

Your Cronus G2 UHD 7-42x60 Tactical Spotting Scope features a focus adjustment on the ocular side.

To focus your scope turn the focus ring until the image is clear.

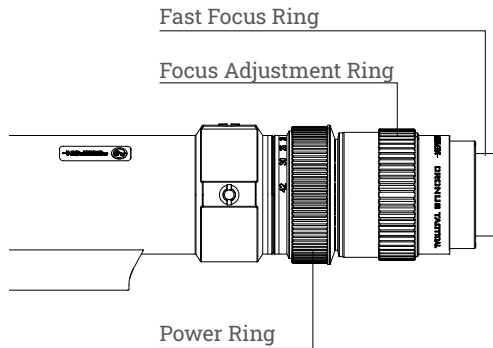

ADJUST THE MAGNIFICATION

The variable power zoom eyepiece provides multiple power settings. To change the magnification grasp the eyepiece body and rotate the Power Change Ring to the desired power.

As you zoom from low power to high power under low light conditions, you may notice a decrease in the image brightness. This is normal. As magnification is increased, the amount of light transmitted to your eye is decreased proportionately.

SUNSHADE USE

If the sun happens to be in a position in front of you, please screw-on a sunshade on to effectively block out stray light. The sunshade also shields the objective lens from mechanical damage and guards against soiling by fingerprints and precipitation.

CARE AND HANDLING TIPS

Do not try to disassemble and clean internally as this will void the warranty. If the scope requires repairs, please refer to the warranty section for complete instructions.

The external optical surfaces should occasionally be wiped clean. Use the lens cloth provided or an optical quality lens paper to wipe out dust or dirt on the external lens surface.

If large sand particles or heavy dirt contamination is observed, remove using soft brush or by blowing them away. Apply lens cleaning liquid before wiping off.

Always keep the protective lens covers in place when the scope is not in use to avoid dust collecting on the surface of the lenses. Store the unit in a low-humidity environment.

Note: **Never use facial tissue, heavy cotton, or flannel fabric—these materials can scratch the surface of a lens. Use lens cleaning fluid and an optical tissue or cloth to clean lenses.*

NEVER LOOK DIRECTLY AT THE SUN WITH YOUR SPOTTING SCOPE. THIS MAY CAUSE SERIOUS DAMAGE TO YOUR EYES

2. USE THE RETICLE

THE ATHLON® TSSR FFP MIL RETICLE

TSSR FFP MIL reticle is designed for tactical spotting scope for all types of ranging applications. The MIL based reticle has 0.2 MIL hash marks from the center extended into three directions. The “T” shape reticle with the horizontal base line 1 MIL below the center of the field of view will not block the spotter’s view over his or her target. With the reticle in first focal plane it shrinks into a simple cross-hair at low power for locating a target quickly and grows into a complex ranging system at high power for accurate ranging

and capturing enough details of the target. The unique design of quick ranging cross-hairs (12 inches above, 6 inches cross, 18 inches below) help you to range your shooting target from 300 yards to 1000 yards at a blink of your eyes. The 72 inch span from the top of the cross to the foot mark at the bottom gives you a quick reading of a standard human body at different distances. The 0.1 MIL hash mark between 5th MIL and the 6th MIL provides the finest measurement when you need that level of details.

Application: *All Range*

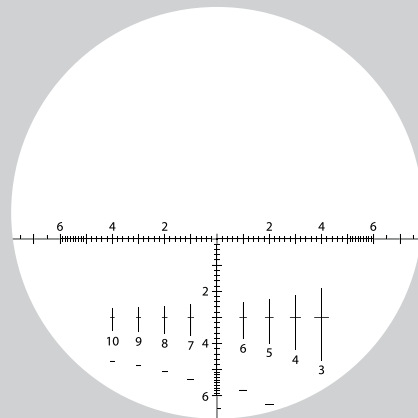

Note: *The reticle image shown above may appear differently among different models due to different magnification and location of the reticle.*

RETICLE SUBTENSIONS

The TSSR FFP MIL reticle is based on the milliradian, usually shortened to mrad or mil. A “mil” is defined as “one thousandth”, or 1/1000. A mil is 1/1000 of a radian (a unit of angular measurement). Since there are 6.2832 radians in a circle, and each radian is chopped up into a thousand pieces, there are $6.2832 \times 1000 = 6,283.2$ mils in a circle. Since there are 360 degree in a circle, we can get $360 \text{ degree} / 6,283.2 \text{ mils} = 0.0573 \text{ degree/mil}$. If the target is 100 yards (3600 inches) away, we can use $3600 \text{ Tan } (.0573 \text{ degree})$ to get 3.6 inches which means 1mil equals to 3.6 inches at 100 yards

The TSSR FFP MIL reticle is located at the focal plane in the front of the erector tube which is a key part of achieving variable power inside the spotting scope. Size of the first focal plane reticle grows or shrinks at the same ratio with the changing size of the image of your target when you try to zoom in or zoom out. Since the size of the reticle remains constant compared to your target regardless of the magnification, the first focal plane reticle provides accurate ranging capability at all power settings, and finer details of the reticle at high power for a spotter to gauge a target with a higher level of accuracy and confidence.

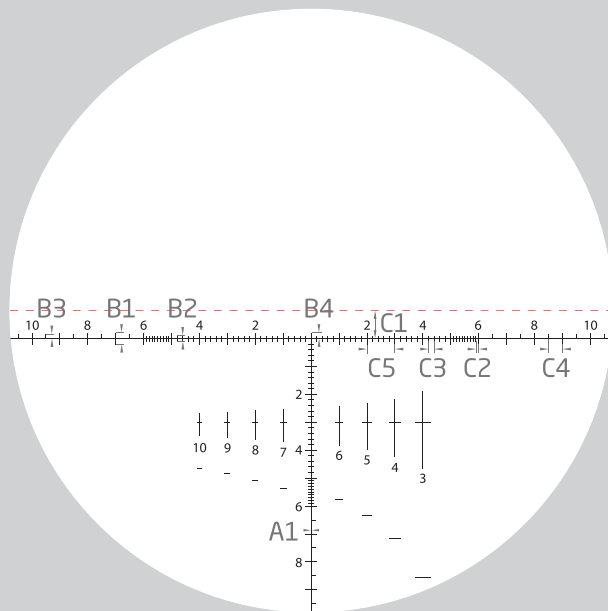

UNIT	A1	B1	B2	B3	B4	C1	C2	C3	C4	C5
MIL	0.028	0.4	0.2	0.15	0.2	1	0.1	0.2	0.5	1
in @ 1000 yds	0.1	1.44	0.72	0.54	0.72	3.6	0.36	0.72	1.8	3.6

NOTE: The reticle is 1 MIL below the virtual center line

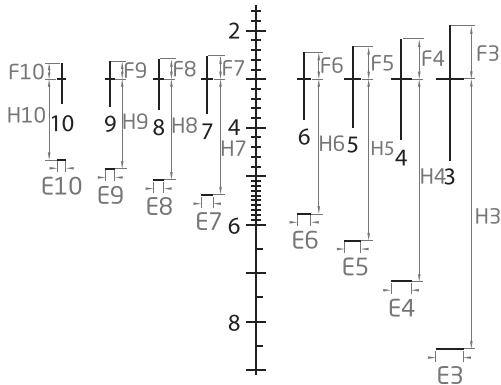
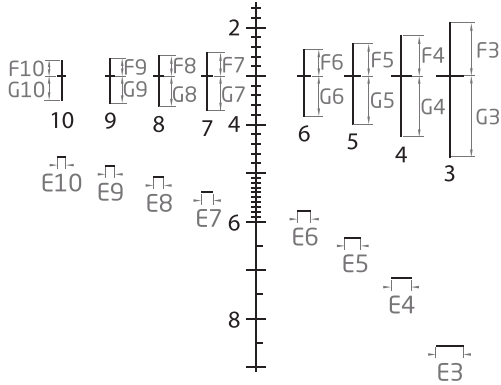

E = 6 inches

UNIT	E3	E4	E5	E6	E7	E8	E9	E10
MIL	0.56	0.42	0.33	0.28	0.24	0.21	0.19	0.17
distance in yds	300	400	500	600	700	800	900	1000

* if a quick ranging guide E6 fits a 6 inch wide target the distance is 600 yards

F = 12 inches

UNIT	F3	F4	F5	F6	F7	F8	F9	F10
MIL	1.11	0.83	0.67	0.56	0.48	0.42	0.37	0.33
distance in yds	300	400	500	600	700	800	900	1000

* if a quick ranging guide F4 fits a 12 inch tall target the distance is 400 yards

G = 18 inches

UNIT	G3	G4	G5	G6	G7	G8	G9	G10
MIL	1.67	1.25	1	0.83	0.71	0.63	0.56	0.5
distance in yds	300	400	500	600	700	800	900	1000

* if a quick ranging guide G8 fits an 18 inch tall target the distance is 800 yards

H = 60 inches

UNIT	H3	H4	H5	H6	H7	H8	H9	H10
MIL	5.56	4.17	3.33	2.78	2.38	2.08	1.85	1.67
distance in yds	300	400	500	600	700	800	900	1000

* if a quick ranging guide H7 fits a 60 inch tall target the distance is 700 yards

NOTE: The crosses and the foot marks (see page 12) with numbers between them are the quick ranging guides. Those guides are uniquely calibrated so they represent the same dimensions at different distances. The number below the cross represents the yardage in hundreds. You can simply fit check the guides against a known size target. Once you identified a fit just read out the number below the cross in hundred yards, which are the distances between you and the target

DISTANCE RANGING

Equations for ranging distance to a target using mils.

$$\frac{\text{Height of Target (Yards)} \times 1000}{\text{MIL Reading on Reticle}} = \text{Distance to Target (Yards)}$$

$$\frac{\text{Height of Target (Meters)} \times 1000}{\text{MIL Reading on Reticle}} = \text{Distance to Target (Meters)}$$

$$\frac{\text{Height of Target (Inches)} \times 27.8}{\text{MIL Reading on Reticle}} = \text{Distance to Target (Yards)}$$

Because the actual or at least closest estimate of the height of your target is the key part of above equations, you have to know the height of your target or heights of other objects nearby your target that are known to you.

As you can see the actual reading of your target is another key variable in those equations, you want to put your spotting scope on a steady rest or tripod as much as possible so you could get an accurate reading. If needed using the smallest measurement on the reticle to get the most accurate readings.

EXAMPLE 1

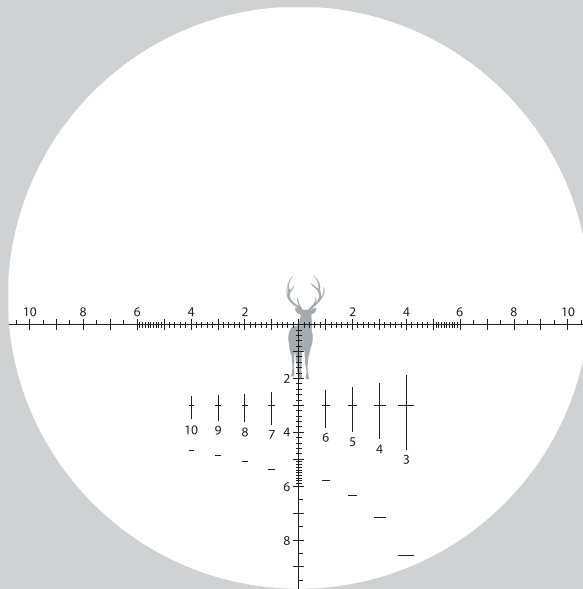

Reading a 5-foot target (1.667 yard) at 2 mils gives 833.5 yards

$$\frac{1.667 \text{ yards} \times 1000}{2 \text{ mils}} = 833.5 \text{ yards}$$

EXAMPLE 2

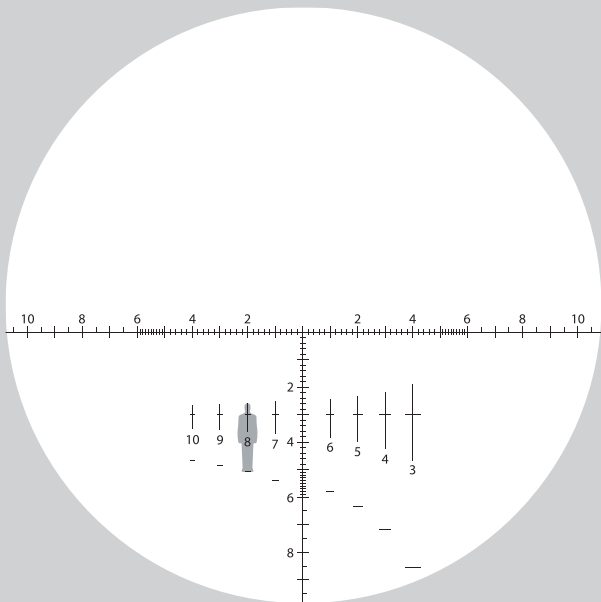

The distance between the top of the cross and the foot mark of any ranging guide is 72 inches. If you can fit a 72 inches tall target into the quick ranging guide, just read out the numbers under that guide in hundred yards. In this example the distance to the target is 800 yards

EXAMPLE 3

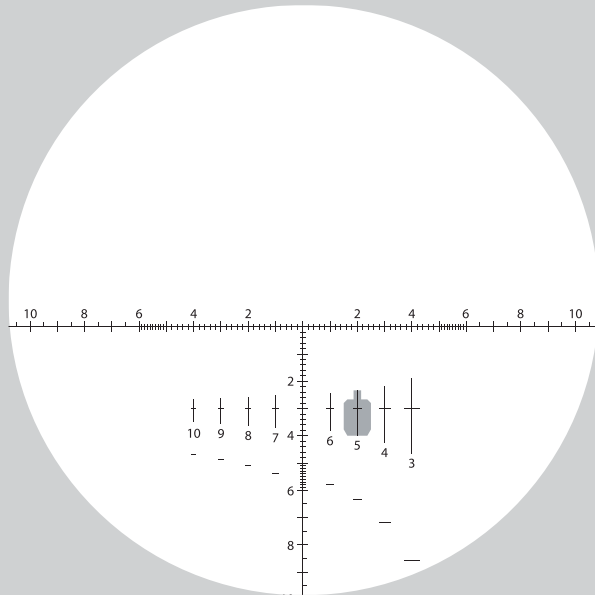

The height of the cross of the ranging guides is 30 inches. If you can fit a 30 inches tall target into any cross just read out the number under that particular cross. In this example the distance to the target is 500 yards.

THE ATHLON GOLD MEDAL LIFETIME WARRANTY*

Demand the most from your equipment. When things go unexpectedly or accidents happen, rest assured, Athlon Optics carry a lifetime transferable warranty. Athlon guarantees to repair or replace your product if damaged through normal use. No charge; No receipt; No Registration required.

**This warranty does not cover damages caused by deliberate damage, misuse, theft or maintenance provided by someone other than the Athlon Authorized Service Department.*



ATHLON
RIDICULOUSLY GOOD OPTICS

CRONUS G2 UHD 7-42x60 TACTICAL

MANUEL DE
L'UTILISATEUR ET
CONSIGNES D'ENTRETIEN



Félicitations pour votre achat d'une lunette d'observation Athlon. Athlon vient du grec ancien et signifie «Prix» ou «Médaille». Nous pensons qu'avec l'achat de votre Athlon vous avez obtenu le meilleur «prix» sur le marché aujourd'hui. Une excellente qualité à un excellent prix

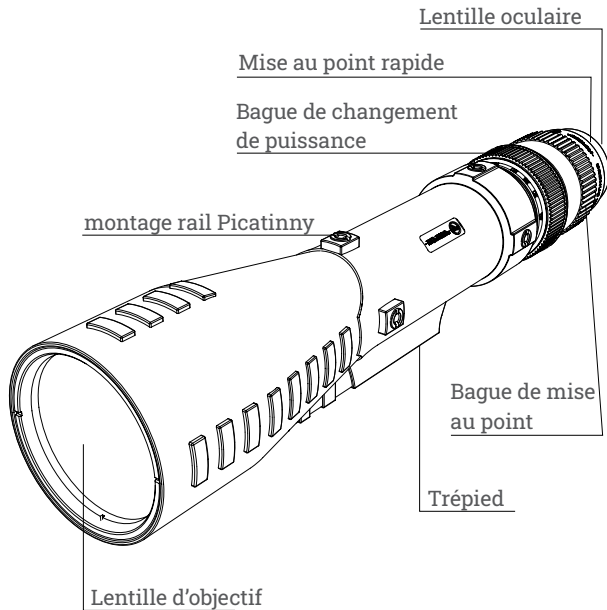

COMMENT UTILISER LA LUNETTE D'OBSERVATION ATHLON

MONTER LA LUNETTE D'OBSERVATION ATHLON

Fixez la lunette Athlon à un trépied ou à un support de fenêtre de voiture pour une vision stable. Fixez simplement le pied de montage du trépied sur une plaque à dégagement rapide ou une plaque de montage de la tête du trépied. Le support de trépied a un filetage femelle standard ¼-20.

RÉGLEZ L'OEILLETON DE LA LUNETTE

L'oeilleton réglable sur la lunette d'observation Athlon se tord de haut en bas pour vous permettre d'observer l'ensemble du champ de vision si vous portez des verres ou des lunettes de soleil. Étendez complètement l'oeilleton pour une vision optimale sans lunettes. Tordez vers le bas pour une vision optimale avec des lunettes.

MISE AU POINT RAPIDE DU RÉTICULE

Le but de l'oculaire Fast Focus est de focaliser le réticule de la lunette sur vos yeux. Pour un oculaire à mise au point rapide, tournez simplement la bague de mise au point dans les deux sens pour obtenir un réticule parfaitement clair tout en regardant à travers la lunette pointant vers une surface plane et plane.

MISE AU POINT

Vous êtes maintenant prêt à ajuster la mise au point de votre lunette d'observation Athlon.

Votre longue-vue tactique Cronus G2 UHD 7-42x60 dispose d'un réglage de la mise au point du côté oculaire.

Pour mettre au point votre lunette, tournez la bague de mise au point jusqu'à ce que l'image soit nette.

RÉGLAGE DE L'AGRANDISSEMENT

L'oculaire à puissance d'agrandissement réglable offre plusieurs réglages de puissance.

Pour modifier l'agrandissement, saisissez le corps de l'oculaire et tournez la bague de réglage de la puissance à la valeur souhaitée.

Vous pourrez expérimenter une diminution de la clarté

de l'image lorsque vous effectuez un agrandissement dans des conditions de faible éclairage. Ceci est normal. La quantité de lumière transmise à votre oeil diminue proportionnellement à mesure que vous zoomez.

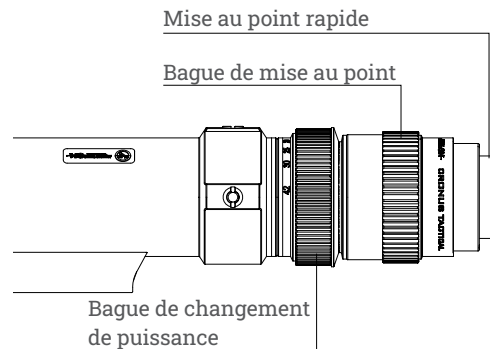

UTILISER UN PARE-SOLEIL

Si le soleil se trouve devant vous, veuillez visser un pare-soleil pour bloquer efficacement la lumière parasite. Le pare-soleil protège également la lentille de l'objectif contre les dommages mécaniques et protège contre les salissures causées par les empreintes digitales et les précipitations.

CONSEILS D'ENTRETIEN ET DE MANIPULATION

N'essayez pas de démonter et de nettoyer l'intérieur de la lunette car cela annulerait la garantie. Si la lunette doit être réparée, veuillez vous reporter à la section de garantie pour obtenir les consignes complètes.

Les surfaces optiques externes doivent parfois être nettoyées. Utilisez le chiffon pour lentille fourni ou un papier pour objectifs de qualité optique pour essuyer la poussière ou la saleté sur la surface externe de la lentille.

Pour retirer les gros grains de sable ou la saleté importante, utilisez une brosse à poil doux ou soufflez. Appliquez du liquide de nettoyage pour lentilles avant d'essuyer.

Remplacez toujours les couvercles de protection des lentilles lorsque la lunette n'est pas utilisée afin d'éviter que la poussière ne s'accumule à la surface des lentilles. Conservez l'unité dans un environnement à faible humidité.

Remarque: **N'utilisez jamais de mouchoir en papier, de tissu en coton épais ni en flanelle - ces matières peuvent rayer la surface de la lentille. Utilisez un liquide de nettoyage pour lentille et un tissu d'opticien pour nettoyer les lentilles.*

NE REGARDEZ JAMAIS DIRECTEMENT LE SOLEIL AVEC VOTRE LUNETTE D'OBSERVATION. CELA PEUT CAUSER DE GRAVES LÉSIONS OCULAIRES

2. UTILISER LE RÉTICULE

Les images de réticule avec leurs surtensions peuvent être vues sur les pages 6-15. Vous pouvez

télécharger le manuel d'instruction de réticule à partir du tag de spécifications du produit de la page du produit disponible au **www.athlonoptics.com**

GARANTIE À VIE MÉDAILLE D'OR ATHLON*

Exigez le maximum de votre équipement. Lorsque les choses tournent inopinément ou que des accidents surviennent, soyez assurés, Athlon Optics bénéficie d'une garantie transférable à vie. Athlon garantit la réparation ou le remplacement de votre produit s'il est endommagé par une utilisation normale. Gratuit; Pas de facture; Aucune inscription requise.

****Cette garantie ne couvre pas les dommages causés par des dommages délibérés, une mauvaise utilisation, un vol ou une maintenance effectuée par une personne autre que le service après-vente agréé Athlon.***



**SHARP, TIGHT
AND PRICED
JUST RIGHT!**

Toll free: 1-855-913-5678

contact@athlonoptics.com

801 N MEADOWBROOK DR,
OLATHE, KS 66062

athlonoptics.com