

感谢您购买本产品！无刷动力系统功率强大，错误的使用可能导致人身伤害和设备损坏，为此的我们强烈建议您在设备前仔细阅读本说明书，并严格遵守规定的操作程序。我们不承担因使用本产品或擅自对产品进行改造所引起的任何责任，包括但不限于对附带损失或间接损失的赔偿责任。

01 注意事项

- ★ 电调与相关连接部件连接前，请确保所有电线和连接部件绝缘良好，短路会毁坏电调。
- ★ 请务必仔细连接好各部件，若连接不良，您可能不能正常控制飞行器，或出现设备损坏等其他不可预知的情况。
- ★ 使用此电调前，请认真查看电调以及电机说明书，确保动力系统搭配合理，避免错误的搭配导致损害电调。
- ★ 若需对电调的输入输出线，插头做相关焊接时，为保证焊接牢靠，请使用至少 60W 功率的焊接设备进行焊接，并保证焊接设备可靠接地。
- ★ 勿使电调外部温度超过 100℃，高温将会毁坏电调并且可能导致电机损害造成炸机。
- ★ 工作时若要改变驱动电机转向则随意更改两根电调与电机的连接线次序即可。

02 产品特点

- ★ 多旋翼专用核心程序，油门响应速度大幅提升。
- ★ 专门针对盘式电机优化的固件，兼容性非常出色。
- ★ 微处理器采用独立的稳压 IC 供电，具有更好的抗干扰能力，大大降低失控的可能性。
- ★ 具有 RPM 信号、错误状态提示信号输出接口。
- ★ 实时输出油门、转速、电流、电容温度、MOS 管温度等数据。
- ★ 自动调节进角，高度智能化，出厂默认设置即可满足绝大多数应用。
- ★ 最高可支持刷新频率为 621Hz 的油门信号，兼容各种飞控。
- ★ 使用 DEO (Driving Efficiency Optimization) 驱动技术，具备更好的油门线性及更高的驱动效率。
- ★ PWM 驱动频率为 18KHz。
- ★ 支持在线升级电调固件 (需要 LCD 参数设定盒或 WIFI 模块)。

03 产品规格

型号	持续电流	瞬时电流 (10 秒)	BEC	锂电节数	参数选项	重量	体积
XRotor Pro-80A-HV-V3-RTF	80A	100A	无	6-14S	DEO (开/关)	118g	86.1*42.0*20.5mm (不含耳朵长度)
XRotor Pro-100A-HV-V3-RTF	100A	120A	无	6-14S	DEO (开/关)	134g	86.1*42.0*22.6mm (不含耳朵长度)

04 使用向导

油门行程校准:

警告！首次使用无刷电调或更换遥控设备后需要进行油门行程校准

第一步：油门行程校准接线方法

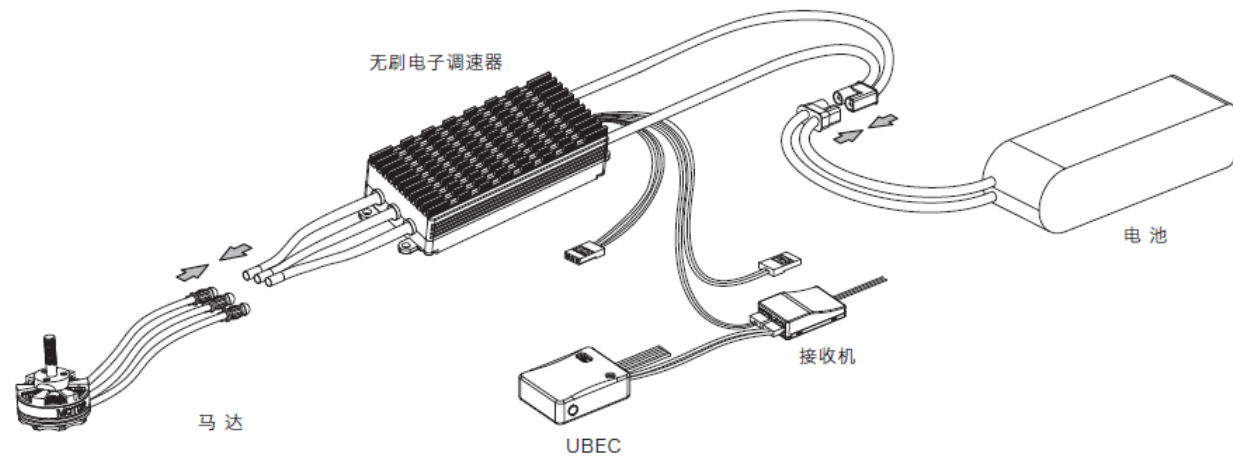

注:

- 1) 黑红白三色排线为参数设定和升级信号线
- 2) 黑线为地线

- 3) 白黑线为油门信号线
- 4) 细黄线为电机转速 (RPM) 信号输出线
- 5) 白线为错误状态提示信号线

第二步：参数设定操作方法

警告！进行油门行程校准时请将螺旋桨卸下以免发生意外！

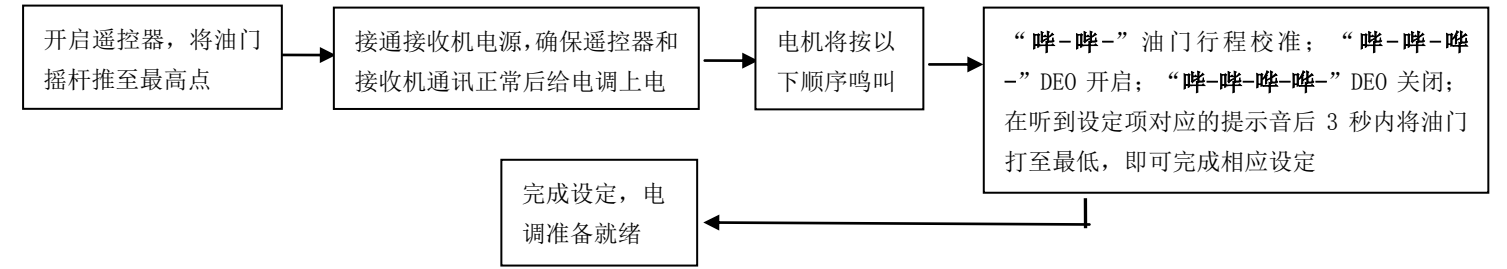

05 正常开机过程

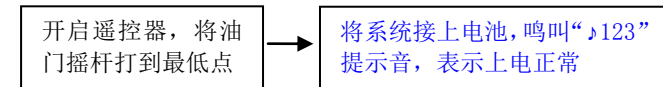

06 保护功能说明

本电调专为多旋翼飞行器设计，无低压保护。

- 1) **启动保护:** 当加大油门后两秒内未能正常启动马达，电调将关闭动力输出，油门摇杆需再次置于最低点后才可以重新启动。(出现这种情况的原因可能有：电调和马达连线接触不良或有个别输出线断开、螺旋桨被其他物体阻挡等)。
- 2) **堵转保护:** 当电调检测到电机发生堵转时，电调会彻底关闭输出并不再尝试重启电机，此时需将油门摇杆置于最低后重新推动油门摇杆，方可清除错误并重启电调恢复动力输出。
- 3) **电流保护:** 当瞬间电流异常达到接近 350A 时，电调立即关断输出，重新上电后可恢复正常。
- 4) **油门信号丢失保护:** 当电调检测到油门遥控信号丢失 0.25 秒以上立即关闭输出，以免因螺旋桨继续高速转动而造成更大的损失。信号恢复后，电调也随即恢复相应的功率输出。

07 常见故障及提示音说明

警示音说明

故障现象	警报音	可能原因	解决办法
上电后电机无法启动	“哔哔、哔哔哔、哔哔哔哔”	油门接反	设置遥控器反向油门
上电后电机无法启动	“哔哔哔...”的急促单音	油门未归零或行程设置过小	将油门打至最低点或重新校准油门行程
上电后电机无法启动	“哔、哔、哔、.....” (每个间隔 1 秒)	接收机油门通道无油门信号输出	检查发射机与接收机配合是否正常 检查油门控制通道接线是否正常
上电电压低于 18V	“哔哔、哔哔” (间隔 1 秒)	电池电压过低	更换合适的满电电池
上电电压高于 65V	“哔哔、哔哔” (间隔 1 秒)	电池电压过高	更换合适的满电电池

故障报错信号反馈说明

故障信号反馈	可能原因	解决办法
	电调过热达到 100℃	安全降落飞机并停止工作进行冷却
	电调过流达到 350A 左右	飞行器停止工作检查设备
	上电电压低于 18V	更换合适满电电池
	上电电压高于 65V	更换合适满电电池

Thank you for purchasing this HOBBYWING product! Brushless power systems can be very dangerous. Any improper use may cause personal injury and damage to the product and related devices. We strongly recommend reading through this user manual before use. Because we have no control over the use, installation, or maintenance of this product, no liability may be assumed for any damages or losses resulting from the use of the product. We do not assume responsibility for any losses caused by unauthorized modifications to our product.

**01 Warnings**

- ★ Ensure all wires and connections are well insulated before connecting the ESC to related devices, as short circuit will damage your ESC.
- ★ Ensure all devices are well connected to prevent poor connection that may cause your multi-rotor to lose control or other unpredictable issues such as damage to the device.
- ★ Read through the manuals of all power devices and ensure the power configuration is rational before using this unit.
- ★ Please use a soldering iron (ensuring it's connected to a GND wire) with the power of at least 60W to solder all input/output wires and connectors.
- ★ Stop using the ESC when its casing temperature exceeds 100°C, otherwise your ESC will get destroyed and may also get your motor damaged.
- ★ Please swap any two ESC-to-motor wires if the motor runs in reverse.

**02 Features**

- ★ Special core program for multi-rotor controllers greatly improves throttle response.
- ★ Specially optimized software for excellent compatibility with multi-rotor motors.
- ★ Microprocessor powered by independent DC regulator has better anti-interference performance greatly reduces the risk of losing control.
- ★ Separate signal wires for reminding user of RPM output & error states.
- ★ All settings except the timing are preset, making usage simple, high intelligent and adaptive.
- ★ Compatible with various flight-controller and supports a signal frequency of up to 621Hz.
- ★ DEO (Driving Efficiency Optimization) technology for better throttle linearity and higher driving efficiency.
- ★ PWM frequency of 18KHz.
- ★ Firmware upgrade via HOBBYWING multifunction LCD program box or WIFI module (item sold separately).

**03 Specifications**

Model	Con. C	Peak C (10s)	BEC	LiPo	Programmable Item	Weight	Size (L*W*H)
XRotor Pro-80A-HV-V3-RTF	80A	100A	No	6-14S	DEO (ON/OFF)	118g	86.1*42.0*20.5mm (Length w/o ears)
XRotor Pro-100A-HV-V3-RTF	100A	120A	No	6-14S	DEO (ON/OFF)	134g	86.1*42.0*22.6mm (Length w/o ears)

**04 User Guide**

**Throttle Calibration**

**Attention!** Users need to calibrate the throttle range when they start to use a new XRotor brushless ESC or another transmitter.

**Step 1: Wiring**

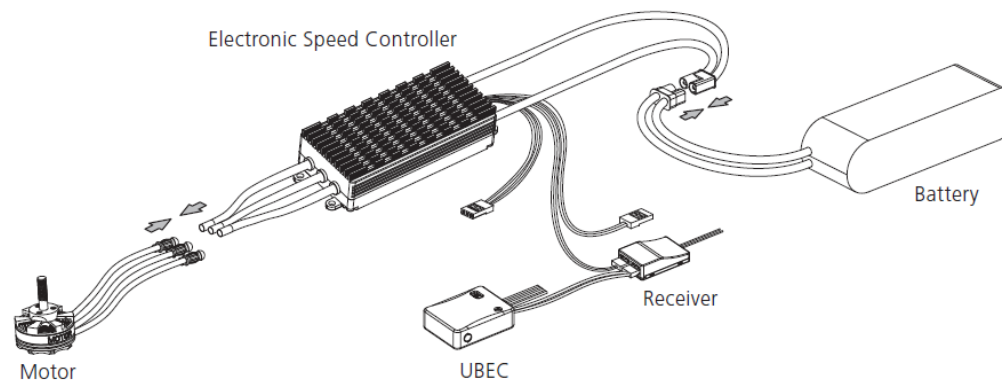

**Notes:**

- 6) The tri-color (Black/Red/White) cable is the programming cable.
- 7) The Black wire is the GND wire.
- 8) The bi-color (White/Black) cable is the throttle control cable
- 9) The Yellow wire is the RPM signal output wire.
- 10) The White wire is the signal wire for warning user of error states.

**Step 2: ESC Programming**

**Warning!** This is an extremely powerful brushless motor system. We strongly recommend removing your propellers for your own safety and the safety of others around you before performing calibration with this system.

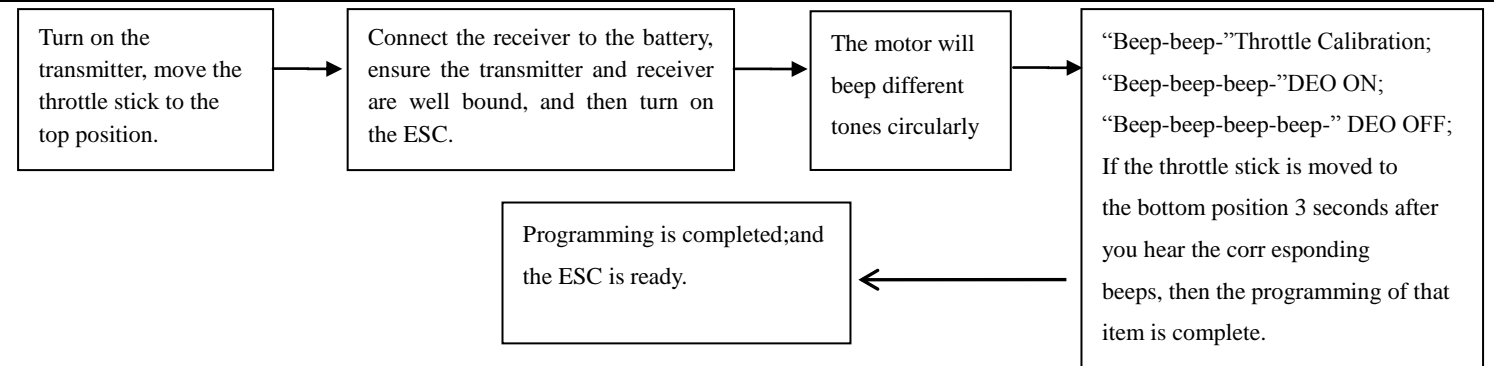

**05 Normal Start-up Process**

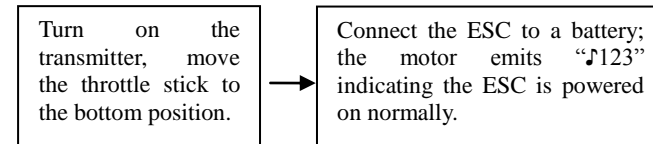

**06 Protections**

This ESC is specially designed for multi-rotors/drones; it has no low-voltage cutoff protection function.

**Start-up Protection:** The ESC will shut down the motor if it fails to start the motor normally within 2 seconds by increasing the throttle value. In this case, you need to move the transmitter throttle stick back to the bottom position and restart the motor. (Possible causes of this problem: poor connection/disconnection between the ESC and motor wires, propellers are blocked, etc.)

**Motor Lock-up Protection:** The ESC will cut off its output and stop trying to restart the motor when it detects the motor is locked up. It won't resume the output until you move the throttle stick to the bottom position first and then push the stick upward.

**Over-current Protection:** The ESC will cut off its output immediately when the peak current gets close to 350A (the short-circuit current). It only restarts after you power it off and then back on.

**Throttle Signal Loss Protection:** When the ESC detects loss of signal for over 0.25 second, it will cut off the output immediately to avoid an even greater loss which may be caused by the continuous high-speed rotation of propellers or rotor blades. The ESC will resume the corresponding output after normal signals are received.

**07 Trouble shooting**

Trouble	Warning Tone	Possible Cause	Solution
The ESC was unable to start the motor.	“BB, BBB, BBBB ...”	Reverse throttle	Please set the throttle direction to “REV” on the transmitter.
The ESC was unable to start the motor.	“B, B, B ...” (The motor beeped rapidly.)	The throttle stick is not moved to the bottom position or the throttle range is too narrow.	Move the throttle stick to the bottom position or recalibrate the throttle range.
The ESC was unable to start the motor.	“B-, B-, B-...” (The interval is 1 second.)	No output signal from the throttle channel on the receiver.	Check if the transmitter and receiver are well bound, if the throttle control cable has been properly plugged into the TH channel on the receiver.
The power-on voltage is below 18V.	“BB-, BB-...” (The interval is 1 second.)	The battery voltage is too low.	Change another suitable battery that is fully charged.
The power-on voltage is above 65V.	“BB-, BB-...” (The interval is 1 second.)	The battery voltage is too high.	Change another suitable battery that is fully charged.

**Explanations for errors/warnings**

Errors/Warnings	Possible Cause	Solution
	Overheat issue happened to the ESC.	Land the multi-rotor immediately and stop using it until the ESC cools down.
	Over-current issue happened to the ESC.	Stop using the multi-rotor, check if the ESC has the over-current issue.
	The power-on voltage is below 18V.	Change another suitable battery that is fully charged.
	The power-on voltage is above 65V.	Change another suitable battery that is fully charged.