

EZRUN
USER MANUAL
Sensored Brushless Motor
EZRUN 56118SD G2

20230420



Thank you for purchasing this HOBBYWING product! The power of brushless power system is powerful. Any improper use may cause personal injury and damage to the product and related devices. We strongly recommend reading through this user manual before use and strictly abide by the specified operating procedures. We shall not be liable for any liability arising from the use of this product, including but not limited to reimbursement for incidental or indirect losses. Meanwhile, we do not assume any responsibility caused by unauthorized modification of the product. We have the right to change the product design, appearance, performance and use requirements without notice.

01 Warnings

- Please carefully check power devices and manual of car frame to ensure the power pairing is reasonable. Avoid wrong pairing to overload and damage the motor.
- Always wire up all the parts of the equipment carefully. If any of the connections come loose as a result of vibration, your model RC may lose control.
- Never apply full throttle if the pinion is not installed. Due to the extremely high RPMs without load, the motor may get damaged.
- Never allow the motor case to get 100 degrees Celsius (212 degrees Fahrenheit) because the magnets maybe demagnetized by high temperature.

02 Features

- Compared with the previous generation, it has added a new waterproof sensor cable, upgraded to a sensed system, with better accelerate linearity and stronger explosive force.
- It has perfect compatibility when it is matched with Hobbywing EZRUN MAX5 HV G2 esc, the esc can automatically recognize this motor, and build a power system with full sensor mode, providing better control performance and more delicate control feel, and also realizing the motor overheat protection function.
- The independent high-precision encoder always outputs pure rotor position signal, which effectively avoids the interference of sensor signal and makes the motor work stably in sensor state.
- CNC machined aluminum housing, high purity copper windings, high strength explosion-proof rotor, ultrathin silicon steel laminations, high-quality stainless steel output shaft, high-precision bearing for high durability and smoothness.
- The innovative new sensor interface and rubber cover bearing have better waterproof and dustproof effect than the traditional sensor motor.

03 Specifications

Model	KV	LiPos	No-load Current	Diameter/Length	Shaft Diameter/Length	Bearing size (mm)	Poles	Weight	Applications
EZRUN 56118SD G2-650KV	650KV	8-12S	5.5A	φ=56mm(2.20") L=119.2mm(4.69")	φ=8mm(0.31") L=30mm(1.18")	Front: D22"D8*T7 Rear: D19"D8*T6	4	1272g	1/5th Buggy, Truck
EZRUN 56118SD G2-800KV	800KV	8-12S	6.9A					1277g	
EZRUN 56118SD G2-1100KV	1100KV	6-8S	8.0A					1287g	

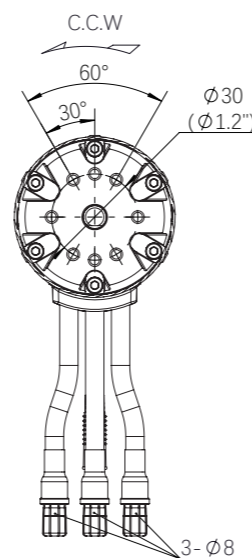
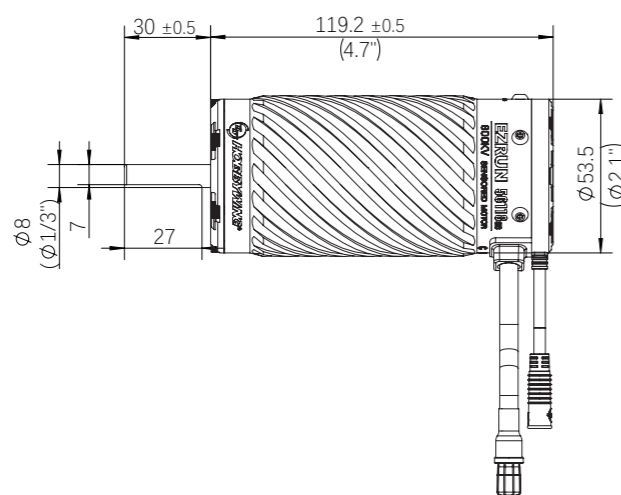
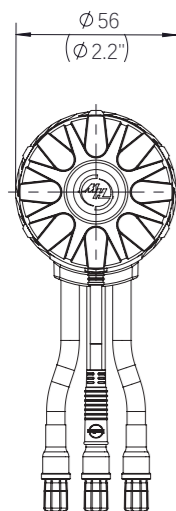

04 Installation & Connection

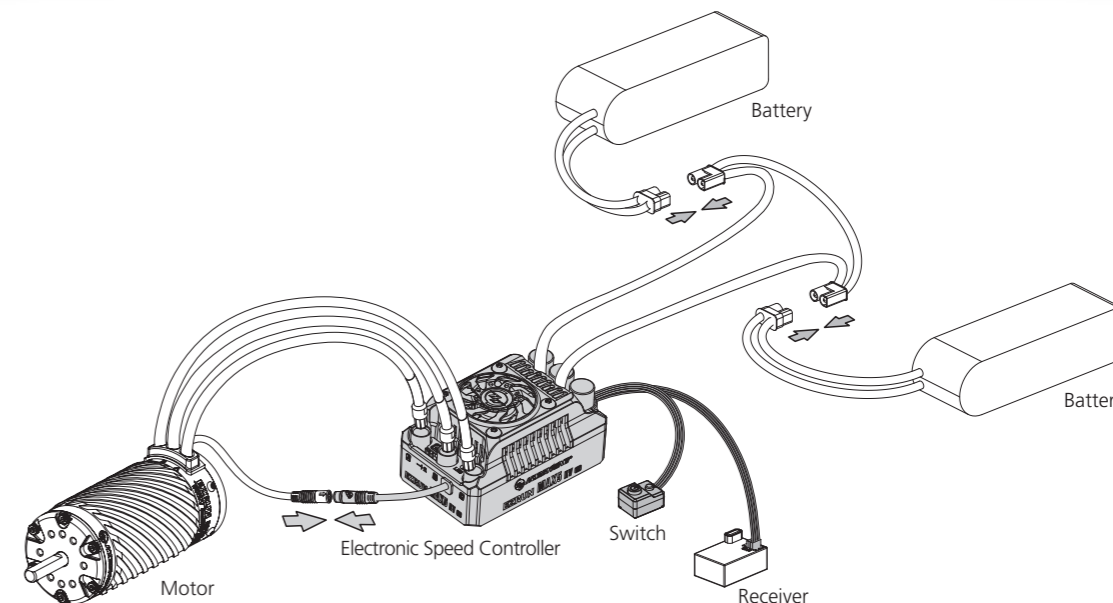

1. Install the motor

There are 8 motor mounting holes in M4 specification, and the mounting holes are 7mm in depth, before installing the motor on the vehicle, please carefully confirm whether the specification of the screws is appropriate, so as not to damage the motor due to excessive length.

2. How to Connect the Motor to an ESC

- When connecting the motor and esc, please pay attention to the marked three-phase position of A, B and C to ensure that the three wires of the motor and esc are connected correspondingly. Otherwise, it cannot run normally and even damage the esc and motor.
That is: Wire A of the esc matches wire A of the motor, wire B of the esc matches wire B of the motor, wire C of the esc matches wire C of the motor.
- When the sensor wire of the motor is connected with the sensor wire of the esc, it shall be connected correspondingly according to the arrow mark on the sensor interface.

3. Inspection

Before power on the esc, please check the reliability of the motor installation and the correctness of all connections.

05 Gearing

Reasonable selection of gear ratio is very important. Improper gear ratio may bring you great loss. You can select the gear ratio according to the following points!

1. The running temperature of the motor

The motor temperature should be lower than 100 degrees Celsius (212 degrees Fahrenheit) in operation. Because high temperature may cause the magnets to get demagnetized, the coil to get melt and short circuited, and the ESC to get damaged. A suitable gearing ratio can effectively prevent the motor from overheating.

2. The principle of selecting gear ratio

To avoid the possible damage to ESC and motor caused by the overheat, please start with a small pinion/a big FDR and check the motor temperature regularly. If the motor and ESC temperature always stay at a low level during the running, you can change a big pinion/a low FDR and also check the motor temperature regularly to ensure that the new FDR is suitable for your vehicle, local weather and track condition. (Note: For the safety of electric devices, please check the ESC and motor temperature regularly.)

06 Assembly and Disassembly

In order to make the motor have longer service life and higher efficiency, we suggest to regularly check the bearing and clean the dirt in the motor. The specific time depends on the frequency of using the motor and the site conditions. When installing, please follow the steps in the following assembly drawing; when disassembling, follow the reverse steps.

