



Treadmill

01-24

6830TA	6030EA
6830EA	
	6310CB
6840EA	
6841TA	6320CB
6841EA	
	6371CB
6750EA	
	6362TA
	6361TA
5556TA	
5552EA	6360EA



ELLIPTICAL & BIKE

25-54

E17	E12-V5
E17-V2	E12-V6
E17-V3	
E17-V4	
E17-V5	E12
	E12-V2
E29	
E29-V1	B11
	B11-V1
E29-V2	B11-V3
E29-V3	R11-V4
E29-V4	
	R11-V1
E20	R11-V2
E10-V1	
	R11-V4
	R11-V5
E31	
E33	S12
	LT01
J22	
E15	



STRENGTH

55-74

L818-V1	L305
	L306
L819	L308
	L311
L838	
	L105
L101	L106
	L119
L131	L110
	L107
L131+132	L111
	L115
L301	L115B
L302	L177
L303	
L304	



CONTENTS



TREADMILL



6830EA

	6830TA	6830EA
Motor	DC Brushless motor 4.0HP	DC Brushless motor 4.0HP
Speed range	1-22km/h	1-22km/h
Motor incline	0-15 levels	0-15 levels
Running Surface(mm)	1470x550mm	1470x550mm
N.W./G.W.(kg)	130/145kg	130/145kg
loading quality 20FT/40FT/40HQ	35/72/84pcs	35/72/84pcs



Display function

- 23.8" TFT touch screen provide 36 pre-set programs +1 manual+ 3 user' manual
- Handle pulse
- Body fat function
- Option:MP3 socket and built-in speaker , HRC + built-in receiver









Display function

- 7 windows white LED dot-matrix display provide 36 pre-set programs +1 manual+ 3 user's manual
- Handle pulse
- Body fat function
- Option:MP3 socket and built-in speaker , Bluetooth music, Bluetooth to connect APP and Heartrate wireless receiver, HRC + built-in receiver

TREADMILL



6840EA

	6840EA
 Motor	AC, 4.0HP
 Speed range	1-22km/h
 Motor incline	0-15 levels
 Running Surface(mm)	1550x560mm
 N.W./G.W.(kg)	167/187kg
 loading quality 20FT/40FT/40HQ	27/54/65pcs



Display function

- White LED screen provide 36 pre-set programmes and 1 manual +3 user's manual
- Handle pulse
- Body fat function
- Option:MP3 socket and 2 built-in speaker, Built-in wireless reciever

TREADMILL



6841EA

	6841TA	6841EA
Motor	AC, 4.0HP	AC, 4.0HP
Speed range	1-22km/h	1-22km/h
Motor incline	0-15 levels	0-15 levels
Running Surface(mm)	1550x560mm	1550x560mm
N.W./G.W.(kg)	143.5+21/162+28kg	143.5+21/162+28kg
loading quality 20FT/40FT/40HQ	24/50/59pcs	24/50/59pcs



Display function

- 15.6" TFT touch screen provide 36 pre-set programs +1 manual+ 3 user's manual
- Handle pulse
- Body fat function
- Option: HRC + built-in receiver









Display function

- White LED screen provide 36 pre-set programmes and 1 manual +3 user's manual
- Handle pulse
- Body fat function
- Option:MP3 socket and built-in speaker, Bluetooth music, Bluetooth to connect APP and Heartrate wireless receiver, HRC + built-in receiver

TREADMILL



6750EA

		6750EA
	Motor	AC, 5.0HP
	Speed range	1-22km/h
	Motor incline	0-15 levels
	Running Surface(mm)	1560x580mm
	N.W./G.W.(kg)	205/225kg
	loading quality 20FT/40FT/40HQ	20/40/50pcs



Display function

- White 7 LED windows, dot matrix screen provide 36 pre-set programs + 3 user's programs + 1 manual
- Handle pulse
- Body fat function
- Option:HRC + built-in Polar receiver, MP3 input and built-in speakers, USB charger

TREADMILL



5556TA

	5556TA	5556EA
Motor	AC.6.0HP	AC.6.0HP
Speed range	1-25km/h	1-25km/h
Motor incline	0-15 levels	0-15 levels
Running Surface(mm)	1620x600mm	1620x600mm
N.W./G.W.(kg)	47+151/55+171kg	47+151/55+171kg
loading quality 20FT/40FT/40HQ	22/44/48pcs	22/44/48pcs



Display function

- 21.5" TFT touch screen provide 36 pre-set programs +3 user's manual, Media
- Handle pulse
- Two built-in speakers
- USB charger and input
- Headphone output
- Quick speed and incline button on console
- Option: Cooling fan, HRC + Polar built-in receiver









Display function

- LED dot matrix screen provide 36 pre-set programs + 3 user's programs + 1 manual
- Handle pulse
- Body fat function
- MP3 socket and built-in speaker
- Option: USB charger and input, Headphone output, cooling fan, HRC + Polar built-in receiver

TREADMILL



6030EA

		6030EA
	Motor	DC 3.0HP
	Speed range	1-16km/h
	Motor incline	-6-36 levels
	Running Surface(mm)	1400x500mm
	N.W./G.W.(kg)	N.W.110KG/G.W.120KG
	loading quality 20FT/40FT/40HQ	38/83/83pcs



Display function

- white LED windows, showing speed, time, calories, distance, incline
- Handle pulse
- **Option:** Bluetooth music and 2 built-in speakers , HRC + built-in receiver , Bluetooth to connect APP and Heart rate wireless receiver

TREADMILL



6310CB

	6310CB
Motor	/
Speed range	unlimited
Resistance	1-4 levels
Running Surface(mm)	1600x440mm
N.W./G.W.(kg)	128/149kg
loading quality 20FT/40FT/40HQ	30/65/65pcs



Display function

- Large LCD screen displays 7 workout modes including 20/10, 20/10 custom intervals, 4 target settings.

TREADMILL



6320CB

	6320CB
Motor	/
Speed range	unlimited
Resistance	1-4 levels
Running Surface(mm)	1600x480mm
N.W./G.W.(kg)	133/153kg
loading quality 20FT/40FT/40HQ	30/60/60pcs



Display function

- Large LCD screen displays 7 workout modes including 20/10, 20/10 custom intervals, 4 target settings.

TREADMILL



6371CB

	6371CB
Motor	/
Speed range	unlimited
Resistance	1-4 levels
Running Surface(mm)	1600x480mm
N.W./G.W.(kg)	161/187kg
loading quality 20FT/40FT/40HQ	24/48/60pcs



Display function

- Large LCD screen displays 7 workout modes including 20/10, 20/10 custom intervals, 4 target settings.

TREADMILL



6362TA

	6362TA	6361TA
Motor	Serve motor, 2.5HP	Serve motor, 2.5HP
Speed range	1-22km/h	1-22km/h
Motor incline	0-15 levels	0-15 levels
Running Surface(mm)	1600x550mm	1600x550mm
N.W./G.W.(kg)	216/248kg	210/240kg
loading quality 20FT/40FT/40HQ	25/60/60pcs	25/60/60pcs



Display function

- 32" TFT touch screen (1920 x 1080) , Wifi, Media
- Bluetooth heart rate
- With MP3 socket
- With USB port
- With headphone socket
- With 3 pre-set programs: Sled, running, manual running
- Sled resistance training with 36 sections control
- Under manual running mode, slope angle can be adjusted by power elevation
- For exerciser, you can use from warm-up, running, cool down, relax different function with one machine



Display function

- 21.5" TFT touch screen (1920 x 1080) , Wifi, Media
- Easily operation with speed knob and incline knob
- on handle bar
- Bluetooth heart rate
- With MP3 socket
- With USB port
- With headphone socket
- With 3 pre-set programs: Sled, running, manual running
- Sled resistance training with 36 sections control
- Under manual running mode, slope angle can be adjusted by power elevation
- For exerciser, you can use from warm-up, running, cool down, relax different function with one machine

TREADMILL



	6360EA
Motor	Serve motor, 2.5HP
Speed range	1-22km/h
Motor incline	0-15 levels
Running Surface(mm)	1600x550mm
N.W./G.W.(kg)	191/221kg
loading quality 20FT/40FT/40HQ	25/60/60pcs



Display function

- LED display
- Bluetooth heart rate
- With 3 pre-set programs: Sled, running, manual running
- Sled resistance training with 36 sections control
- Under manual running mode, slope angle can be adjusted by power elevation
- For exerciser, you can use from warm-up, running, cool down, relax different function with one machine



ELLIPTICAL & BIKE



E17

	E17	E17-V2	E17-V3	E17-V4	E17-V5
System	EMS	EMS	EMS	GMS(self-generator)	EMS
User Weight	170kg	170kg	170kg	170kg	170kg
Pulse	Hand pulse	Hand pulse	Hand pulse	Hand pulse	Hand pulse
Power Supply	AC plug	AC plug	AC plug	/	AC plug
Certificate	EN957, RoHS	EN957, RoHS	EN957, RoHS	EN957, RoHS	EN957, RoHS
Stride length	22"	22"	22"	22"	22"
Flywheel	10kg, two-way flywheel	10kg, two-way flywheel	10kg, two-way flywheel	14.2kgs, two-way flywheel	10kg, two-way flywheel
Crank Arm	273 mm	273 mm	273 mm	273 mm	273 mm
Resistance	40 Levels	40 Levels	40 Levels	40 Levels	40 Levels
Motor incline	20 Levels	/	20 Levels	/	/
N.W./G.W.(kg)	126.5/139kg	122.5/135kg	128.5/141kg	142/157kg	128.5/141kg
Assembly Size (mm)	2000×865×1835mm	2000×865×1835mm	2000×865×1835mm	2000×865×1835mm	2000×865×1835mm
loading quality 20FT/40FT/40HQ	36/72/72pcs	36/72/72pcs	36/72/72pcs	36/72/72pcs	36/72/72pcs

E17
E17-V2
E17-V4



Display function

- LED five windows with dot matrix, Size: 440×340×95mm
- Function: Time, Speed, Distance, Calories, Pulse, RPM, Watt, Cardio, Watt program,
- User-defined mode, 12 pre-programs
Preset program: manual, interval, weight loss, target heart rate, fit test, random, warm up and warm down, etc total 12 programs
- Hand pulse
- **Option:** Bluetooth, Earphone port + speakers

E17-V3
E17-V5



Display function

- 15.6" TFT touch screen
- Function: Time, Speed, Distance, Calories, Pulse, RPM, Watt, Cardio, Watt program, User-defined mode, 12 pre-programs
Preset program: manual, interval, weight loss, target heart rate, fit test, random, warm up and warm down, etc total 12 programs
- Hand pulse
- Earphone port + speakers
- **Option:** Bluetooth

ELLIPTICAL & BIKE



E29

	E29	E29-V1
System	PMS	PMS
User Weight	150kg	150kg
Pulse	Hand pulse	Hand pulse
Resistance	32 Levels	32 Levels
Power Supply	AC plug	AC plug
Certificate	EN957, RoHS	EN957, RoHS
Stride length	19"	19"
Flywheel	9kgs, two-way flywheel	9kgs, two-way flywheel
Crank Arm	3 pcs	3 pcs
Resistance	32 Levels	32 Levels
Motor incline	/	20 Levels
N.W./G.W.(kg)	94/105kg	99.5/111kg
Assembly Size (mm)	1580x630x1700mm	1580x630x1700mm
loading quality 20FT/40FT/40HQ	48/105/105pcs	48/105/105pcs



Display function

- LED five windows with dot matrix, Size: 440x340x95mm
- Function: Time, Speed, Distance, Calories, Pulse, RPM, Watt,
- Cardio, Watt program, Users manual mode, 12 pre-programs
Preset program: manual, interval, weight loss, target heart rate, fit test, random, warm up and warm down, etc total 12 programs
- Hand pulse
- Option: MP3 socket + speakers , Bluetooth , NFC charger

ELLIPTICAL & BIKE



E29-V2

	E29-V2	E29-V3	E29-V4
System	PMS	PMS	GMS(self-generator)
User Weight	150kg	150kg	150kg
Pulse	Hand pulse	Hand pulse	Hand pulse
Resistance	32 Levels	32 Levels	32 Levels
Power Supply	AC plug	AC plug	self-generator
Certificate	EN957, RoHS	EN957, RoHS	EN957, RoHS
Stride length	19"	19"	19"
Flywheel	9kgs, two-way flywheel	9kgs, two-way flywheel	14.2kgs, two-way flywheel
Crank Arm	3 pcs	3 pcs	3 pcs
Resistance	32 Levels	32 Levels	32 Levels
Motor incline	/	20 Levels	/
N.W./G.W.(kg)	94/105kg	99.5/111kg	99/110kg
Assembly Size (mm)	1580x630x1700mm	1580x630x1700mm	1580x630x1700mm
loading quality 20FT/40FT/40HQ	48/105/105pcs	48/105/105pcs	48/105/105pcs

E29-V2
E29-V3



Display function

- 10.1" TFT touch screen
- Function: Time, Speed, Distance, Calories, Pulse, RPM, Watt, Cardio, Watt program, Users manual mode, 12 pre-programs
Preset program: manual, interval, weight loss, target heart rate, fit test, random, warm up and warm down, etc total 12 programs
- Hand pulse
- Option: MP3 socket + speakers, Bluetooth, NFC charger

E29-V4



Display function

- LED five windows with dot matrix, Size: 440x340x95mm
- Function: Time, Speed, Distance, Calories, Pulse, RPM, Watt, Cardio, Watt program, Users manual mode, 12 pre-programs
Preset program: manual, interval, weight loss, target heart rate, fit test, random, warm up and warm down, etc total 12 programs
- Hand pulse
- Option: MP3 socket + speakers, Bluetooth, NFC charger

ELLIPTICAL & BIKE



E31

E33

	E31	E33
System	PMS	GMS (self-generator)
User Weight	150kg	170kgs
Pulse	Hand pulse	Hand pulse
Resistance	32 Levels	32 Levels
Power Supply	AC plug	/
Certificate	En957, RoHS	EN957, RoHS
Stride length	19"	19"
Flywheel	9kgs,two-way flywheel	14.2kgs,two-way flywheel
Crank Arm	3pcs	3pcs
Water Bottle Cage	Yes	Yes
N.W./G.W.(kg)	81/93kg	86/98kg
Assembly Size (mm)	2005 x 635 x 1762mm	2005 x 635 x 1762mm
loading quality 20FT/40FT/40HQ	41/89/90pcs	41/89/90pcs



Display function

- **Function:**Time, Speed, Distance, Calories, Pulse, RPM, Watt, Cardio (if W/BT) , Watt program, Recovery and Body Fat, User-defined mode, etc total 12 pre-programs
- **Preset program:**manual, interval, weight loss, target heart rate, fit test, random, warm up and warm down, etc total 12 programs
LED windows, with smart phone holder
- Hand pulse
- **Option :** I-pad holder, fan, bluetooth, MP3 input and built-in speaker



Display function

- **Function:**Time, Speed, Distance, Calories, Pulse, RPM, Watt, Cardio (if W/BT) , Watt program, Recovery and Body Fat, User-defined mode, etc total 12 pre-programs
- **Preset program:**manual, interval, weight loss, target heart rate, fit test, random, warm up and warm down, etc total 12 programs
LED windows, with smart phone holder
- Hand pulse
- **Option :** I-pad holder, fan, bluetooth, MP3 input and built-in speaker

ELLIPTICAL & BIKE



E20



E10-V1

	E20	E10-V1
System	PMS	GMS
User Weight	150kg	150kg
Pulse	Hand pulse	Hand pulse
Power Supply	adaptor	Self-Generator
Stride length	20"	20"
Flywheel	9kg	14.2kg
Crank Arm	257 mm	257mm
Resistance	32 Levels	20 Levels
Water Bottle Cage	Yes	Yes
N.W./G.W.(kg)	112/128kg	141/170.5kg
Assembly Size (mm)	2145x666x1740mm	2020x750x1740mm
loading quality 20FT/40FT/40HQ	36/75/75pcs	20/41/42pcs



Display function

- LED five windows with dot matrix, Size: 330*300mm
- Function: Scan, Time, Speed, Distance, Calories, Pulse, RPM, resistance level, Watt, Console
- program: Manual, Beginner, Advance, Sporty, Cardio(W/BT), Watt program, Recovery and
- Body Fat, etc total 12 programs
- Hand pulse
- Option: MP3 input and built-in speaker

ELLIPTICAL & BIKE



J22



E15

	J22	E15
System	Magnetic+air fan	Magnetic+air fan
User Weight	150kg	150kg
Pulse	Hand pulse	Hand pulse
Power Supply	AC plug	AC plug
Stride length	264mm	20"
Flywheel	8 kg	8 kg
Crank Arm	146mm	247mm
Resistance	24 Levels	24 Levels
Motor incline	0-15 levels	/
N.W./G.W.(kg)	107/126kg	97/114kg
Assembly Size (mm)	1660x880x1780mm	1620x650x1800mm
loading quality 20FT/40FT/40HQ	32/64/80pcs	39/87/87pcs



Display function

- LED with dot matrix, Size: 340*440mm
Function: Time, distance, calories, speed, incline level, resistance level, watts, pulse, profile
Preset program: manual, interval, weight loss, target heart rate, fit test, random, warm up and warm down, etc total 12 programs
- Hand pulse
- Option:USB charger , MP3 socket + speckers , Fan

ELLIPTICAL & BIKE



E12-V5

	E12-V5	E12-V6
System	EMS	EMS
User Weight	150kg	150kg
Pulse	Hand pulse	Hand pulse
Power Supply	AC plug	AC plug
Stride Length	21"	21"
Flywheel	12kg	12kg
Crank Arm	254mm	266.7mm
Resistance	20 Levels	20 Levels
Motor Incline	/	0-15 levels
N.W./G.W.(kg)	139.5/171.5kg	139.5/171.5kg
Assembly Size (mm)	2150×770×1940mm	2150×770×1940mm
loading quality 20FT/40FT/40HQ	14/28/41pcs	14/28/41pcs



Display function

- LED with dot matrix, Size: 370*460*80mm
- Function: Time, distance, calories, speed, incline level, resistance level, watts, pulse, profile
- Pre-set programs: manual, interval, weight loss, target heart rate, fit test, random, warm up and warm down, etc total 12 programs
- Hand pulse
- **Option** : I-pad holder, fan, bluetooth, MP3 input and built-in speaker



Display function

- 15.6" TFT touch screen Available language: English/German/French/Spanish/Japanese/Traditional Chinese Size: 370*460*80mm
- Function: Time, distance, calories, speed, incline level, resistance level, watts, pulse, profile
- Pre-set programs: manual, interval, weight loss, target heart rate, fit test, random, warm up and warm down, etc total 12 programs ,
- Wireless charger
- Build-in speakers
- Bluetooth heart rate

ELLIPTICAL & BIKE



B11-V3

	B11-V3	B11-V4
System	GMS (self-generator)	EMS
User Weight	150kg	150kg
Pulse	Hand pulse	Hand pulse
Power Supply	Self-Generator	AC plug
Flywheel	15 kg	8 kg
Crank Arm	175mm	175mm
Resistance	20 Levels	20 Levels
Water bottle Cage	yes	yes
N.W./G.W.(kg)	61.5/71.5kg	61.5/71.5kg
Assembly Size (mm)	1200x590x1510mm	1200x590x1510mm
loading quality 20FT/40FT/40HQ	80/166/186pcs	80/166/186pcs



Display function

- LED with dot matrix, Size: 417*310*45mm
- Function: Time, distance, calories, speed, resistance level, watts, pulse, profile
- Pre-set programs: manual, interval, weight loss, target heart rate, fit test, random, warm up and warm down, etc total 12 programs
- Hand pulse
- Wireless charger
- Bluetooth heart rate



Display function

- 15.6" TFT touch screen Available language: English/German/French/Spanish/Japanese/Traditional Chinese Size: 370*460*80mm
- Function: Time, distance, calories, speed, incline level, resistance level, watts, pulse, profile
- Pre-set programs: manual, interval, weight loss, target heart rate, fit test, random, warm up and warm down, etc total 12 programs ,
- Wireless charger
- Build-in speakers
- Bluetooth heart rate

ELLIPTICAL & BIKE



R11-V5

	R11-V4	R11-V5
System	GMS (self-generator)	EMS
User Weight	150kg	150kg
Pulse	Hand pulse	Hand pulse
Power Supply	Self-Generator	AC plug
Certificate	En957, RoHS	En957, RoHS
Flywheel	15 kgs	8 kgs
Crank Arm	175mm	175mm
Resistance	20 Levels	20 Levels
Water bottle Cage	yes	yes
N.W./G.W.(kg)	80/95kg	80/95kg
Assembly Size (mm)	1615x710x1390mm	1615x710x1390mm
loading quality 20FT/40FT/40HQ	44/93/120pcs	44/93/120pcs



Display function

- LED with dot matrix, Size: 417*310*45mm
- Function: Time, distance, calories, speed, resistance level, watts, pulse, profile
Pre-set programs: manual, interval, weight loss, target heart rate, fit test, random, warm up and warm down, etc total 12 programs
- Hand pulse
Wireless charger
Bluetooth heart rate



Display function

- 15.6" TFT touch screen Available language: English/German/French/Spanish/Japanese/Traditional Chinese Size: 370*460*80mm
- Function: Time, distance, calories, speed, incline level, resistance level, watts, pulse, profile
Pre-set programs: manual, interval, weight loss, target heart rate, fit test, random, warm up and warm down, etc total 12 programs ,
- Wireless charger
- Build-in speakers
- Bluetooth heart rate

ELLIPTICAL & BIKE



E12

	E12	E12-V2
System	EMS	EMS
User Weight	150kg	150kg
Pulse	Hand pulse	Hand pulse
Power Supply	AC plug	AC plug
Stride Length	21"	21"
Flywheel	10kg	10kg
Crank Arm	266.7mm	266.7mm
Resistance	20 Levels	32 Levels
Motor Incline	0-15 levels	0-15 levels
N.W./G.W.(kg)	139.5/171.5kg	139.5/171.5kg
Assembly Size (mm)	2436x660x1773mm	2436x660x1773mm
loading quality 20FT/40FT/40HQ	14/28/41pcs	14/28/41pcs



Display function

- LED with dot matrix, Size: 340x440mm
- Function: Time, distance, calories, speed, resistance level, watts, pulse, profile, fan, mp3Preset
- Program: manual, interval, weight loss, target heart rate, fit test, random, warm up and warm down, etc total 12 programs
- Hand pulse
- USB charger, MP3 socket + speakers, Fan



Display function

- 10.1" TFT touch screen, Size: 340*440mm
- Function: Time, distance, calories, speed, resistance level, watts, pulse, profile, fan, mp3Preset
- Program: manual, interval, weight loss, target heart rate, fit test, random, warm up and warm down, etc total 12 programs
- Hand pulse
- USB charger, MP3 socket + speakers, Fan

ELLIPTICAL & BIKE



B11

	B11	B11-V1
System	GMS(self-generator)	EMS
User Weight	150kg	150kg
Pulse	Hand pulse	Hand pulse
Power Supply	Self-Generator	Self-Generator
Flywheel	15 kg	8 kg
Crank Arm	170mm	170mm
Resistance	20 Levels	32 Levels
Water bottle Cage	yes	yes
N.W./G.W.(kg)	59/69kg	53/69kg
Assembly Size (mm)	2150x770x1940mm	2150x770x1940mm
loading quality 20FT/40FT/40HQ	80/166/186pcs	80/166/186pcs



Display function

- LED with dot matrix, Size: 340*440mm
- Function: Time, distance, calories, speed, incline level, resistance level, watts, pulse, profile
- Preset program: manual, interval, weight loss, target heart rate, fit test, random, warm up and warm down, etc total 12 programs
- Hand pulse
- USB charger, MP3 socket + speakers, Fan



Display function

- 10.1" TFT touch screen, Size: 340*440mm
- Function: Time, distance, calories, speed, resistance level, watts, pulse, profile, fan, mp3
- Preset program: manual, interval, weight loss, target heart rate, fit test, random, warm up and warm down, etc total 12 programs
- Hand pulse
- USB charger, MP3 socket + speakers, Fan

ELLIPTICAL & BIKE



	R11-V1	R11-V2
System	EMS	GMS(self-generator)
User Weight	150kg	150kg
Pulse	Hand pulse	Hand pulse
Power Supply	AC plug	Self-Generator
Certificate	En957, RoHS	En957, RoHS
Flywheel	8kg	8kg
Crank Arm	170mm	170mm
Resistance	32 Levels	20 Levels
Water bottle Cage	yes	yes
N.W./G.W.(kg)	73/86kg	80/92kg
Assembly Size (mm)	1615x710x1390mm	1615x710x1390mm
loading quality 20FT/40FT/40HQ	44/93/120pcs	44/93/120pcs



Display function

- 10.1" TFT touch screen, Size: 340*440mm
- Function: Time, distance, calories, speed, resistance level, watts, pulse, profile, fan, mp3
- Pre-set program: manual, interval, weight loss, target heart rate, fit test, random, warm up and warm down, etc total 12 programs Hand pulse
- USB charger, MP3 socket + speakers, Fan



Display function

- LED with dot matrix, Size: 340x440mm
- Function: Time, distance, calories, speed, resistance level, watts, pulse, profile, fan, mp3
- Pre-set program: manual, interval, weight loss, target heart rate, fit test, random, warm up and warm down, etc total 12 programs
- Hand pulse
- USB charger, MP3 socket + speakers, Fan

ELLIPTICAL & BIKE



S12

	S12
System	Magnetic
User Weight	150kg
Pulse	Yes
Resistance	Stepless
Power Supply	w/o
Flywheel	Aluminium ally,5.5kgs
Crank Arm	Aquare cone crank
Water Bottle Cage	w/o
Transpoetation	belt
N.W./G.W.(kg)	51.5/62.850kg
Assembly Size (mm)	1588x560x1310mm
loading quality 20FT/40FT/40HQ	92/192/221pcs



ELLIPTICAL & BIKE

LT01



	LT01
Motor	2.0HP
Speed Range	14-140steps/min
Power Supply	AC plug
Max	160kg
N.W./G.W.(kg)	175/205kg
Assembly Size (mm)	1465x810x2255mm
loading quality 20FT/40FT/40HQ	7/15/15pcs



Display function

- White light LED screen provide 36 pre-set program and 1 manual + 3 user's manual
- Pace counting
- Option:MP3 input and two built-in speakers, USB charger and input

3 **STRENGTH**



STRENGTH



	L818-V1
Resistance control	Maximum resistance is 50kg x 2
Pulling rope	2000mm and maximum weight 300kg
Pulley	POM
Console	1062x465mm mirror surface, 5 LED window display: time, calorie, resistance, count With MP3 and built-in speaker and speaker With bluetooth for music
Footplate	Included
Footprint unfolding size(mm)	1685x950x1785mm
Footprint folding size(mm)	580x950x1785mm
N.W/G.W(kg)	126/146kg
Loading QTY 20GP/40GP/40HQ	67/137/153pcs



STRENGTH



	L819
Resistance control	Maximum resistance is 50kg x 2
Pulling rope	2000mm and maximum weight 300kg
Pulley	POM
Console	618x955.8mm mirror surface, 5 LED window display: time, calorie, resistance, count, etc. With MP3 and built-in speaker
Pilates	Included
Assembly size	2718x820x1832mm
Loading QTY 20GP/40GP/40HQ	60/129/163pcs



STRENGTH



	L838
Resistance control	Maximum resistance is 60kg x 2
Input voltage	220V
Pulling rope	2000mm and maximum weight 300kg
Pulley	POM
Console	32.8" TFT
Footplate	Included
Assembly size	2000x730x1750mm
Loading QTY 20GP/40GP/40HQ	TBC

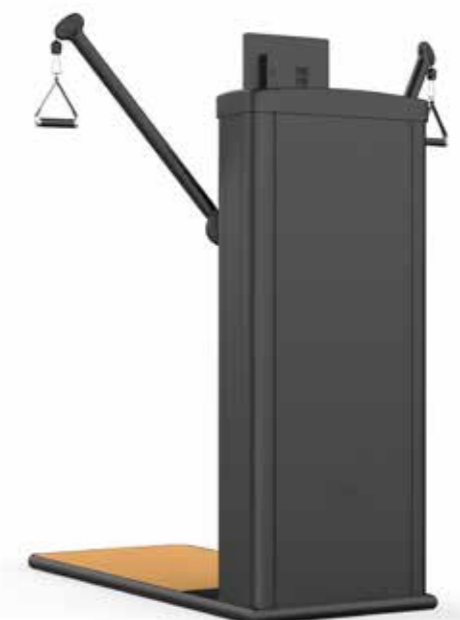

STRENGTH



	L101
Exercise area	300x250cm
Assemble size	219x139x225cm
Main frame tube size	PT50x100x2.0mm Dual handle bar can be adjusted with 16 levels in range of 160cm
Stack	A3 steel 60kgx2=120kg(standard) 90kgx2=180kg(optional)
Steel cable	Φ 4.8 pu coated
Max loading of cable	600kg
Pulley	Φ 90 POM pulley
N.W/G.W(kg)	360kg/382kg (excluding weight stack)
Loading QTY 20GP/40GP/40HQ	36/77/89pcs



STRENGTH



		L131
Exercise area	150x250cm	
Assemble size	190.8x85x210cm	
Main frame tube size	PT50x100x2.0mm D55x62x2.0mm	
Stack	A3 steel	60kg (standard) 90kg (optional)
Steel cable	Φ 4.8 pu coated	
Max loading of cable	600kg	
Pulley	Φ 90 POM pulley	
N.W/G.W(kg)	226kg/248kg (excluding weight stack)	
Loading QTY 20GP/40GP/40HQ	31/62/72pcs	



STRENGTH

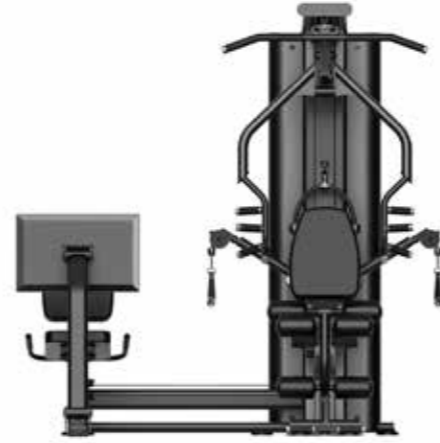

	L131	+	L132
Exercise area	300x300cm		
Assemble size	190.8x85x210cm		176x158x104cm
Main frame tube size	PT50x100x2.0mm D55x62x2.0mm PT40x80x2.0mm		PT50x100x2.0mm PT40x80x2.0mm
Stack	A3 steel 60kg (standard) 90kg (optional)		/
Steel cable	Φ 4.8 pu coated		Φ 4.8 pu coated
Max loading of cable	600kg		600kg
Pulley	Φ90 POM pulley		POM pulley With Kick function
N.W/G.W(kg)	226kg/248kg		80kg/85kg
Loading QTY 20GP/40GP/40HQ	31/62/72pcs		



STRENGTH



	L301
Assemble size	192x129x153cm
Main frame tube size	PT50x120x2.0mm PT50x100x2.0mm
Stack	60kg (standard) 90kg (optional)
Steel cable	Φ 4.8 pu coated
Pulley	Φ 115 POM pulley



	L303
Assemble size	121x130x153cm
Main frame tube size	PT50x120x2.0mm PT50x100x2.0mm
Stack	60kg (standard) 90kg (optional)
Steel cable	Φ 4.8 pu coated
Pulley	Φ 115 POM pulley

	L302
Assemble size	118x102x153cm
Main frame tube size	PT50x120x2.0mm PT50x100x2.0mm
Stack	60kg (standard) 90kg (optional)
Steel cable	Φ 4.8 pu coated
Pulley	Φ 115 POM pulley



	L304
Assemble size	158x73x153cm
Main frame tube size	PT50x120x2.0mm PT50x100x2.0mm
Stack	60kg (standard) 90kg (optional)
Steel cable	Φ 4.8 pu coated
Pulley	Φ 115 POM pulley



STRENGTH



	L305
Assemble size	175x74x222cm
Main frame tube size	PT50x120x2.0mm PT50x100x2.0mm
Stack	60kg (standard) 90kg (optional)
Steel cable	Φ 4.8 pu coated
Pulley	Φ 115 POM pulley



	L308
Assemble size	222x133x146.5cm
Main frame tube size	PT50x120x2.0mm PT50x100x2.0mm
Stack	60kg (standard) 90kg (optional)
Steel cable	Φ 4.8 pu coated
Pulley	Φ 115 POM pulley

	L306
Assemble size	107.4x100x103.3cm
Main frame tube size	PT50x120x2.0mm PT50x100x2.0mm
Stack	60kg (standard) 90kg (optional)
Steel cable	Φ 4.8 pu coated
Pulley	Φ 115 POM pulley



	L311
Assemble size	192x115x164cm
Main frame tube size	PT50x120x2.0mm PT50x100x2.0mm
Stack	60kg (standard) 90kg (optional)
Steel cable	Φ 4.8 pu coated
Pulley	Φ 115 POM pulley



STRENGTH



ADJ.INCLINE BENCH	L105
Assemble size	145×59×42cm
Main frame tube size	Pt50×100×2.0mm
Stabilizertube	75×2.0mm
N.W/G.W(kg)	32kg/37kg

FLAT BENCH	L106
Assemble size	130×59.2×40cm
Main frame tube size	Pt50×100×2.0mm
Stabilizertube	Φ 75×2.0mm
N.W/G.W(kg)	18kg/21kg

ADJ.DECLINE BENCH	L107
Assemble size	157.6×59.2×92.6cm
Main frame tube size	Pt50×100×2.0mm
Stabilizertube	Φ 75×2.0mm
N.W/G.W(kg)	34kg/37kg

VERTICAL PLATE TREE	L111
Assemble size	74.4×55.6×91.4cm
Main frame tube size	Pt50×100×2.0mm
Stabilizertube	/
N.W/G.W(kg)	18kg/21kg



DUMBBELL RACK-3layers	L119
Assemble size	164.3×72.6×107.8cm
Main frame tube size	Pt50×100×2.0mm
QTY of dumbbells can be placed	10 pairs (20pcs)
N.W/G.W(kg)	58kg/61kg

DUMBBELL RACK-2layers	L110
Assemble size	242×69×81cm
Main frame tube size	Pt50×100×2.0mm
QTY of dumbbells can be placed	10 pairs (20pcs)
N.W/G.W(kg)	61kg/67kg

BARBELL MAST HOLDER- 9HOLES	L115
Assemble size	38.4×35×16.8cm
Main frame tube size	Pt50×100×2.0mm
Stabilizertube	Φ 75×2.0mm
N.W/G.W(kg)	9kg/10kg

BARBELL MAST HOLDER-6HOLES	L115B
Assemble size	35×26.4×16.8cm
Main frame tube size	Pt50×100×2.0mm
Stabilizertube	Φ 75×2.0mm
N.W/G.W(kg)	7kg/8kg

VERTICAL DUMBBELL RACK	L117
Assemble size	42.8×42.3×134.6cm
Main frame tube size	Pt50×100×2.0mm
Stabilizertube	Φ 75×2.0mm
N.W/G.W(kg)	24kg/26kg