

**MSL-FN series**

**SINGLE LONGITUDINAL MODE LASER**

All solid state single longitudinal mode laser is made features of ultra compact, long lifetime, low cost and easy operating, which is used in DNA sequencing, flow cytometry, cell sorting, optical instrument, spectrum analysis, interference, measurement, holography, physics experiment, etc.

**SPECIFICATIONS**

Wavelength (nm)	360±1	457±1	473±1
Output power (mW)	1-50	1-350	1-100
Power stability (rms, over 4 hours)	<1%, <2%, <3%	<2%, <3%, <5%	<2%, <3%, <5%
Transverse mode	TEM <sub>00</sub>	Near TEM <sub>00</sub>	TEM <sub>00</sub>
Longitudinal mode	Single		
Operating mode	CW		
Spectral line width (nm)	<0.00001		
Coherent length (m)	>50		
Noise of amplitude (rms, 1Hz~20MHz)	<0.5%, <1%	<0.5%, <1%	
M <sup>2</sup> factor	<1.5	<1.2	
Beam diameter at the aperture (1/e <sup>2</sup> , mm)	<1.2	<2.0	
Beam divergence, full angle (mrad)	<1.0	<1.2	
Polarization Ratio	>50:1 Horizontal±5 degree (Vertical Optional)	>100:1, Horizontal±5 degree (Vertical Optional)	
Warm-up time (minutes)	<10		
Pointing stability after warm-up (mrad)	<0.05		
Beam height from base plate (mm)	27.4		
Laser head consumption(W)	15 (typical) , <25 (40°C)		
Max. Laser Head Base plate Temp (°C)	50		
Operating Temperature (°C)	10-40		
Power supply (90-264VAC)	PSU-H-FDA		
Expected lifetime (hours)	10000		
Warranty	1 year		

**Note: The laser head needs to be used on a heat sink with good heat dissipation.**

**SPECIFICATIONS**

Wavelength (nm)	522±1	523.5±1	526.5±1	532±1	
Output power (mW)	1-100	1-100	1-100	100-200	200-400
Power stability (rms, over 4 hours)	<1%, <2%, <3%		<1%, <2%, <3%		<1%, <2%, <3% (0.5% Optional)
Transverse mode	TEM <sub>00</sub>				
Longitudinal mode	Single				
Operating mode	CW				
Spectral line width (nm)	<0.00001				
Coherent length (m)	>50				
Noise of amplitude (rms, 1Hz~20MHz)	<1%		<1%	<0.5% (0.25% Optional)	
M <sup>2</sup> factor	<1.5	<1.2		<1.2 (<1.1 Optional)	
Beam diameter at the aperture (1/e <sup>2</sup> , mm)	~2.0	<1.5			
Beam divergence, full angle (mrad)	<1.5	<1.2			
Polarization Ratio	>100:1, Horizontal±5 degree (Vertical Optional)				
Warm-up time (minutes)	<10				
Pointing stability after warm-up (mrad)	<0.05				
Beam height from base plate (mm)	27.4				
Laser head consumption(W)	15 (typical), <25 (40°C)				
Max. Laser Head Base plate Temp (°C)	50				
Operating Temperature (°C)	10-40				
Power supply (90-264VAC)	PSU-H-FDA				
Expected lifetime (hours)	10000				
Warranty	1 year				

**Note: The laser head needs to be used on a heat sink with good heat dissipation.**

**SPECIFICATIONS**

Wavelength (nm)	543±1	552±1	556±1	561±1
Output power (mW)	1-100	1-100	1-100	1-150
Power stability (rms, over 4 hours)	<1%, <2%, <3%	<2%, <3%, <5%	<1%, <2%, <3%, <5%	<1%, <2%, <3%, <5%
Transverse mode	TEM <sub>00</sub>	Near TEM <sub>00</sub>	TEM <sub>00</sub>	
Longitudinal mode	Single			
Operating mode	CW			
Spectral line width (nm)	<0.00001			
Coherent length (m)	>50			
Noise of amplitude (rms, 1Hz~20MHz)	<1%		<0.5%, <1%	
M <sup>2</sup> factor	<1.2	<1.2 (<1.1 Optional)		<1.2
Beam diameter at the aperture (1/e <sup>2</sup> , mm)	<1.5		<2.0	
Beam divergence, full angle (mrad)	<1.2		<1.2	
Polarization Ratio	>100:1, Horizontal±5 degree (Vertical Optional)			
Warm-up time (minutes)	<10			
Pointing stability after warm-up (mrad)	<0.05			
Beam height from base plate (mm)	27.4			
Laser head consumption(W)	15 (typical) , <25 (40°C)			
Max. Laser Head Base plate Temp (°C)	50			
Operating Temperature (°C)	10-40			
Power supply (90-264VAC)	PSU-H-FDA			
Expected lifetime (hours)	10000			
Warranty	1 year			

**Note: The laser head needs to be used on a heat sink with good heat dissipation.**

**SPECIFICATIONS**

Wavelength (nm)	588±2	589±1		607±1	639±1
Output power (mW)	1-200	1-100	100-200	1-100	1-300
Power stability (rms, over 4 hours)	<3%, <5%, <10%	<2%, <3%	<2%, <3%, <5%	<1%, <2%, <3%	<1%, <2%, <3%
Transverse mode	TEM <sub>00</sub>				
Longitudinal mode	Single				
Operating mode	CW				
Spectral line width (nm)	<0.00001				
Coherent length (m)	>50				
Noise of amplitude (rms, 1Hz~20MHz)	<0.5%, <1%			<1%	<0.5%, <1%
M <sup>2</sup> factor	<1.2				<1.2 (<1.1 Optional)
Beam diameter at the aperture (1/e <sup>2</sup> , mm)	<2.5			<1.5	
Beam divergence, full angle (mrad)	<1.2				<1.5
Polarization Ratio	>100:1, Horizontal±5 degree (Vertical Optional)				
Warm-up time (minutes)	<10				
Pointing stability after warm-up (mrad)	<0.05				6 μmrad/°C
Beam height from base plate (mm)	27.4				
Laser head consumption(W)	15 (typical) , <25 (40°C)				
Max. Laser Head Base plate Temp (°C)	50				
Operating Temperature (°C)	10-40				
Power supply (90-264VAC)	PSU-H-FDA				
Expected lifetime (hours)	10000				
Warranty	1 year				

**Note: The laser head needs to be used on a heat sink with good heat dissipation.**

**SPECIFICATIONS**

Wavelength (nm)	656.5±1	660±1	671±1
Output power (mW)	1-50	1-20	300-500
Power stability (rms, over 4 hours)	<1%, <3%, <5%	<3%, <5%	<2%, <3%
Transverse mode	TEM <sub>00</sub>		
Longitudinal mode	Single		
Operating mode	CW		
Spectral line width (nm)	<0.00001		
Coherent length (m)	>50		
Noise of amplitude (rms, 1Hz~20MHz)	<0.5%, <1%		
M <sup>2</sup> factor	<1.2		<1.2
Beam diameter at the aperture (1/e <sup>2</sup> , mm)	<2.0		<2.0 (<1.5 Optional)
Beam divergence, full angle (mrad)	<1.2		
Polarization Ratio	>100:1, Horizontal±5 degree (Vertical Optional)		
Warm-up time (minutes)	<10		
Pointing stability after warm-up (mrad)	<0.05		
Beam height from base plate (mm)	27.4		
Laser head consumption(W)	15 (typical) , <25 (40°C)		
Max. Laser Head Base plate Temp (°C)	50		
Operating Temperature (°C)	10-40		
Power supply (90-264VAC)	PSU-H-FDA		
Expected lifetime (hours)	10000		
Warranty	1 year		

**Note: The laser head needs to be used on a heat sink with good heat dissipation.**

Wavelength (nm)	698±1	721±1	
Output power (mW)	1-200	1-50	50-100
Power stability (rms, over 4 hours)	<1%,<2%,<3%	<3%,<5%	<3%,<5%,<10%
Transverse mode	TEM <sub>00</sub>		
Longitudinal mode	Single		
Operating mode	CW		
Spectral line width (nm)	<0.00001		
Coherent length (m)	>10	>50	
Noise of amplitude (rms, 1Hz~20MHz)	<0.5%, <1%		
M <sup>2</sup> factor	<1.2(<1.1 optional)	<1.2	
Beam diameter at the aperture (1/e <sup>2</sup> , mm)	<1.5		
Beam divergence, full angle (mrad)	<1.5	<1.2	
Polarization Ratio	>100:1, Horizontal±5 degree (Vertical Optional)		
Warm-up time (minutes)	<10		
Pointing stability after warm-up (mrad)	<0.05		
Beam height from base plate (mm)	27.4		
Laser head consumption(W)	15 (typical) , <25 (40°C)		
Max. Laser Head Base plate Temp (°C)	50		
Operating Temperature (°C)	10-40		
Power supply (90-264VAC)	PSU-H-FDA		
Expected lifetime (hours)	10000		
Warranty	1 year		

**Note: The laser head needs to be used on a heat sink with good heat dissipation.**

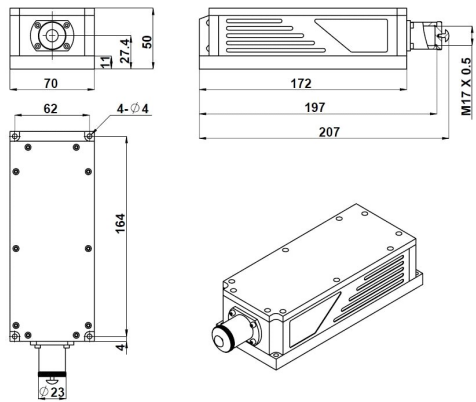
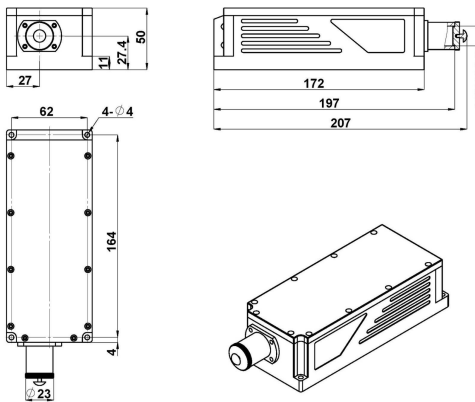
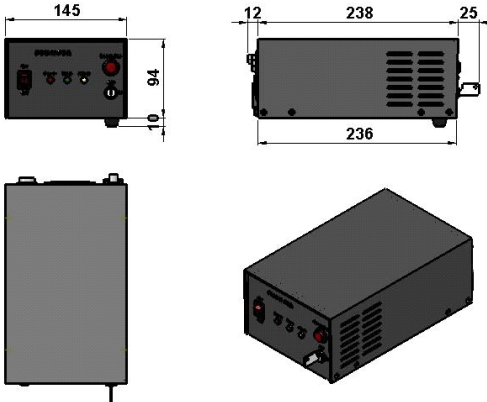
LASER HEAD	LASER HEAD (MSL-FN-360)	POWER SUPPLY
 <p data-bbox="352 795 588 820"><b>197(L)×70(W)×50(H) mm<sup>3</sup>, 1.5 kg</b></p>	 <p data-bbox="945 795 1180 820"><b>197(L)×70(W)×50(H) mm<sup>3</sup>, 1.5 kg</b></p>	 <p data-bbox="1522 795 1795 820"><b>275(L)×145(W)×104(H) mm<sup>3</sup>, 2.3 kg</b></p>