

**MGL-Z-532/30~60W**

**LD PUMPED ALL-SOLID-STATE GREEN LASER**

All Solid state 532nm green laser is made features of ultracompact, long lifetime and easy operating, which is widely used in collimation, laser medical treatment, scientific experiment, optical instrument, laser display, laser lighting show, etc.

**SPECIFICATIONS**

Wavelength (nm)	532±1
Operating mode	CW
Output power (W)	>30, 40, ..., 60
Power stability (rms, over 4 hours)	<1%, <2%, <3%, <5%
Transverse mode	Near TEM <sub>00</sub>
Beam divergence, full angle (mrad)	<2.0
Beam diameter at the aperture (1/e <sup>2</sup> , mm)	~4.5
Warm-up time (minutes)	<10
Beam height from base plate (mm)	91
Operating temperature (°C)	10~35
Power supply (90-264VAC)	PSU-SEP-W
TTL / Analog modulation	TTL or Analog with 1Hz-1kHz 1kHz-10kHz, 10kHz-30kHz optional
Expected lifetime (hours)	10000
Warranty period	1 year

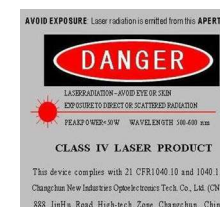
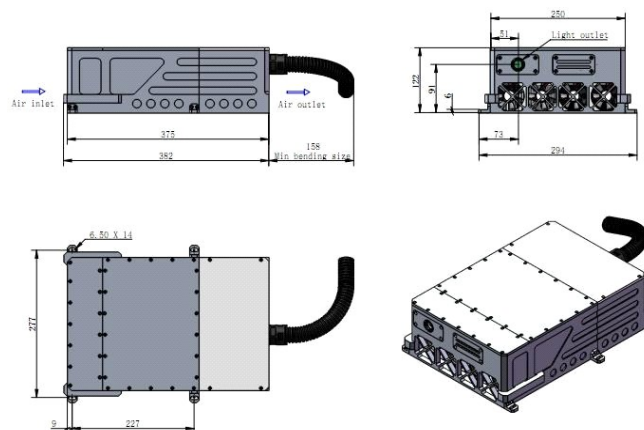
**MGL-Z-532**

382 (L) × 294 (W) × 122 (H) mm<sup>3</sup>, 10.7 kg

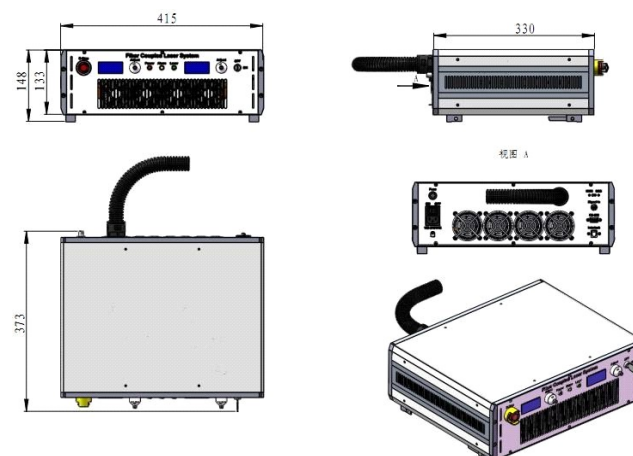
**PSU-SEP-W**

415 (L) × 373 (W) × 148 (H) mm<sup>3</sup>, 16 kg