

Rusty's HD Steering Conversion - JL Wrangler / JT Gladiator RS-SC9750-JLJT INSTALLATION INSTRUCTIONS

Last Revised: 12/12/2022

Introduction:

Rusty's recommends that this installation be performed by a certified automotive technician or a person with professional mechanical knowledge. Installing this kit without this expertise may jeopardize the handling and safety of the vehicle.

Read instructions several times before starting. Be sure you have all the needed parts and know where they install. Read each step completely as you go. Exhaust modifications may be necessary. Prior to drilling or cutting, check behind the surface being worked on for any wires, lines, or hoses that could be damaged. After any drilling or cutting, remove burrs and grind smooth any surfaces. An inclinometer or similar tool may be needed to measure driveshaft angles before and after the installation.

Warning:

- It is the owners' responsibility to inspect all Rusty's products for proper torque specs to prevent loosening of components.
- Seat belts and shoulder harnesses should be worn at all times.
- Re-check all bolts and nuts after the first 100 miles and after any off-road usage during the first 300 miles.
- Although all of our products are made from the highest quality materials possible, they are not a substitute for Safe and Careful driving. In other words, have good safe on-road / off-road sense. Know the terrain, the speed limitations, and any obstacles that may lie ahead. Please remember to preserve our right to enjoy public land through the proper use of off-road vehicles.

Before Starting Installation:

1. Carefully Read all warnings and instructions completely before beginning.
2. Verify all parts have been received in this kit by checking the parts list on page#2 of this document.
3. Only install this kit on the vehicle for which it is specified.
4. Park the vehicle on a clean, dry, flat, level surface and block the tires so the vehicle cannot roll in either direction.
5. Be certain the vehicle is safely secured on jack stands or a vehicle lift prior to working around or under a vehicle. Never rely on a jack alone to support a vehicle's weight; use appropriately rated stands to support the vehicle's frame and any other heavy components.

Parts List:

Note: Please be sure that you have all the provided parts listed below before continuing with the installation.

Part #	DESCRIPTION:	Quantity
RS-DL9710-JLJT	Rusty's Drag Link - HD Replacement (JL/JT) (Contents Listed Below)	1
RS-DLTUBE-JLJT	Rusty's Drag Link - HD Replacement Tube (JL/ JT)	1
RS-TR18015-JLJT	Rusty's HD JL/JT Drag Link Replacement Tie Rod End - Left Hand Thread	1
RS-TR18016-JLJT	Rusty's HD JL/JT Drag Link Replacement Tie Rod End - Right Hand Thread	1
JN114SC-LH	Rusty's Jam Nut - 1-1/4"- Left Hand Thread	1
JN114SC-RH	Rusty's Jam Nut - 1-1/4"- Right Hand Thread	1
S30ZC	Serrated Lock Washer	2

Part #	DESCRIPTION:	Quantity
RS-TR9720-JLJT	Rusty's Tie Rod - HD Replacement (JL/JT) (Contents Listed Below)	1
RS-TRTUBE-JLJT	Rusty's Tie Rod - HD Replacement Tube (JL/JT)	1
RS-TR18017-JLJT	Rusty's HD JL/JT Tie Rod Replacement Tie Rod End - Left Hand Thread	1
RS-TR18018-JLJT	Rusty's HD JL/JT Tie Rod Replacement Tie Rod End - Right Hand Thread	1
JN114SC-LH	Rusty's Jam Nut - 1-1/4"- Left Hand Thread	1
JN114SC-RH	Rusty's Jam Nut - 1-1/4"- Right Hand Thread	1
S30ZC	Serrated Lock Washer	2
RS6996-JLJT	RS-SC9750-JLJT Replacement Wiper Seal	2

Part #	DESCRIPTION:	Quantity
RS-TRC175-UV	Rusty's 1.75" Diameter Tie Rod Clamp Ram / Stabilizer Mount	1

Parts List continued on next Page 3.

Parts List:

Note: Please be sure that you have all the provided parts listed below before continuing with the installation.

Part #	DESCRIPTION:	Quantity
RS-SSM0718	Rusty's Steering Stabilizer Raised Axle Side Relocation Mount (JK/JL/JT) (Contents Listed Below)	1
91959874	M14 x 2.00mm x 90mm Length Hex Head Cap Screw	1
67493163	M14 x 28mm O.D. Flat Washer	2
67486084	M14 x 2mm Hex Lock Nut	1
67445684	M12 x 1.75mm x 75mm Length Hex Head Cap Screw	1
67746685	1/2" SAE Flat Washer	2
67486043	M12 x 1.75mm Grade 8 Hex Lock Nut	1
87915179	3/8"-16 x 1" Length Grade 8 Hex Head Cap Screw	1
67746602	3/8" x 13/32" O.D. SAE Flat Washer	1
87922050	3/8" - 16 Grade 8 Hex Lock Nut (Silver Finish)	1

Rusty's HD JL/JT Steering Conversion Components

Note: Please be sure that you have all the provided parts listed below before continuing with the installation.

Rusty's Drag Link - HD Replacement (JL/JT 18-Current)

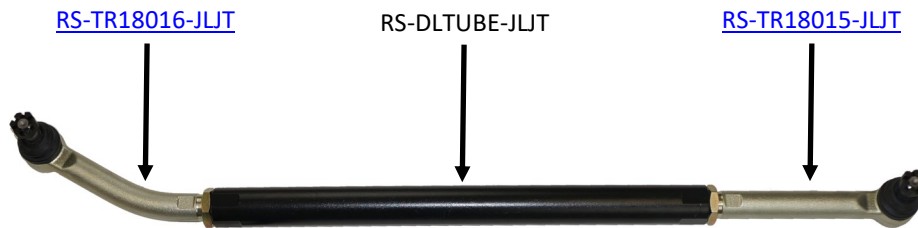

Rusty's Tie Rod - HD Replacement (JL/JT 18-Current)

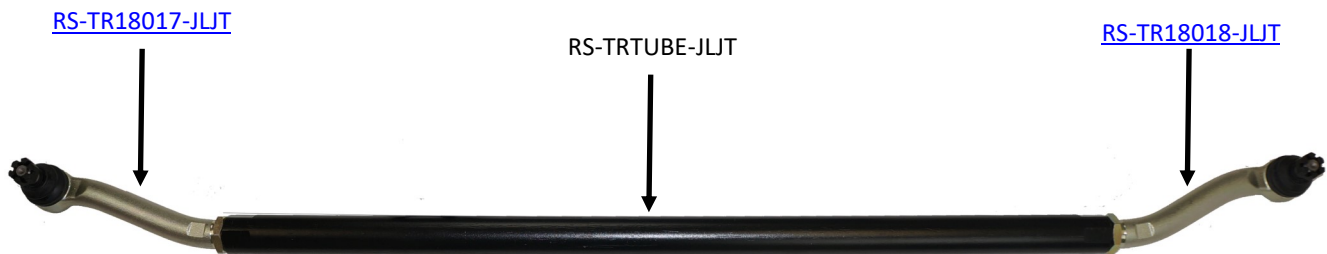

Rusty's HD JL/JT Tie Rod Steering Stabilizer Mount

Rusty's HD JK Tie Rod Steering Stabilizer Mount

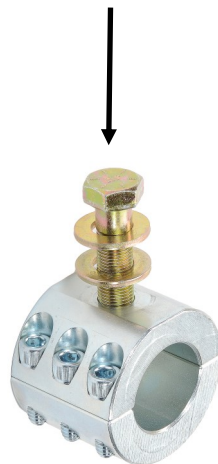

Installation Instructions

Note: Save all factory components and hardware for reuse, unless noted.

1. Remove the steering stabilizer from the tie rod and move it out of the way.
2. Remove the 4 factory nuts that attach the factory tie rod ends to the steering knuckles and the pitman arm.
3. Typically you will have to tap the tie rod ends out of the knuckles and pitman arm with a hammer or similar tool.
4. Remove the factory tie rod and drag link assemblies.
5. With the factory tie rod and drag link assemblies removed from the vehicle install the supplied Rusty's Steering Stabilizer Mount following the listed steps below. (Please Note: If you are using our Pass Through Steering Stabilizer Mount you can skip to step # 6.)
 - A. Remove the track bar bolt and nut on the axle side.
 - B. Align the supplied steering stabilizer relocation mount and install the supplied 14mm hardware to hole into position.
 - C. Line up and level the bracket and use a center punch to mark the hole location to drill the hole location marked in the diagram below for the JL Wrangler / JT Gladiator models.
 - D. Drill the center punched hole location to a 3/8" hole. It is suggested to start with a pilot drill hole of 1/8" then step up to 3/8".
 - E. Secure the bracket to the axle and reinstall the track bar at this time using the supplied hardware as marked below.

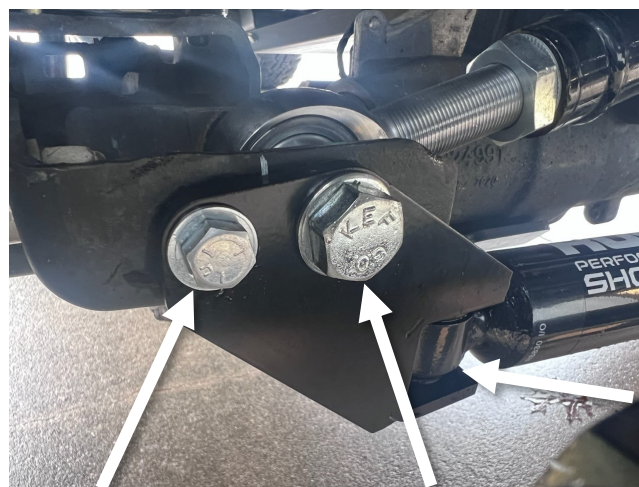

3/8" Hardware

14mm Hardware

12mm Hardware

Installation Instructions

Note: Save all factory components and hardware for reuse, unless noted.

6. Measure the center to center length on the factory tie rod end to end and adjust the new tie rod assembly to the same length, then tighten the jam nuts. Make sure to apply anti seize or grease when threading ends into tie rod bar. (**Note:** This is a starting point to get your jeep to alignment shop for a proper alignment. If your factory steering is bent or damaged this method will be off.)

IMPORTANT NOTE:

Installed the supplied serrated lock washers as illustrated in the image below.

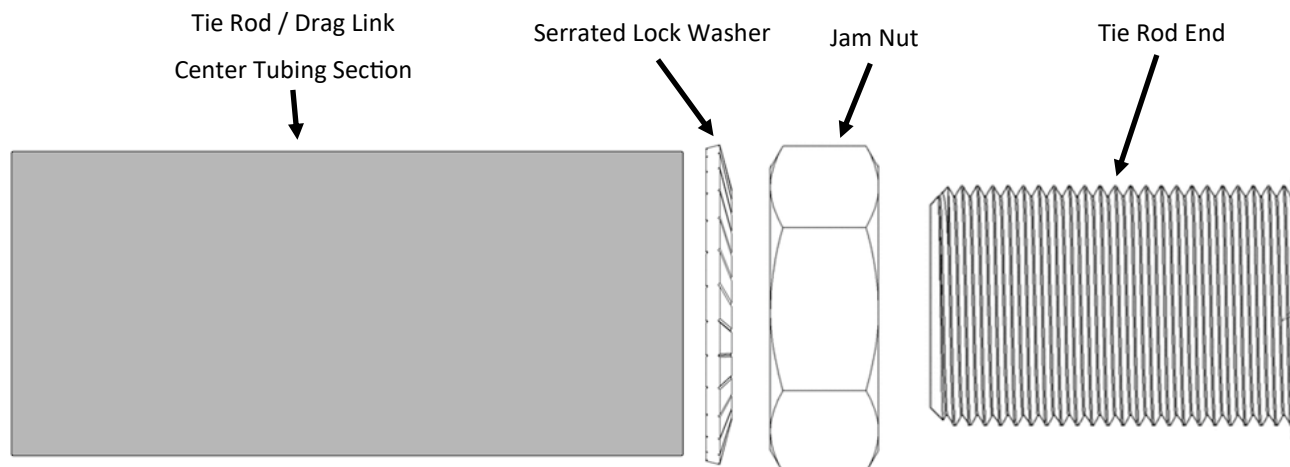

7. Repeat the same process in Step #6 for the new drag link assembly. (**Note:** This is a starting point to get your jeep to alignment shop for a proper alignment. If your factory steering is bent or damaged this method will be off.)

Installation Instructions

Note: Save all factory components and hardware for reuse, unless noted.

8. Install the tie rod and draglink into the same position as the old components came out of your stock steering configuration. Before installing the tie rod bar assembly, install the supplied Wiper Seals by removing the dust boots on the tie rod ends of the tie rod bar only. Make sure to leave the dust boots on drag link tie rod ends.

IMPORTANT NOTE:

Please note that the supplied wiper seals are to be installed
ONLY on the **Tie Rod Ends on the Tie Rod Bar Assembly.**

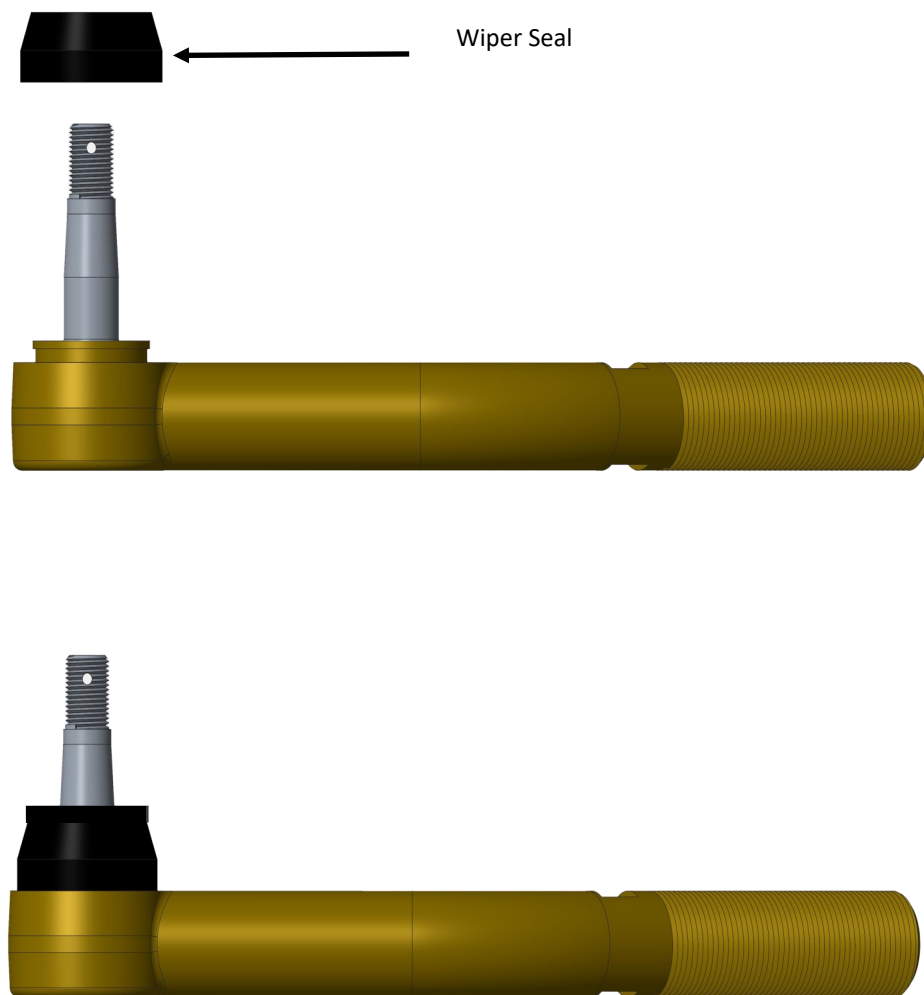

Installation Instructions

Note: Save all factory components and hardware for reuse, unless noted.

9. After you have positioned the tie rod and drag link assemblies into place. You will need to tighten the tie rod ends and drag link ends nylon lock nuts to following torque specs. Torque the end at the Pitman Arm to 75 ft. lbs. and tighten the remain ends at the Steering Knuckles to 65 ft.lbs.
10. Now that both assemblies are in place double check your measurements and tighten the jam nuts to 150 ft.lbs.
11. Reinstall the steering stabilizer using the supplied Rusty's HD Tie Rod Steering Stabilizer Mount. To install the shock turn the wheels all the way right and hold it there. Compress the steering stabilizer all the way, Pull it out and 1/8" and then clamp it to the tie rod tubing using supplied bracket. Torque the nuts to 18 ft. lbs. You will reused the factory bolt that attached the steering stabilizer to the tie rod assembly. (Please Note: If you purchased the Pass Through Steering Stabilizer Mount you can to the Passenger Side Tie Rod End as shown in Image# 2)

Image #1 (Rusty's Clamp Style Steering Stabilizer Mount)



Image #2 (Rusty's Pass-Through Steering Stabilizer Mount)

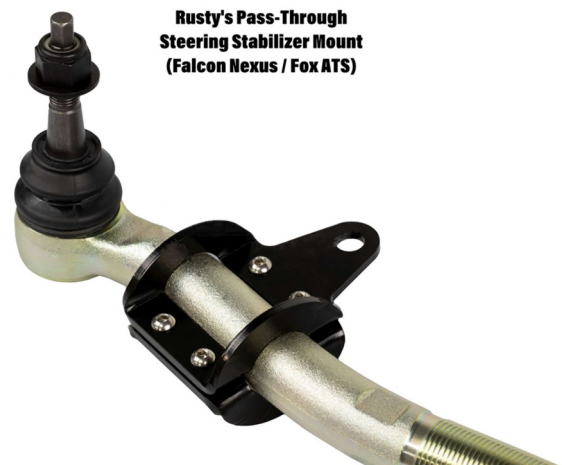

12. Before driving grease the tie rod ends with a grease gun.
13. Double check and make sure that the steering wheel is centered before driving as well. If not centered you will need to adjust the draglink until the steering wheel is centered.
14. Installation is now complete!

Final Notes

At this point there should be no parts left but installing the stickers. The vehicle will need to have an alignment as soon as possible, if you don't you may get the "death wobble", poor tire wear or just a bad handling vehicle.

Alignment Recommended Specifications

- Toe: Should be set at 0 to 1/32" Toe Out
- Castor: +7 Degrees Positive
- Camber: 0 Degrees

Re-torque all fasteners after 500 miles and recheck after 1000 miles. Visually inspect components and re-torque fasteners during routine vehicle service.

WARNING

It is the owners' responsibility to inspect all Rusty's products for proper torque specs to prevent loosening of components. Seat belts and shoulder harnesses should be worn at all times. Re-check all bolts and nuts after the first 300 miles and after any off-road usage during the first 300 miles. Although all of our products are made from the highest quality materials possible, they are not a substitute for Safe and Careful driving. In other words, have good safe on-road / off-road sense. Know the terrain, the speed limitations, and any obstacles that may lie ahead. Please remember to preserve our right to enjoy public land through the proper use of off-road vehicles. Thank you for choosing Rusty's Off Road Products.