

## Rusty's JK 2 Door Rocker Sliders RA-RP2D INSTALLATION INSTRUCTIONS

Last Revised: 2/12/2019

### Introduction:

Rusty's recommends that this installation be performed by a certified automotive technician or a person with professional mechanical knowledge. Installing this kit without this expertise may jeopardize the handling and safety of the vehicle.

Read instructions several times before starting. Be sure you have all the needed parts and know where they install. Read each step completely as you go. Exhaust modifications may be necessary. Prior to drilling or cutting, check behind the surface being worked on for any wires, lines, or hoses that could be damaged. After any drilling or cutting, remove burrs and grind smooth any surfaces. An inclinometer or similar tool may be needed to measure driveshaft angles before and after the installation.

### Warning:

- It is the owners' responsibility to inspect all Rusty's products for proper torque specs to prevent loosening of components.
- Seat belts and shoulder harnesses should be worn at all times.
- Re-check all bolts and nuts after the first 100 miles and after any off-road usage during the first 300 miles.
- Although all of our products are made from the highest quality materials possible, they are not a substitute for Safe and Careful driving. In other words, have good safe on-road / off-road sense. Know the terrain, the speed limitations, and any obstacles that may lie ahead. Please remember to preserve our right to enjoy public land through the proper use of off-road vehicles.

### Before Starting Installation:

1. Carefully Read all warnings and instructions completely before beginning.
2. Verify all parts have been received in this kit by checking the parts list on page#2 of this document.
3. Only install this kit on the vehicle for which it is specified.
4. Park the vehicle on a clean, dry, flat, level surface and block the tires so the vehicle cannot roll in either direction.
5. Be certain the vehicle is safely secured on jack stands or a vehicle lift prior to working around or under a vehicle. Never rely on a jack alone to support a vehicle's weight; use appropriately rated stands to support the vehicle's frame and any other heavy components.

## Parts List:

**Note:** Please be sure that you have all the provided parts listed below before continuing with the installation.

<b>Part #</b>	<b>DESCRIPTION:</b>	<b>Quantity</b>
RA-RP2D-DS	Quarter Panel Guard, Driver Side	1
RA-RP2D-PS	Quarter Panel Guard, Passenger Side	1
67563122	1/4"-20 x 1" Length Button Head Cap Screw	18
67563080	1/4"-20 x 3/4 Length Button Head Cap Screw	12
08411266	1/4"-20 Knurled Threaded Nut Insert	18
67483362	1/4"-20 Serrated Flange Nut	12
09331745	1/4"-20 UNC Manual Threaded Insert Installation Tool	1
87920112	1/4" Flat Fender Washer	12

## Installation Instructions

**Note:** Save all factory components and hardware for reuse, unless noted.

1. Remove "Unlimited" or "Wrangler" decals from driver and passenger side body. They will be obscured by kit rocker panels.



2. With the help of an assistant, prepare the mounting points by positioning the armor into position. (**Note:** Be sure the door lines match up with the profile of the armor.)
3. Once satisfied with the position of the armor, mark the centers of the hole locations in the armor. (**Note:** We recommend using a transfer punch to mark all of the hole locations.)

## Installation Instructions (Continued)

4. Use the corresponding illustration on page# 3 and drill all of the locations to the correct size. (Note: Use caution not to drill any hole locations any deeper than 1".) (Note: Some hole locations will have to drill through two layers of metal for the 1/4"-20 Knurled Threaded Nut Inserts to slide flush with the body.)
5. Loosen the (Qty: 4) front fender bolts as illustrated in the image below. (Note: If the Jeep is equipped with factory rock rails, they must be removed to get to both of the outer lower fender bolts.)



6. Install the 1/4"-20 Knurled Threaded Nut Inserts using the provided 1/4"-20 UNC Manual Threaded Insert Installation Tool into all of the 3/8" holes you previously drilled in step# 4. (Note: Use the supplied instructions that are packaged with the 1/4"-20 UNC Manual Threaded Insert Installation Tool.)
7. With the (Qty:4) Lower Fender Bolts loosened from step# 5, align the armor with the 5/16" holes you drilled from step# 4. Once aligned you will use the supplied hardware as labeled on Page#3. (Note: You will need to pull the fender away from the jeep to gain access to the rear of the panel to install the 1/4" Flat Fender Washers and 1/4"-20 Serrated Flange Nut.) (Note: Do not fully tighten any hardware until instructed to do so.)
8. Install the 1/4"-20 x 1" Length Button Head Cap Screws into the hole locations where you installed the 1/4"-20 Knurled Threaded Nut Inserts or the remaining hole locations to the rear side of the armor. (Note: We suggest starting all of these fasteners by hand to prevent cross threading.)
9. Tighten all of the hardware. (Note: We recommend tightening hardware in a cross-diagonal pattern.)
10. Repeat Steps on the opposite side of the vehicle.
11. Installation Completed!

## RA-RP4D Installation Diagram

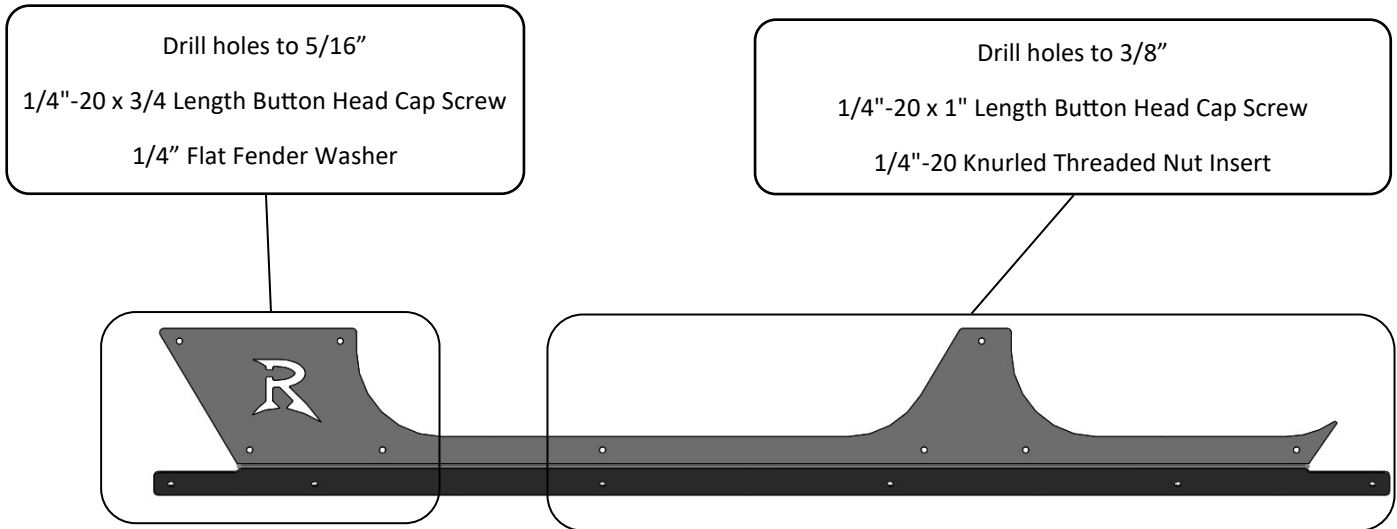

## RA-RP2D Installation Diagram

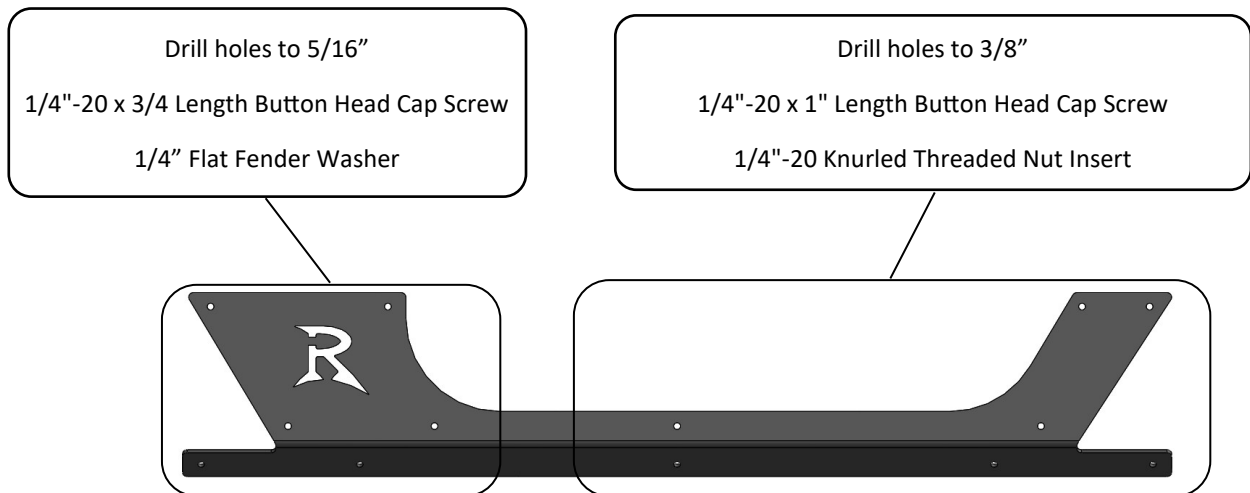

## WARNING

It is the owners' responsibility to inspect all Rusty's products for proper torque specs to prevent loosening of components. Seat belts and shoulder harnesses should be worn at all times. Re-check all bolts and nuts after the first 300 miles and after any off-road usage during the first 300 miles. Although all of our products are made from the highest quality materials possible, they are not a substitute for Safe and Careful driving. In other words, have good safe on-road / off-road sense. Know the terrain, the speed limitations, and any obstacles that may lie ahead. Please remember to preserve our right to enjoy public land through the proper use of off-road vehicles. Thank you for choosing Rusty's Off Road Products.