



Rusty's Off-Road Products  
7161 Steele Station Road  
Rainbow City, AL 35906  
1-256-442-0607  
[www.rustysoffroad.com](http://www.rustysoffroad.com)

## Rusty's JK Inner Fenders RA-MF4500-JK INSTALLATION INSTRUCTIONS

Last Revised: 01/17/2017

### Introduction:

Rusty's recommends that this installation be performed by a certified automotive technician or a person with professional mechanical knowledge. Installing this kit without this expertise may jeopardize the handling and safety of the vehicle.

Read instructions several times before starting. Be sure you have all the needed parts and know where they install. Read each step completely as you go. Exhaust modifications may be necessary. Prior to drilling or cutting, check behind the surface being worked on for any wires, lines, or hoses that could be damaged. After any drilling or cutting, remove burrs and grind smooth any surfaces. An inclinometer or similar tool may be needed to measure driveshaft angles before and after the installation.

### Warning:

- It is the owners' responsibility to inspect all Rusty's products for proper torque specs to prevent loosening of components.
- Seat belts and shoulder harnesses should be worn at all times.
- Re-check all bolts and nuts after the first 100 miles and after any off-road usage during the first 300 miles.
- Although all of our products are made from the highest quality materials possible, they are not a substitute for Safe and Careful driving. In other words, have good safe on-road / off-road sense. Know the terrain, the speed limitations, and any obstacles that may lie ahead. Please remember to preserve our right to enjoy public land through the proper use of off-road vehicles.

### Before Starting Installation:

1. Carefully Read all warnings and instructions completely before beginning.
2. Verify all parts have been received in this kit by checking the parts list on page#2 of this document.
3. Only install this kit on the vehicle for which it is specified.
4. Park the vehicle on a clean, dry, flat, level surface and block the tires so the vehicle cannot roll in either direction.
5. Be certain the vehicle is safely secured on jack stands or a vehicle lift prior to working around or under a vehicle. Never rely on a jack alone to support a vehicle's weight; use appropriately rated stands to support the vehicle's frame and any other heavy components.



For Questions or Suggestions, contact our Tech Department (256-442-0607)

**Parts List:**

**Note:** Please be sure that you have all the provided parts listed below before continuing with the installation.

<b>Part #</b>	<b>DESCRIPTION:</b>	<b>Quantity</b>
RA-MF4500-JK-DSU	Rusty's JK Front Driver's Side Upper Inner Fender Panel	1
RA-MF4500-JK-DSL	Rusty's JK Front Driver's Side Lower Inner Fender Panel	1
RA-MF4500-JK-PSU	Rusty's JK Front Passenger's Side Upper Inner Fender Panel	1
RA-MF4500-JK-PSL	Rusty's JK Front Passenger's Side Lower Inner Fender Panel	1
67381681	#12 x 1" Length Self Drilling Screw	4
67563080	1/4"-20 x 3/4 Length Button Head Cap Screw	6
68017805	M6-1.00 x 20mm Long 18-8 Button Head Cap Screw	6
87920112	1/4" x 1" O.D. Fender Washer	4
08411266	1/4"-20 Knurled Threaded Nut Insert	2
09331745	1/4"-20 UNC Manual Threaded Insert Installation Tool	1

**Assembly Illustration**

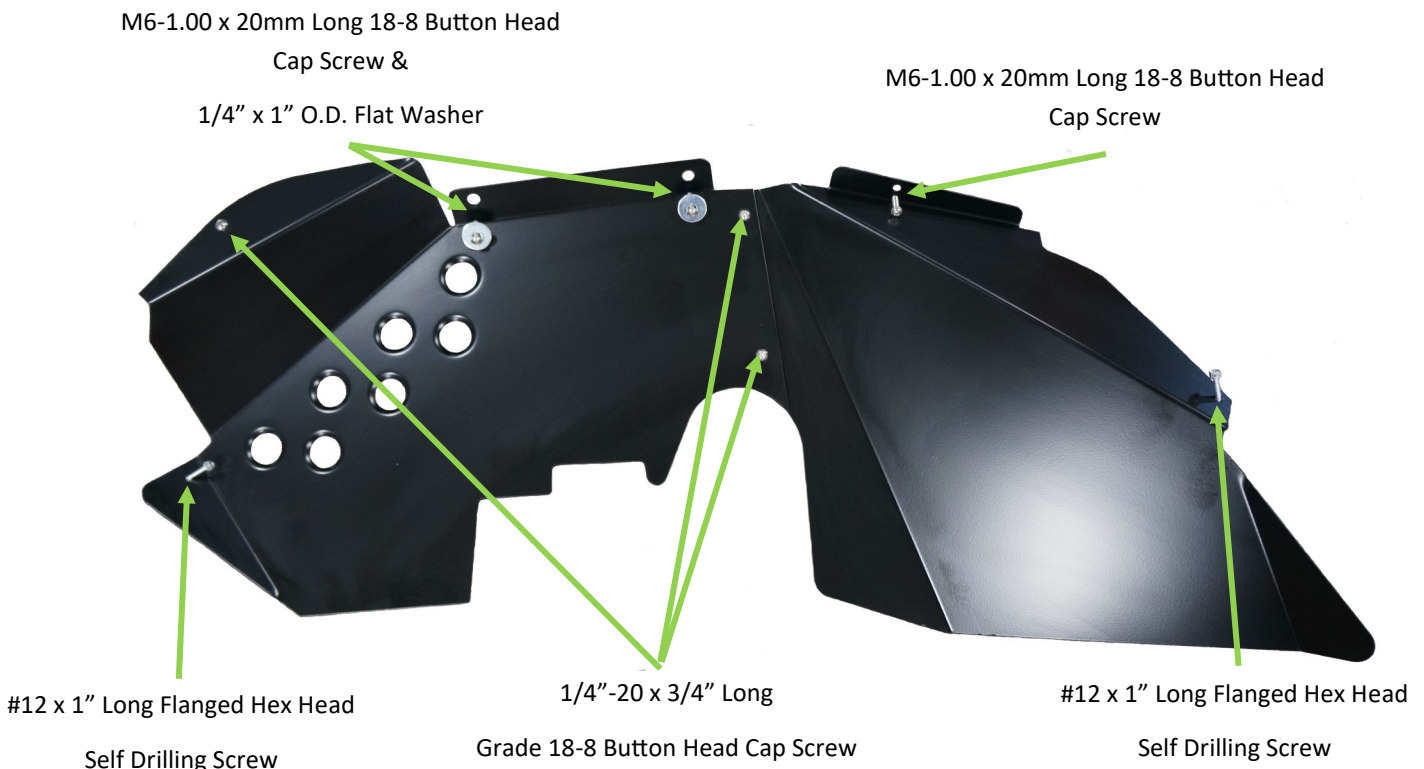

For Questions or Suggestions, contact our Tech Department (256-442-0607)

## Installation Instructions

Note: Perform the following steps one side at a time. Save all factory components and hardware for reuse, unless noted.

- 1.) Remove the factory fender liner assembly by unscrewing all of the 10mm bolts from the liner area. Remove the push-in rivets on the lower portion of the liner to release it from the Jeep. Lift up on the fender to separate them from the snap-in clips on the body.
- 2.) This would be a good time to clean the exposed area before continuing with the installation.
- 3.) Remove the clip-on nut from the body. This will be located at the front of the fender, just above the first of the snap-in clips that held the fender flare in place. Install the 1/4"x20 threaded insert in the position where the clip-on nut was removed using the supplied installation tool.



- 4.) Place the rear liner panel into position and start the M6-1.00 x 20mm button head allen bolt at the top mounting point. Do not tighten at this time.
- 5.) Insert the front inner fender panel into position and start the (Qty:2) M6-1.00 x 20mm button head allen bolts with the supplied 1/4"x1" O.D. fender washers at the top mounting points. Do not tighten at this time.
- 6.) Install the (Qty:2) 1/4"-20 x 3/4" button head allen bolts to attach the front and rear inner fender liners to each other. Do not tighten at this time.
- 7.) Install the 1/4"-20 x 3/4" button head allen bolt at the front most upward mounting point where the threaded insert was previously installed. Do not tighten at this time.
- 8.) Tighten the (Qty:3) 6mm-1.00 x 20mm button head allen bolts at the top of the inner fender panel, then loosen them each one full rotation.
- 9.) Align the two inner fender panels to ensure they sit flush where they connect together. Once aligned, tighten the (Qty:2) 1/4"-20 x 3/4" button head allen bolts that attach the front and rear panels together.
- 10.) Fully tighten the (Qty:3) 6mm-1.00 x 20mm button head allen bolts from Step # 8.

### Installation Instructions

11.) Locate the rear mounting point where the inner fender panel mounts to the body's pinch weld seam. Press firmly against the inner fender panel, making sure it fits flush against the body's pinch weld seam. Using a 5/16" x 6" extended nut driver, screw the #12 x 1" screw in place. (Do not Over Tighten)



12.) Locate to the front mounting point where the inner fender mounts to the body mount bracket. Press firmly against the inner fender panel to make sure it sits flush against the body mount bracket. Using a 5/16" x 6" extended nut driver, screw the #12 x 1" screw in place. (Do not Over Tighten)



13.) Fully tighten the 1/4"-20 x 3/4" allen head bolt that is installed where the threaded nut insert was installed in step # 3.



## Installation Instructions

- 14.) Repeat the Steps 1-13 on the other side of the vehicle.
- 15.) Double-check all fasteners for proper torque and all components for proper clearances and operation.
- 16.) Installation is now complete.

## WARNING

It is the owners' responsibility to inspect all Rusty's products for proper torque specs to prevent loosening of components. Seat belts and shoulder harnesses should be worn at all times. Re-check all bolts and nuts after the first 300 miles and after any off-road usage during the first 300 miles. Although all of our products are made from the highest quality materials possible, they are not a substitute for Safe and Careful driving. In other words, have good safe on-road / off-road sense. Know the terrain, the speed limitations, and any obstacles that may lie ahead. Please remember to preserve our right to enjoy public land through the proper use of off-road vehicles. Thank you for choosing Rusty's Off Road Products.



For Questions or Suggestions, contact our Tech Department (256-442-0607)