

## Rusty's Factory Front Bumper Skid Plate- JL Wrangler

RA-JS9555-JL

### INSTALLATION INSTRUCTIONS

Last Revised: 1/18/2019

#### Introduction:

Rusty's recommends that this installation be performed by a certified automotive technician or a person with professional mechanical knowledge. Installing this kit without this expertise may jeopardize the handling and safety of the vehicle.

Read instructions several times before starting. Be sure you have all the needed parts and know where they install. Read each step completely as you go. Exhaust modifications may be necessary. Prior to drilling or cutting, check behind the surface being worked on for any wires, lines, or hoses that could be damaged. After any drilling or cutting, remove burrs and grind smooth any surfaces. An inclinometer or similar tool may be needed to measure driveshaft angles before and after the installation.

#### Warning:

- It is the owners' responsibility to inspect all Rusty's products for proper torque specs to prevent loosening of components.
- Seat belts and shoulder harnesses should be worn at all times.
- Re-check all bolts and nuts after the first 100 miles and after any off-road usage during the first 300 miles.
- Although all of our products are made from the highest quality materials possible, they are not a substitute for Safe and Careful driving. In other words, have good safe on-road / off-road sense. Know the terrain, the speed limitations, and any obstacles that may lie ahead. Please remember to preserve our right to enjoy public land through the proper use of off-road vehicles.

#### Before Starting Installation:

1. Carefully Read all warnings and instructions completely before beginning.
2. Verify all parts have been received in this kit by checking the parts list on page#2 of this document.
3. Only install this kit on the vehicle for which it is specified.
4. Park the vehicle on a clean, dry, flat, level surface and block the tires so the vehicle cannot roll in either direction.
5. Be certain the vehicle is safely secured on jack stands or a vehicle lift prior to working around or under a vehicle. Never rely on a jack alone to support a vehicle's weight; use appropriately rated stands to support the vehicle's frame and any other heavy components.

**Parts List:**

**Note:** Please be sure that you have all the provided parts listed below before continuing with the installation.

<b>Part #</b>	<b>DESCRIPTION:</b>	<b>Quantity</b>
RA-JS9555-JL	Rusty's Factory Front Bumper Skid Plate- JL Wrangler	1
RA-JS9555-JL-38L-TN	Rusty's 3/8" "L" Shaped Tab Nut	2
RA-JS9555-JL-38T-TN	Rusty's 3/8" "T" Shaped Tab Nut	2
74454620	3/8"-16 x 1-1/4" Length Grade 8 Hex Head Cap Screw	4
05724620	3/8" SAE Flat Washer	4

**Removal Instructions for Plastic Front Bumpers (Sport and Sahara Models)**

**Note:** Save all factory components and hardware for reuse, unless noted.

1. Remove the factory plastic front bumper air dam
  - a. Remove (Qty:8) Plastic Push Rivets that attach the air dam to the bottom side of the front bumper.
  - b. Remove the (Qty:2) Factory Bolts that hold the back side of the front bumper air dam to the frame.
2. Remove the factory skid plate support panel.
  - a. Remove the (Qty:2) factory bolts holding the skid plate support panel to remove, do not discard the hardware. The hardware at will be reused. (**Note:** The skid plate support panel will no long be used.)

**Removal Instructions for Steel Front Bumpers (Rubicon)**

**Note:** Save all factory components and hardware for reuse, unless noted.

1. Remove the factory metal skid plate from the front bumper.
  - a. Remove (Qty:5) 13mm bolts that attach the skid plate to the bottom side of the front bumper.
  - b. Remove (Qty:2) 13mm bolts that attach the skid plate to the frame.

**Important Note: (All Models)**

**Note:** Please note that from this point going forward with the installation you will need to complete the steps for both the driver and passenger side of the vehicle.

## Important Note: (All Models)

**Note:** Please note that from this point going forward with the installation you will need to complete the steps for both the driver and passenger side of the vehicle.

## Installation Instructions for Plastic Front Bumpers (Sport and Sahara Models)

1. Install the supplied Rusty's Factory JL Wrangler Front Bumper Skid Plate by holding it in position and install the factory hardware retained when removing the factory skid plate support panel as shown in the image below. The illustration below is only of the driver side portion of the skid installation. Repeat all the steps on the passenger side when completing the driver side.

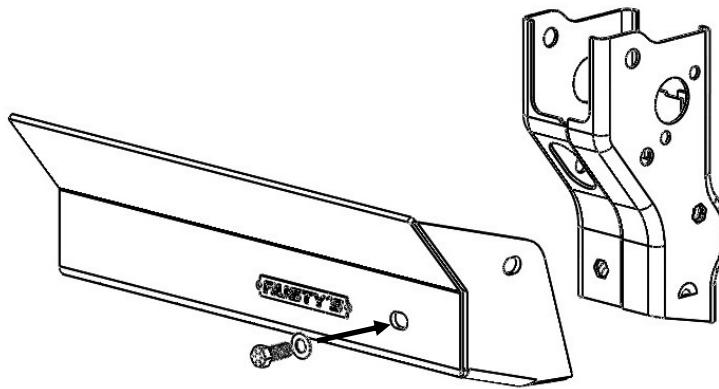

## Installation Instructions for Steel Front Bumpers (Rubicon Models)

1. Insert the supplied Rusty's Factory JL Wrangler Front Bumper Skid Plate 3/8" "L" Shaped Tab Nuts (Qty:2) through the bottom opening in the frame and align the hole with the factory hole located in the front of the frame as illustrated below.

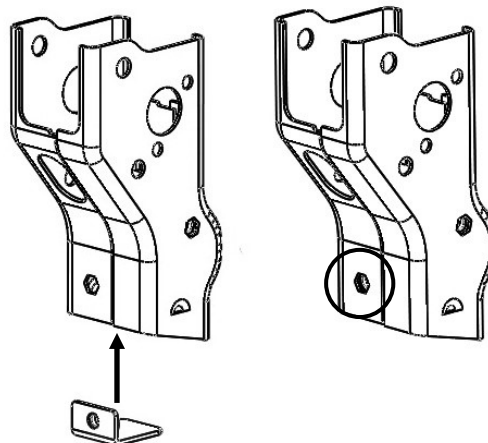

## **Installation Instructions for Steel Front Bumpers (Rubicon Models) (Continued)**

2. Install the supplied Rusty's Factory JL Wrangler Front Bumper Skid Plate by holding it in position and install the supplied 3/8"-16 x 1-1/4" Length Grade 8 Hex Head Cap Screws (Qty:2) and 3/8" SAE Flat Washers (Qty:2) to secure the skid to the frame as shown in the image below.

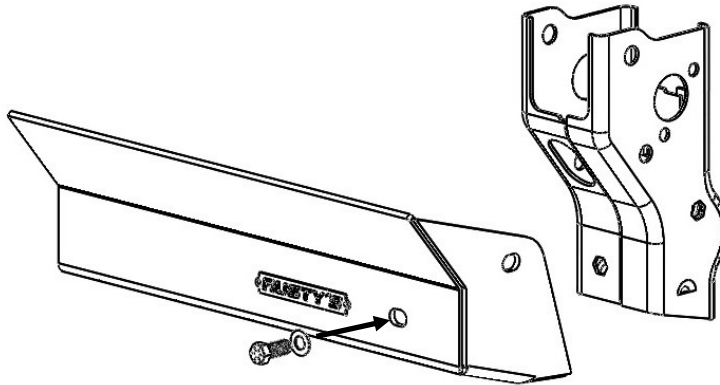

## **Installation Instructions for Both Steel and Plastic Front Bumpers (All Models)**

Note: The remaining installation process will be the same for all models from this point onward

1. Install the supplied Rusty's 3/8" "T" Shaped Tab Nuts (Qty:2) by inserting through the round opening in the frame rail and aligning the nut with the hole location in the skid plate as shown in the illustration below.

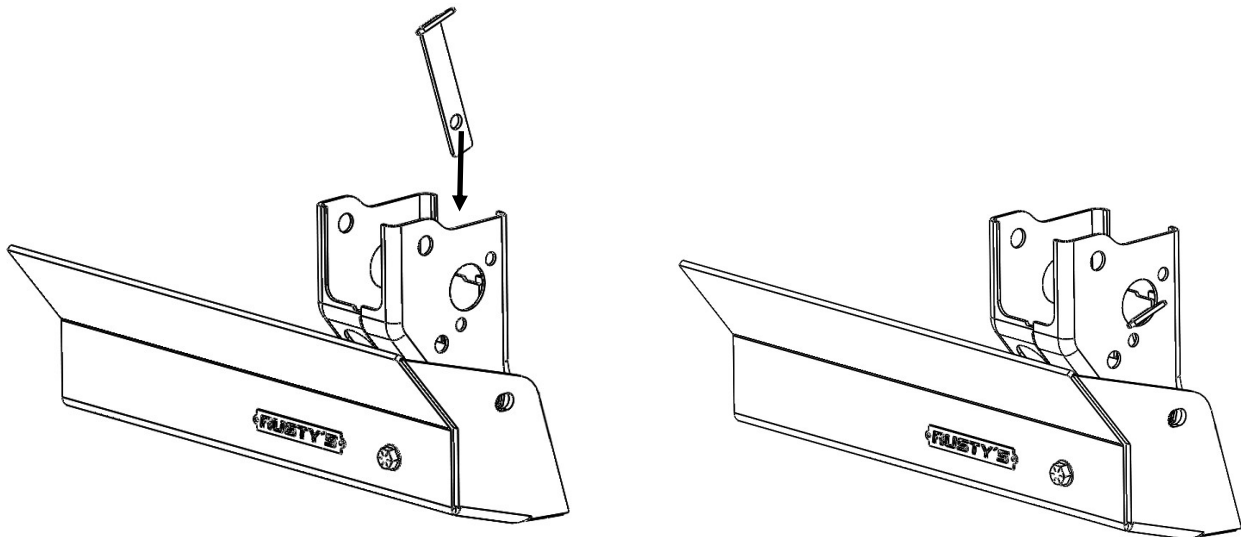

## Installation Instructions for Both Steel and Plastic Front Bumpers (All Models)

2. Install the supplied 3/8"-16 x 1-1/4" Length Grade 8 Hex Head Cap Screws (Qty:2) and 3/8" SAE Flat Washers (Qty:2) to the 3/8" "T" Shaped Tab Nuts installed in the previous step as shown in the image below.

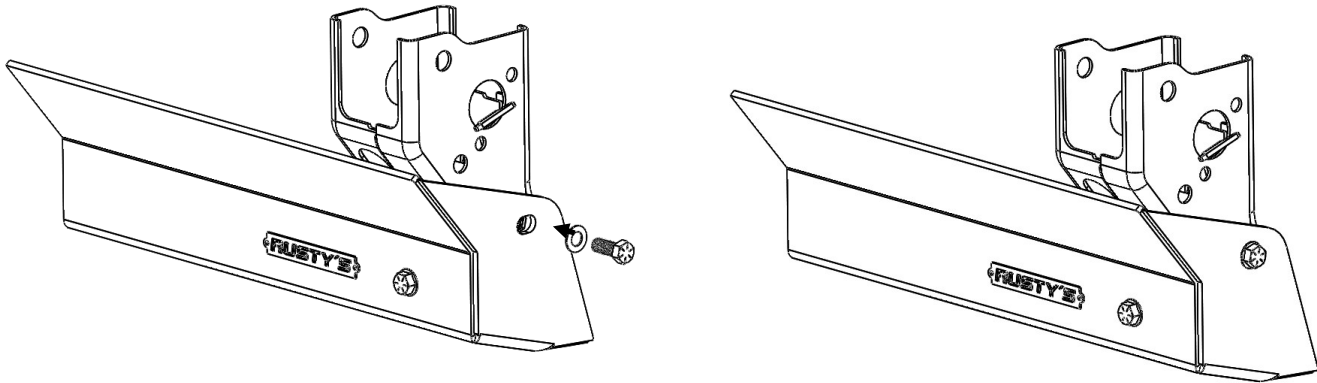

3. With all the hardware installed it is suggested to tighten all hardware to 45 ft.-lbs.
4. Installation is now completed!

## WARNING

It is the owners' responsibility to inspect all Rusty's products for proper torque specs to prevent loosening of components. Seat belts and shoulder harnesses should be worn at all times. Re-check all bolts and nuts after the first 300 miles and after any off-road usage during the first 300 miles. Although all of our products are made from the highest quality materials possible, they are not a substitute for Safe and Careful driving. In other words, have good safe on-road / off-road sense. Know the terrain, the speed limitations, and any obstacles that may lie ahead. Please remember to preserve our right to enjoy public land through the proper use of off-road vehicles. Thank you for choosing Rusty's Off Road Products.