

Phono[®] Solar

TwinPlus Module

Perc/370-385W



PID Resistant



Better shading tolerance



More Reliable

Lower hot spot temperature



More Power

Low power loss in cell connection
Low temperature coefficient (Pmax): $-0.38\% / ^\circ\text{C}$
Low NOCT: $43 \pm 2^\circ\text{C}$

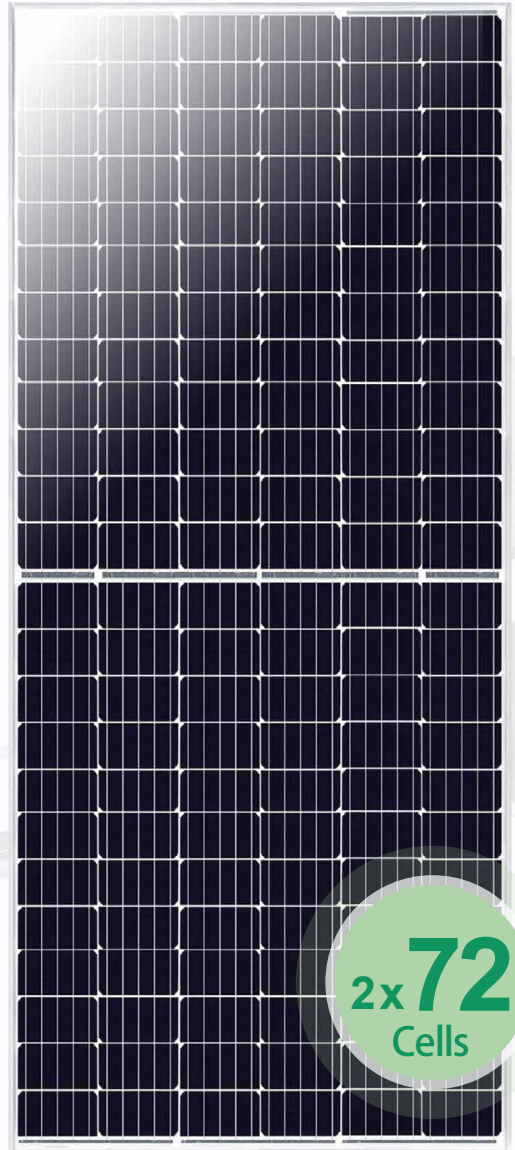

2x72
Cells

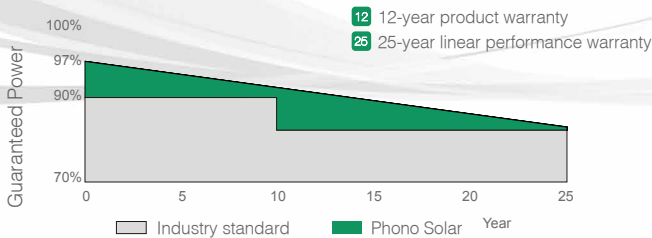

EN EN-20190514

ELECTRICAL TYPICAL VALUES

Model	PS370M-24/TH PS370MH-24/TH	PS375M-24/TH PS375MH-24/TH	PS380M-24/TH PS380MH-24/TH	PS385M-24/TH PS385MH-24/TH
Type	Monocrystalline 6 inch x 3 inch square			
Rated Power (Pmpp)	370W	375W	380W	385W
Tolerance	0~+5w			
Rated Current (Impp)	9.29	9.35	9.42	9.48
Rated Voltage (Vmpp)	39.83	40.11	40.35	40.62
Short Circuit Current (Isc)	9.71	9.79	9.87	9.95
Open Circuit Voltage (Voc)	47.44	47.69	47.94	48.19
Module Efficiency (%)	18.65	18.90	19.15	19.41
NOCT (Nominal Operation Cell Temperature)	43±2°C			
Voltage Temperature Coefficient	-0.30%/°C			
Current Temperature Coefficient	+0.05%/°C			
Power Temperature Coefficient	-0.38%/°C			

MECHANICAL CHARACTERISTICS

Dimension (L× W × H)	Length: 2000mm (78.75 inch) Width: 992mm (39.06 inch) Height: 40mm (1.57 inch)
Weight	22.6kg (49.8 lbs)
Front Glass	3.2mm toughened glass
Frame	Anodized aluminium alloy
Cable	4mm ² (IEC) , Length:350mm (vertical) 1250mm (horizontal) or Customized length
Junction Box	IP 68 rated

ABSOLUTE MAXIMUM RATING

Parameter	Values
Operating Temperature	From -40 to +85°C
Hail Diameter @ 80km/h	Up to 25mm
Surface Maximum Load Capacity	Up to 5400Pa
Maximum Series Fuse Rating	20A
Application Class and Safety Class	II
Fire Rating (IEC61730)	C
Module Fire Performance (UL 1703)	Type1
Maximum System Voltage	DC 1000V/1500V (IEC/ETL)

PACKING CONFIGURATION

Container	20' GP	40' HQ
Pieces/Container	230	616

- In compliance with our warranty terms and conditions.
- Measurement conditions under irradiance level of Standard Test Conditions(STC): 1000W/m
Air mass 1.5 Spectrum, cell temperature of 25°C.

ELECTRICAL CHARACTERISTICS

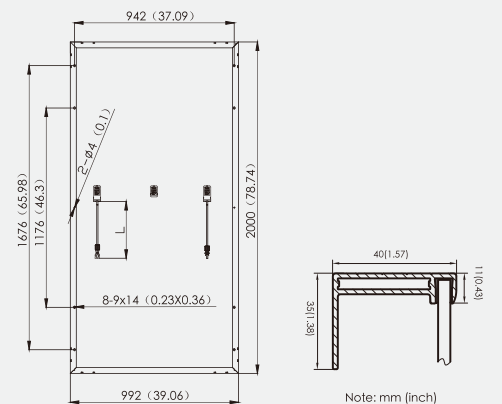
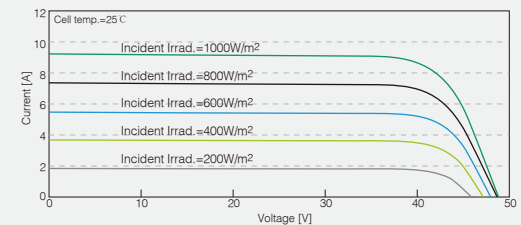
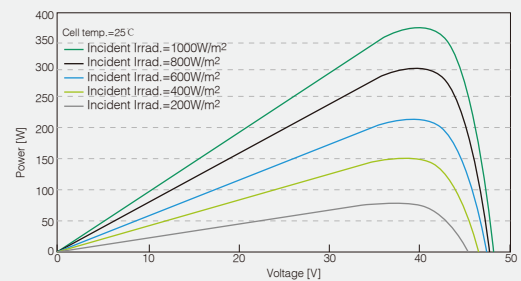

Phono[®] Solar

Note: This datasheet is not legally binding. Phono Solar Technology Co., Ltd. reserves the right to adjust specifications without notice. Further information please refer to our [Website:www.phonosolar.com](http://www.phonosolar.com), [E-mail:info@phonosolar.com](mailto:info@phonosolar.com)