

**CleverMade®**

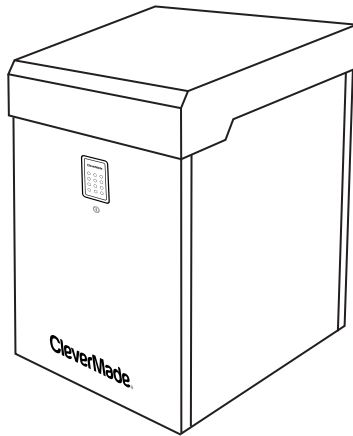

# PARCEL LOCKBOX S100 SERIES INSTRUCTION MANUAL

[CleverMade.com/LockBox](http://CleverMade.com/LockBox) | 1-800-761-9602 | [info@clevermade.com](mailto:info@clevermade.com)

## THANK YOU FOR PURCHASING

Thank you for purchasing a CleverMade® Parcel LockBox. Our LockBox is one of the very first delivery package lockers to come to market. In a world of accelerating e-commerce and residential deliveries, there has become a need to protect deliveries from theft and weather. CleverMade designed our LockBox with this in mind by using a sturdy gauge steel protected by a durable weather resistant powder coating.

Our LockBox features a lock that can be opened with a personal programmable digital code or a steel key. As an additional theft deterrent, the LockBox itself can be anchored to masonry or wood flooring using the supplied drill bit and anchor screws.

Since package lockers are still relatively new in the market, we suggest you follow our "belt and suspenders" approach to communicate with delivery carriers that you desire to have your packages placed and secured in your LockBox. This entails setting your delivery preferences and supplying your personal LockBox code to all of your delivery carries and if needed displaying provided instruction placards on your LockBox or front door.

We want you to have the best experience possible with your new LockBox. Parcel LockBoxes are new to the market so to get the best performance from your new LockBox it is important to follow all the steps outlined in this manual, especially the points listed below:

Important:

- Anchor the LockBox into the location selected using the 4 concrete/wood screws supplied
- Program your lock to your custom 4 digit code

- Use the carrier website or app to enter your lockbox location and share your code. Go to [clevermade.com/lockbox](https://clevermade.com/lockbox) for detailed instructions for each carrier or call us at 760-814-3577 or 800-761-9602 for CleverMade customer support
- When entering your address for deliveries, always provide your code in the open second address line:  
Ex: John Smith  
Use LockBox Code 1234#  
555 Maple Lane  
Orchard, NC 27006
- Train and inform your carrier drivers. Use the LockBox Magnet provided to catch drivers attention. Also use the front door hanger to direct the driver to the LockBox.
- When possible talk to your driver, share your code and let them know that all packages are to be put into your LockBox. Every driver carries a smart phone/device capable of entering specific delivery instructions that automatically go into your profile.

Please note all safes and lockers are meant to deter theft. Given enough time and/or the right tools all safes and lockers can be compromised. Hence our 10 year warranty is limited to manufacturing defects and parts up to the cost of the LockBox.

Should you experience any problem or concern regarding your LockBox we are available to help Monday through Friday from 9 am - 5 pm PST. Just call us at 760-814-3577 or 800-761-9602 or e-mail us at [info@clevermade.com](mailto:info@clevermade.com). Additionally, [www.CleverMade.com/LockBox](https://www.CleverMade.com/LockBox) is a great tool for assembly videos and guidance on supplying your personal code to delivery carries.

## TABLE OF CONTENTS

Warnings & Cautions.....	Page 2
LockBox Assembly.....	Page 4
Keypad Instructions.....	Page 11
Anchoring Instructions.....	Page 13
Warranty.....	Page 15

## WARNINGS & CAUTIONS

### WARNINGS

- Before shutting the lid be sure that all hands, fingers and objects are clear to avoid serious injury or damage to product.
- Under NO circumstance should anyone ever climb into the LockBox.  
**In the event that someone is shut in the LockBox there is a glow-in-the-dark EMERGENCY LATCH on the inside of the LockBox at the top behind the key pad.**

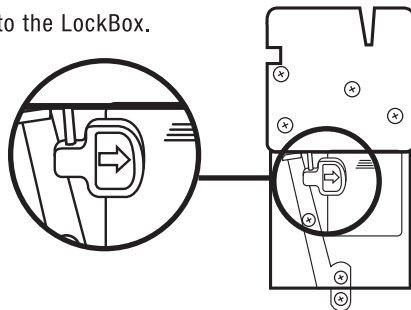

### CAUTIONS

- Do not sit, stand or place objects on the LockBox. Doing this could compromise the structure of the LockBox.
- Hitting or impacting the digital lock or LockBox could compromise the structure and performance.
- The LockBox is meant to deter theft. Given enough time and/or the right tools it can be compromised. Please note our warranty is limited to manufacturing defects and parts up to the cost of the LockBox.
- During assembly, rest the metal parts on a soft surface to avoid scratching LockBox or damaging the floor.
- Two or more people should be used to assemble, move or install the LockBox.
- Remove all parts from the packaging and lay them out in an open space.

**WARNING:** Under NO circumstance should anyone ever climb into the LockBox.



## BEFORE YOU BEGIN

- Make sure you have all the parts before beginning assembly. For ease of assembly, we recommend laying the parts out in the same order as the next page.
- Is reading instructions not your thing? Watch the assembly video at [www.CleverMade.com/LockBox](http://www.CleverMade.com/LockBox)

# PARTS FOR ASSEMBLY

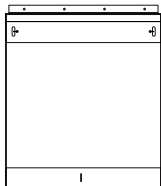

A-TOP LID

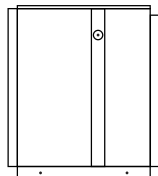

B-LEFT SIDE PANEL

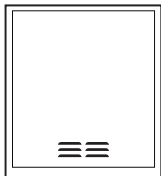

C-BACK PANEL

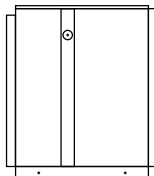

D-RIGHT SIDE PANEL

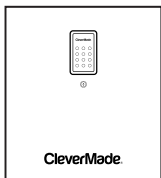

E-FRONT PANEL

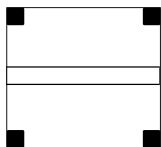

F-BOTTOM PANEL

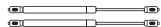

G-LID STRUTS (2)



SCREWS (27)  
(includes 1 extra screw)



AAA BATTERIES (4)

## TOOLS NEEDED:



PHILLIPS HEAD SCREWDRIVER  
(NOT INCLUDED)

OR:



POWER DRILL  
(NOT INCLUDED)



2 PEOPLE RECOMMENDED  
FOR THIS STEP

## ANCHOR TOOLS:

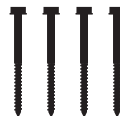

4 ANCHORING SCREWS



MASONRY  
BIT



PHILLIPS  
HEAD BIT



## INSTALL THE BATTERIES

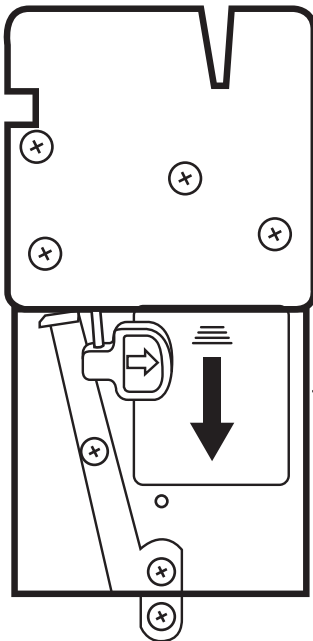

Keypad Back  
(Access from inside the LockBox)

-Slide off the back of the battery case and install the provided AAA batteries.

NOTE: For use in temperatures below 0° Fahrenheit we suggest using Energizer Lithium batteries that are designed to be used in temperature as low as -40° Fahrenheit.

LOW BATTERY WARNING: The lock will emit a repetitive beep every 3-4 seconds when the batteries are running low. When this occurs new batteries should be installed.

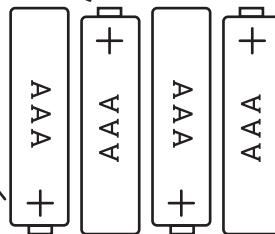

NOTE: Do not mix old and new batteries. Do not mix alkaline, standard (carbon-zinc), or rechargeable batteries.

STEP 1-ATTACH WALL PANELS



**1a-** Attach Left Side Panel (B) to Back Panel (C) and secure with screws.

**1b-** Attach Right Side Panel (D) and secure with screws.

**1c-** Attach Front Panel (E) and secure with screws.

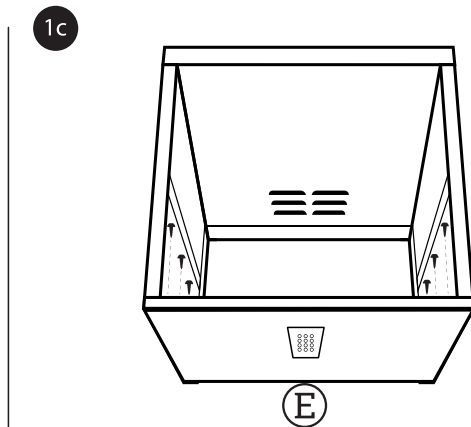
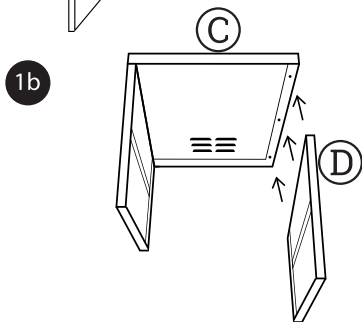
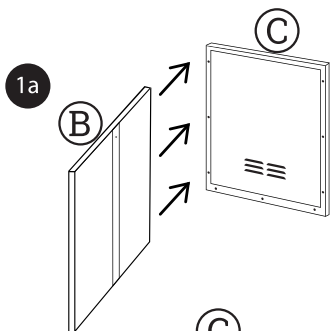

## STEP 2-ATTACH BOTTOM PANEL

10x



**2a-** Flip LockBox upside down.

**2b-** Place bottom Panel (F) onto box and secure with screws.

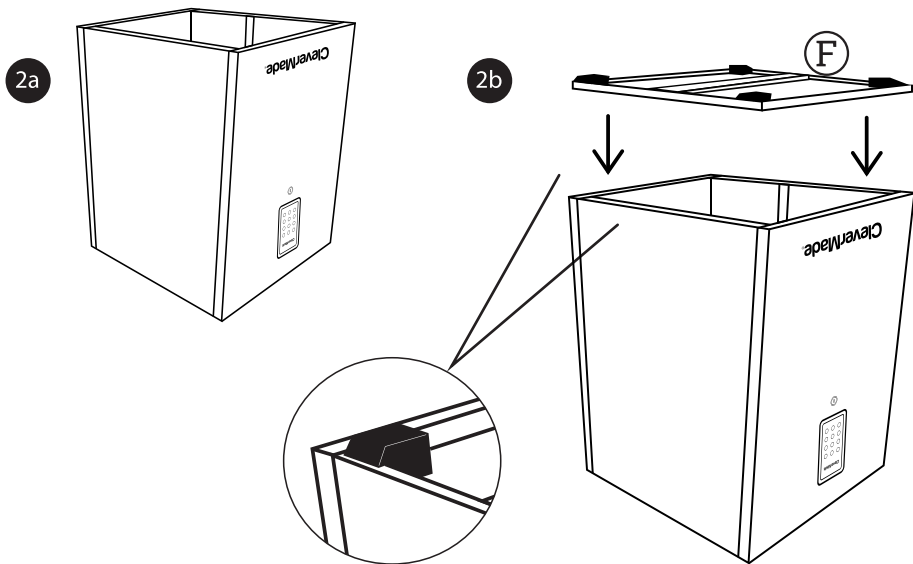



## STEP 3-ATTACH LID

3a- Flip LockBox upright.

3b- Attach Lid (A) to Back Panel (C) and secure with screws.

**NOTE: Lid hinge should not go past 90°. Your partner should hold the lid in place through step 4.**

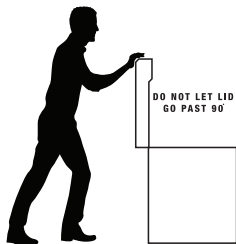
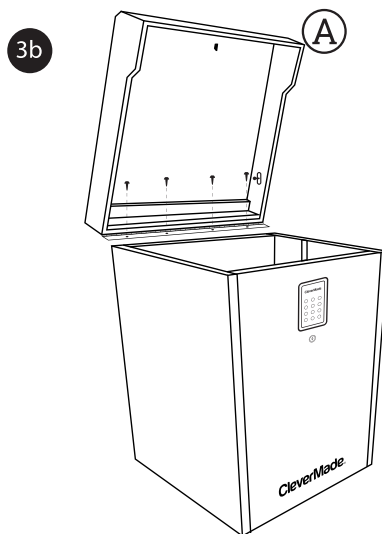
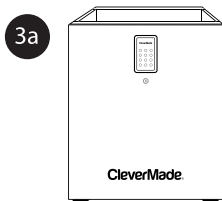
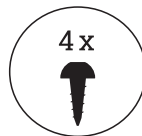

## STEP 4-ATTACH LID STRUTS

4- Attach the Lid Struts (G) to the Side Panels and Back Panel. The Lid Struts will click into the connectors.

**NOTE:** Keep Lid open for ease of setting your personal code.

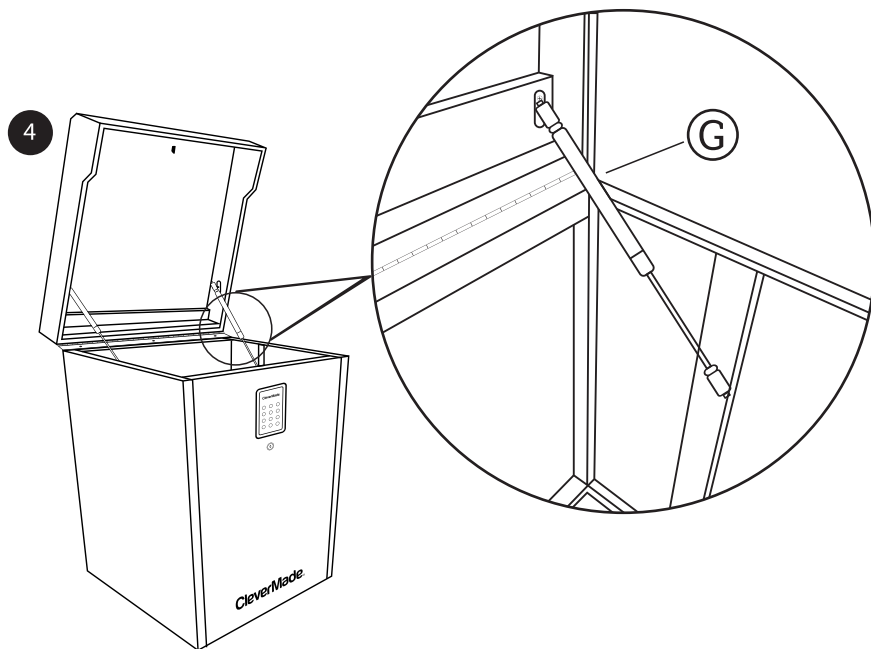

## SET UP YOUR PERSONAL CODE

**NOTE:** If the light on the LockBox screen turns off while setting up your code you will need to start over.



1. Press the “#” to activate the screen  
(NOTE: lock won’t beep or light up)
2. Press the “#” button two additional times
3. Enter the preset factory four digit passcode (0000)
4. Press the “#” button twice again
5. Now enter your desired four digit passcode
6. Press the “#” button twice-you should hear two beeps
7. Once the lock beeps twice, your personal code is set

To open the box, simply enter your four digit code and then press the “#” button. The lid will pop open.

## CHANGING YOUR PERSONAL CODE

### Option 1: With the lid closed

1. Press the “#” to activate the screen  
(NOTE: lock won't beep or light up)
2. Press the “#” button two additional times
3. Enter your current four digit passcode
4. Press the “#” button twice again
5. Now enter your desired four digit passcode
6. Press the “#” button twice-you should hear two beeps
7. Once the lock beeps twice, your personal code is set

### Option 2: With the Key

1. Use the key to manually open the box
2. Hold reset button inside the box for five seconds
3. Once the lock beeps you are ready for new passcode
4. Press the “#” button twice
5. Enter desired four digit passcode
6. Press the “#” button twice-you should hear two beeps
7. Once the lock beeps, your new personal code is set

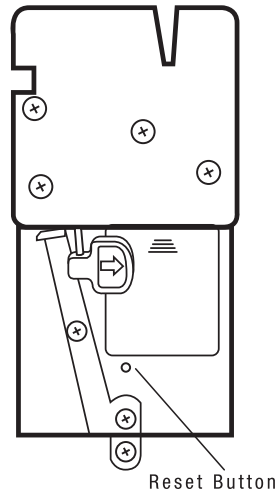

---

Visit [www.CleverMade.com/LockBox](http://www.CleverMade.com/LockBox)  
for guidance on creating or updating a delivery profile  
to provide your delivery carriers with your LockBox code.

## STEP 1-DRILLING ANCHORING HOLES

### TOOLS NEEDED

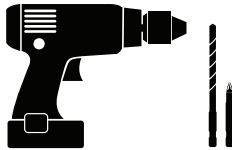

POWER DRILL (NOT INCLUDED) , MASONRY DRILL BIT,  
AND PHILLIPS DRILL BIT (BITS INCLUDED)

### ANCHORING PARTS

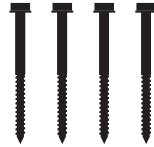

4 ANCHORING SCREWS

Before you begin: Place the LockBox in desired location. **The back of the LockBox needs to be at least 2 inches away from any wall or other surface before you begin to anchor.** This will allow the lid to open properly without interference.

- Using your power drill with the masonry bit (included), insert the bit into the open hole in one of the four bottom corners and drill into the ground. (Please note: this drill bit will work on wood or concrete).
- Repeat drilling in all four corners.

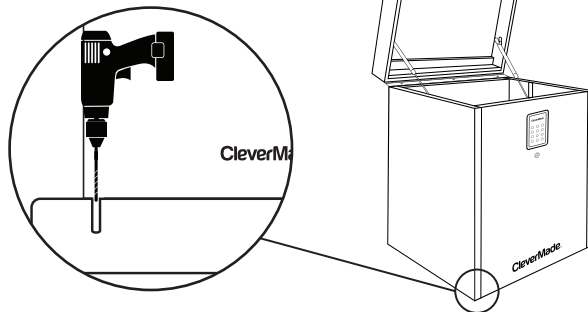



## STEP 2-ANCHORING LOCKBOX TO GROUND

Remove the masonry drill bit from the drill and insert the Phillips driver bit.

- Using the power drill, insert one of the screws provided into the open hole in one of the four bottom corners and secure it to the ground.
- Repeat fastening screws in all four corners.

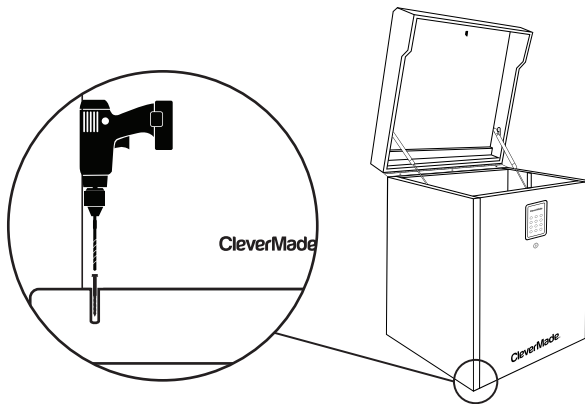

CleverMade takes pride in the quality and craftsmanship of our products. This is why we offer a free Limited 10 Year Warranty on our LockBox product with proof of purchase by the original owner. The 10 Year Warranty covers manufacturing defects and failure of moving parts under normal use. We will repair or replace, at our option, any product or component that is defective in material or workmanship for 10 years. If your product or part is determined to be defective, contact our Customer Service Department at 760-814-3577 or 800-761-9602 (9-5 PST) and we will assist you in settling the defective issue. Any defective parts will be replaced free of charge. The 10 Year Warranty excludes deliberate or accidental damage and does not extend to misuse, finishes, rust, or improper installation. However, we evaluate each Warranty claim on a case by case basis, so please contact us should you have any questions or concerns about your CleverMade LockBox product.

Protect your warranty by registering your LockBox at:  
[CleverMade.com/LockBox/register](https://CleverMade.com/LockBox/register)



## CALL US FIRST! DO NOT RETURN LOCKBOX TO STORE.

For immediate help with assembly or product information call our toll free number 1-800-761-9602 or email [info@clevermade.com](mailto:info@clevermade.com)

Our staff is ready to provide assistance M-F 9-5 PST.

## LOST YOUR KEYS?

For key replacement, please call 1-800-761-9602 or email us at [info@clevermade.com](mailto:info@clevermade.com)  
Please note that we will require additional information upon contacting us, to ensure security through the replacement process.

The logo for CleverMade is presented within a dark, rounded rectangular frame with a thin white border. The text "CleverMade" is written in a bold, white, sans-serif font, with a registered trademark symbol (®) positioned to the upper right of the word "Made".

**CleverMade®**

2556 Gateway Road Carlsbad, California 92009

760.814.3577 or 800.761.9602

[info@clevermade.com](mailto:info@clevermade.com)

[www.CleverMade.com](http://www.CleverMade.com)