



AURORA ALUMINIUM HINGE & PIVOT DOOR QUICK ORDER FORM

COMPANY NAME _____	SUBURB/POSTCODE _____	SITE CONTACT PHONE _____
YOUR NAME _____	ORDER DATE _____	DELIVERY TIME _____
PROJECT NAME _____	DUE DATE _____	SPECIAL INSTRUCTIONS _____
DELIVERY ADDRESS _____	CUSTOMER ORDER # _____	_____
_____	SITE CONTACT NAME _____	_____

DOOR TYPE <small>(Hinge or pivot)</small>	DOOR FINISH <small>(Powdercoat or natural/special anodised)</small>	COLOUR <small>(If finish is powdercoat or special anodised)</small>	GLAZING <small>(6.38mm or 10.38mm)</small>	STILE SIZE <small>(refer to p.2)</small>	TOP RAIL SIZE <small>(refer to p.2)</small>	BOTTOM RAIL SIZE <small>(refer to p.2)</small>	MID RAIL SIZE <small>(If appl. refer to p.2)</small>	MID RAIL POSITION (mm) <small>(Top of rail from bottom of door)</small>

DOOR REF #	SIZE				LOCKS & HANDLES						HARDWARE						ADDITIONAL MACHINING	
	FINISHED HEIGHT <small>(mm)</small>	FINISHED WIDTH <small>(mm)</small>	INACTIVE DOOR WIDTH <small>(mm)</small>	HANDING ACTIVE/INACTIVE <small>(refer to p. 2)</small>	LOCK/ HANDLE TYPE <small>(refer to p. 3)</small>	SUPPLY & FIT	HANDLE HEIGHT <small>(mm to centre of lever)</small>	MACHINE ONLY				BOTTOM SEAL <small>(refer to p. 3)</small>	MACHINE ONLY	SUPPLY & FIT	FLUSH BOLT TOP	FLUSH BOLT BASE		DOOR CLOSER (PIVOT) MACHINE ONLY <small>(refer to p. 3)</small>
								FACEPLATE	HANDLE HOLES	CYL. HOLE (Outside)	TURN SNIB							

SPECIAL INSTRUCTIONS
 All hardware must be ordered separately. If provided from a different supplier, please include manufacturer code and specifications for accurate machining.

Send completed form to:
VIC orders@criterionindustries.com.au
NSW sales.nsw@criterionindustries.com.au
WA sales.wa@criterionindustries.com.au





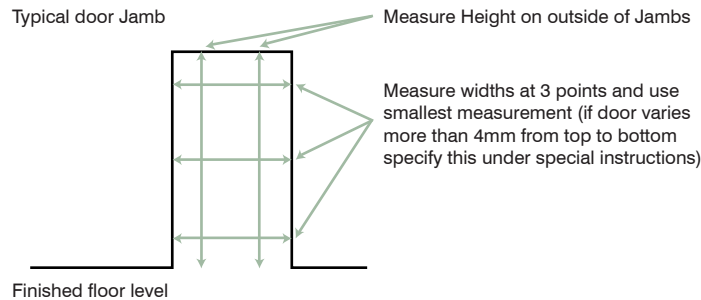

STANDARD MEASURING AND MANUFACTURING DETAILS

DOOR WIDTH	Daylight Width - 9mm
DOUBLE DOOR WIDTH	Daylight Width - 13mm (4mm each side for hinges and 5mm gap between meeting stiles)
DOOR HEIGHT	Daylight Height - 15mm off Finished Floor Level (3mm from the top and 12mm from base) - X (allowances for Floor Finishes)
STANDARD HANDLE HEIGHT	1000mm to centre of lever from base of door
STANDARD MACHINING DETAILS	Cylinder Hole is always machined to outside of door unless otherwise specified

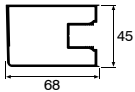
METHOD OF MEASURING DOOR OPENINGS

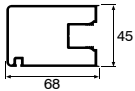
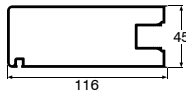
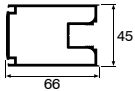

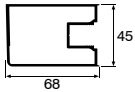

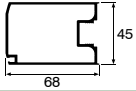
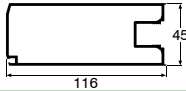
STILE TYPES



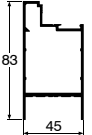
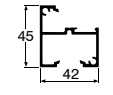
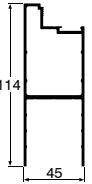
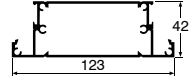

Plain 66mm		Wide Plain 114mm	
Wiper 66mm		Wide Wiper 114mm	
Pivot 66mm		Wide Pivot 114mm	
Hinge 66mm		Wide Hinge 114mm	
Lock 66mm		Wide Lock 114mm	

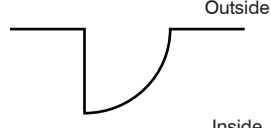
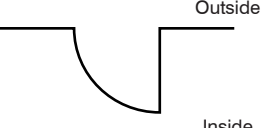
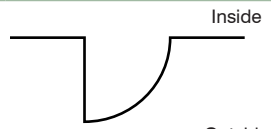

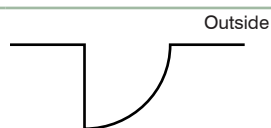
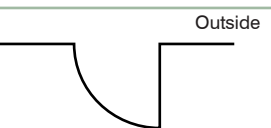
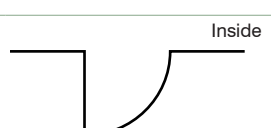
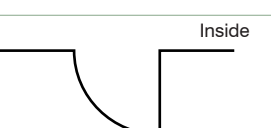



RAIL TYPES

Top/Bottom Rail 83mm		Mid Rail 45mm	
Top/Bottom Rail 114mm		Mid Rail 123mm	

HANDING LEGEND

	LEFT HANDED DOORS	RIGHT HANDED DOORS
Active Leaf	HL01 	HLR01 
	HL02 	HLR02 
Inactive Leaf	HL03 	HLR03 
	HL04 	HLR04 

LOCK/HANDLE DESCRIPTION	TUBULAR LATCH	A0901 LOCKWOOD ENTRANCE SET	STANDARD BACKSET MORTICE LOCK	NARROW BACKSET MORTICE LOCK	ROLLER BOLT
					
Kit code	.Tub	.EntA90	.StdMor	.N/BMor	.Rol
Kit code description	Prep for Tubular Latch	Prep for A0901 Lockwood Entrance Set	Prep for Standard Hinged Mortice	Prep for Narrow Backset Mortice	Prep for Roller Bolt
Kit components	Machine for Tubular Latch Plate	Machine for A0901 Entrance Set	Machine for Lockwood Faceplate (114mm)	Machine for Lockwood Faceplate (66mm)	Machine for Roller Bolt
	Machine for Lever Holes		Machine Standard Mortice Lock Cylinder Hole	Machine Narrow B/Set Mortice Lock Cylinder Hole	
			Machine Standard Mortice Lock Turnsrib Hole	Machine Narrow B/Set Mortice Lock Turnsrib Hole	
			Machine for Lever Holes	Machine for Lever Holes	

SEAL DESCRIPTION	STANDARD BOTTOM SEAL	HEAVY DUTY BOTTOM SEAL	DOOR CLOSER DESCRIPTION	TRANSOM CLOSER	FLOOR SPRING	FLUSH BOLT DESCRIPTION	ADDITIONAL MACHINING	ELECTRONIC TRANSFER SPRING			
											
Kit code	.StdSea	.HeaSea	Kit code	.TraClo	.FloSpr	Kit code	.FluBol	Kit code	.TraSpr		
Kit code description	Prep for IS8010/RP8 Seal	Prep for IS8100/RP70 Seal	Kit code description	Prep for Overhead Transom Closer	Prep for Floor Spring	Kit code description	Prep for Flush Bolt	Kit code description	Prep for Transfer Spring		
Kit components	Machine for IS8010/RP8 seal to Base	Machine for IS8100/RP70 seal to base	Kit components	Infill top of door with timber to create a 17mm rebate, to suit a 65mm pivot point on the hinge side	Infill top of door with timber to create an 8mm Rebate	Kit components	Machine for 600mm Flush Bolt to Base	Kit components	Machine Hinge Stile for Transfer Spring		
				Infill base of door to create a 19mm rebate, to suit a 65mm pivot point on the hinge side	Infill base of door with timber to create a 20mm rebate		Machine for 300mm Flush Bolt to Base				
							Machine for 600mm Flush Bolt to Top				
							Machine for 300mm Flush Bolt to Top				