

# iBIRD® PRO

**iBird® Pro – the optional setting process assistant from GESIPA® provides assistance when evaluating riveting processes**

**No. 156 7800**

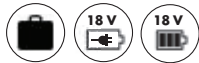

**No. 156 7801**

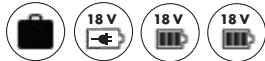

## TECHNICAL DATA

Connection: WiFi 2.4/5.0 GHz and Bluetooth  
Setting force: 15,000 N  
Weight: 2.2 kg with battery  
Drive: 18 V brushless DC motor (BLDC)  
Stroke: 25 mm

## SCOPE OF DELIVERY

Nosepieces: 17/32, 17/36, 17/40 and 17/45  
Additional jaw pusher for smaller blind-rivet dimensions (Required nosepieces page 136)

## WORKING RANGE

Blind rivets from Ø 2.4 mm alu/steel, up to Ø 6.4 mm all materials, up to Ø 8 mm aluminium, except G-Bulb Ø 6.4 mm and stainless steel PolyGrip® Ø 6.4 mm, BULB-TITE® blind rivets up to Ø 7.7 mm all materials. MEGA GRIP® blind rivets up to Ø 6.4 mm all materials. (max. mandrel Ø 4.3 mm)

## INDUSTRY 4.0 WITH THE IBIRD® PRO

Known as Industry 4.0, M2M or the Internet of Things, these concepts refer to intelligent and digitally networked systems in the production industry. The aim is to ensure that production is as self-organised as possible. GESIPA® has developed the iBird® Pro with this in mind. The iBird® Pro is a networked battery-powered setting tool that can be connected to smartphones, tablets or a customer's IT infrastructure using WiFi or Bluetooth via a free GESIPA® app. This networking provides a number of additional benefits such as the monitoring of riveting processes, processing safety, status and service indicators, as well as quick and simple access to operating, maintenance and repair instructions – ultimately resulting in optimisation of the value chain.

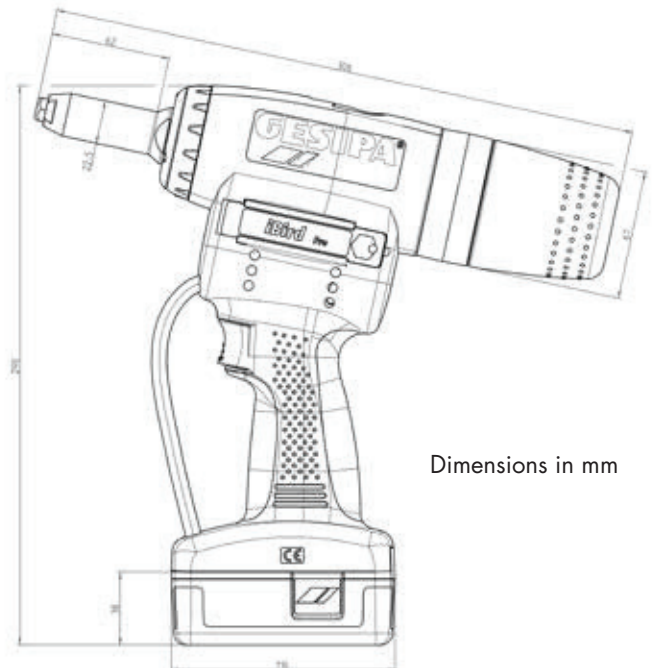

Make sure the correct jaw pusher is used as specified in the operating instructions!

**NOSEPIECE ASSIGNMENT** Power per battery charge

D	Material	approx.pc / battery charge	Nosepiece	No.
4.8 and 5.0	Steel, Alu	<b>1,000</b>	17/32	<b>143 4975</b>
4.8 and 5.0	Stainless steel	<b>700</b>	17/36	<b>143 4977</b>
6.0	Alu	<b>650</b>	17/36	<b>143 4977</b>
6.0	Steel	<b>500</b>	17/40	<b>143 4999</b>
6.4	Alu, PG-Alu	<b>550</b>	17/45	<b>143 4860</b>
6.4	Steel	<b>450</b>	17/45	<b>143 4860</b>
8	Alu	<b>500</b>	17/45	<b>143 4860</b>

The name of the nosepiece (e.g. 17/32) can be found directly on the nosepiece.



**BULB-TITE® BLIND RIVETS\***

4.0	Alu	<b>1,200</b>	17/26 BT*	<b>143 4985</b>
5.2	Alu	<b>1,000</b>	17/32 BT*	<b>143 4986</b>
6.3	Alu	<b>800</b>	17/42 BT*	<b>143 4988</b>
6.3	Steel	<b>700</b>	17/42 BT*	<b>143 4988</b>
6.3	Monel	<b>650</b>	17/42 BT*	<b>143 4988</b>
7.7	Alu	<b>700</b>	17/48 BT*	<b>143 4989</b>

**MEGA GRIP® BLIND RIVETS\***

4.8	Alu	<b>800</b>	17/31 MG*	<b>143 4993</b>
4.8	Steel	<b>750</b>	17/31 MG*	<b>143 4993</b>
4.8	Stainless steel	<b>750</b>	17/31 MG*	<b>143 4993</b>
6.4	Alu	<b>700</b>	17/41 MG*	<b>143 4865</b>
6.4	Steel	<b>300</b>	17/41 MG*	<b>143 4865</b>
6.4	Stainless steel	<b>250</b>	17/41 MG*	<b>143 4865</b>

\* available as special accessory. Special design nosepieces are available on request. The nosepiece allocation data applies to DIN and GESIPA® blind rivets.

**88** Spare parts and special accessories iBird® Pro **page 88.**

**136** Extended nosepieces, special lengths and special nosepieces on **page 136.**

## iBird® Pro – Advantages at a glance!

### ADVANTAGES

- For smartphone, tablet, PC
- Simple connection to the tool with GESIPA® app via QR
- Data availability at any time
- A signal ring (andon ring) for visualising riveting processes
- Optional connection to three devices at the same time
- Premium software: optional (availability of) setting process

### TECHNICAL FACTS

- WiFi 2.4/5.0 GHz and Bluetooth (LE) wireless connection
- Tilt sensor can be connected via the app; during use, the tool is only enabled for the next riveting process once the tilting motion for ejecting the mandrel body has been performed
- Andon ring: Signal ring for visualising the riveting process, the colours can be set individually via the app

### PREMIUM SOFTWARE

Optional setting process assistant\*

- Setting process evaluation with fault detection, notification in app and via Andon ring (signal ring lights up based on the setting process evaluation and colour setting)
- Teaching mode for teaching in rivet configurations
- Creation of job lists to process various rivet configurations

**No. 157 0451**

\*Once paid premium software has been activated

### THE ANDON RING

The iBird® Pro incorporates a signal ring for visualising riveting processes. The colours can be set individually via the app.



## Die GESIPA® app – simple connection and all information you need at a glance!

### THE GESIPA® APP

Using a QR code, the iBird® Pro can be connected to the GESIPA® app with ease. The app is available for smartphones, tablets and PCs (Android and iOS).

The iBird® Pro can be connected to three devices at the same time.

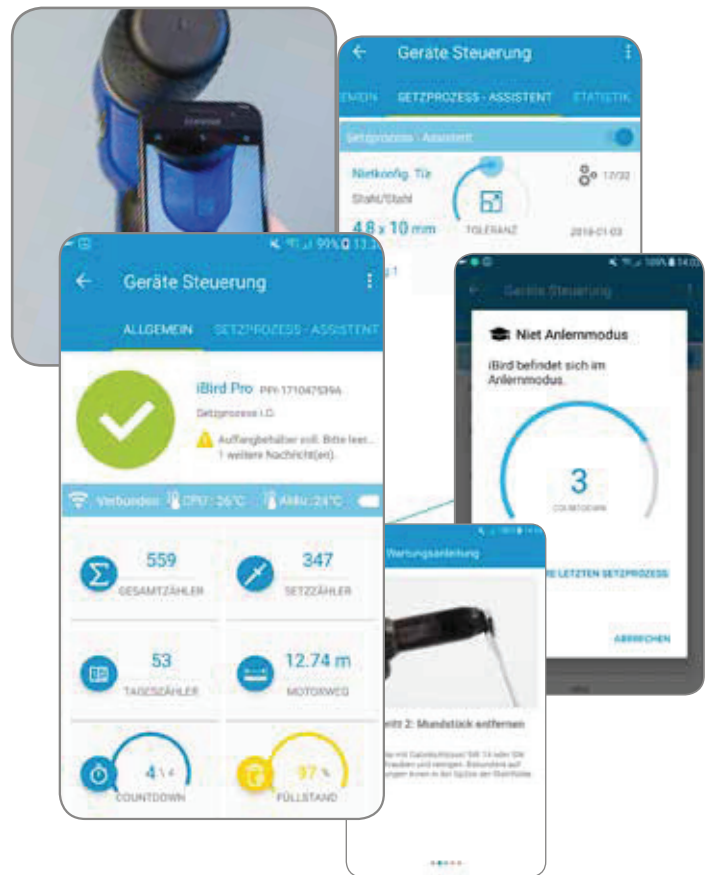

2

Simple connection of the iBird® Pro with the GESIPA® app via QR code

For smartphone, tablet, PC (Android and iOS)

Premium software: setting process assistant

Connection with three smartphones, tablets or PCs at the same time (e.g. operator, foreman, process control centre)

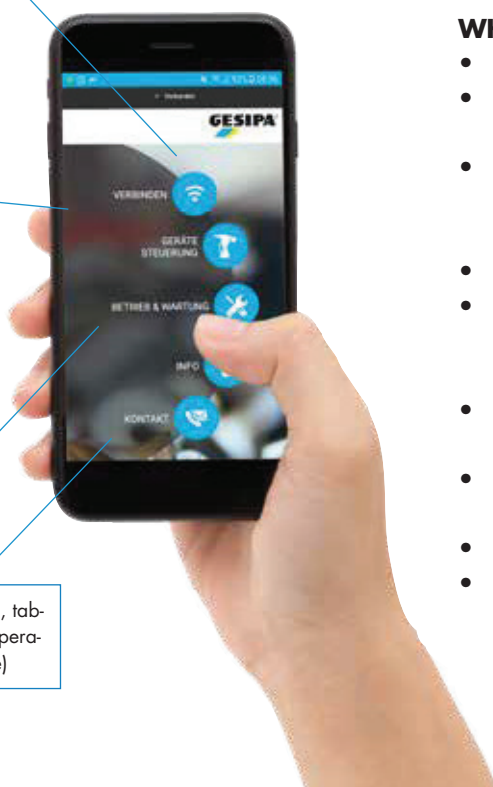

### WHAT THE IBIRD® PRO APP OFFERS:

- Various counters:
- Total, day, setting counter, countdown, OK\*, NOK\*.
- Fill level indicator, service indicator (spent mandrel container, cleaning or oiling jaws, full service)
- Optional setting process assistant\*
- Monitoring of battery charge level, battery temperature and temperature of the tool control
- Maintenance instructions, maintenance history
- Error message, error history, acknowledgement history
- Tips and tricks
- Operating instructions

\*Once paid premium software has been activated

# SPARE PARTS / SPECIAL ACCESSORIES for Bird Pro series

## 18.0 V/2.1 AH (LI-ION) SLIDE-ON BATTERY PACK

Weight: 0.4 kg / available as special accessory



**No. 145 7641**

## CHARGER FOR 18.0 V LI-ION BATTERY

### Technical data

Input voltage: 100 - 240 V / 50 - 60 Hz

Output voltage: 21 V DC

Charging time: 45 to 90 minutes

Weight: 0.6 kg



Note: Equipped with Euro plug as standard (other versions on request)

**No. 145 7642**

## RETAINING NOSEPIECE

Special accessory (also for SN2)

- Inserted rivet stays in any position
- Set rivets with only one hand
- Safer working



17/18R **No. 165 5422**  
17/20R **No. 165 5424**  
17/22R **No. 165 5426**  
17/24R **No. 165 5427**  
17/27R **No. 165 5428**  
17/29R **No. 165 5429**  
17/32R **No. 165 5430**  
17/36R **No. 165 5431**  
17/40R\* **No. 165 5433**  
17/45R\* **No. 165 5434**

\*Except AccuBird® Pro

## JAWS (3-PART)



**No. 143 5568**

## TRANSPARENT SPENT MANDREL CONTAINER

The classic spent mandrel container allows you to keep an eye on the amount of spent mandrels.



**No. 145 0837**

## EXTENSION FOR SPENT MANDREL



Extended by 30 mm  
**No. 145 0838**  
Extended by 60 mm  
**No. 145 0839**

## ANGLE HEAD 90°

For use in very narrow and confined spaces



**No. 146 4882**

# SPARE PARTS / SPECIAL ACCESSORIES for Bird Pro series

## EXTENSION UNITS

### ONE-PIECE

replace the steel head sleeve, they are slim and are therefore particularly suitable for tight spaces that are difficult to access



TOOL	+35 mm	+85 mm	+135 mm
AccuBird® Pro	<b>145 0860</b>	<b>145 0861</b>	<b>145 0862</b>
PowerBird® Pro	<b>145 7650</b>	<b>145 7651</b>	<b>145 0823</b>
PowerBird® Pro Gold Edition	<b>145 7650</b>	<b>145 7651</b>	<b>145 0823</b>

TOOL	+50 mm	+100 mm	+150 mm
PowerBird® Pro Gold Edition with spring-loaded trigger system	<b>145 0821</b>	<b>145 0822</b>	-

### EXAMPLE one-piece

#### Bird Pro Geräte

Example: + SL 35 mm

Steel head sleeve length =  
62 mm (X) + SL 35 = 97 mm

#### PowerBird Pro GE with spring-loaded trigger system

Example: + SL 50 mm

Steel head sleeve length =  
57,5 mm (X) + SL 50 mm = 107,5 mm

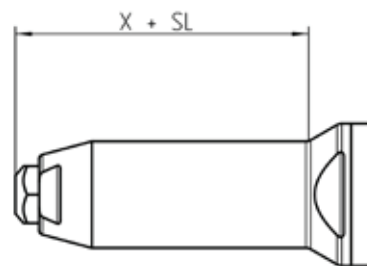

The variable X can be found in the dimension drawings of the devices.

**Dimension X** = Standard steel head sleeve length (with standard nosepiece)

### MULTI-PIECE

are suitable for riveting in low-lying places. They are screwed on between the tool and the existing steel head sleeve

Variable extension of the steel head sleeve is possible in steps of 100 mm

TOOL	+100 mm
AccuBird® Pro	<b>145 0859</b>
PowerBird® Pro	<b>145 0820</b>
PowerBird® Pro Gold Edition	<b>145 0820</b>



### BEISPIEL multi-piece

#### Bird Pro Geräte

Example: + SL 100 mm

Steel head sleeve length =  
62 mm (X) + SL 100 mm = 162 mm