

FIREBIRD® PRO GOLD EDITION

**FireBird® Pro Gold Edition –
The new battery powered
blind rivet nut setting tool –
for blind rivet nuts up to
M12 steel!**

No. 145 0841



No. 152 4713

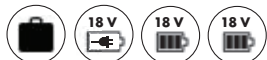

Setting force guide – Example: Steel M5

The values given are only guide values. The values should always be set slightly lower when setting for the first time!

TECHNICAL DATA

Weight: 2.4 kg with battery
Traction power: 20,000 N
Drive: brushless DC motor
Stroke: 10.0 mm



Power per battery charge,
threaded mandrels and
nosepieces **page 227.**

WORKING RANGE

Blind rivet nuts up to M12 alu and steel
and M10 stainless steel.

SCOPE OF DELIVERY

Threaded mandrel and nosepiece M6
(in working position),
Threaded mandrel and nosepiece M8
and M10 (in magazine)
1x Hexagonal wrench
1x Double open ended wrench SW 24/27
Card Quick adjustment
Card Setting force pre-adjustment
Operating manual



Spare parts, special accessories
for FireBird® Pro/FireBird® Pro
Gold Edition **page 230.**

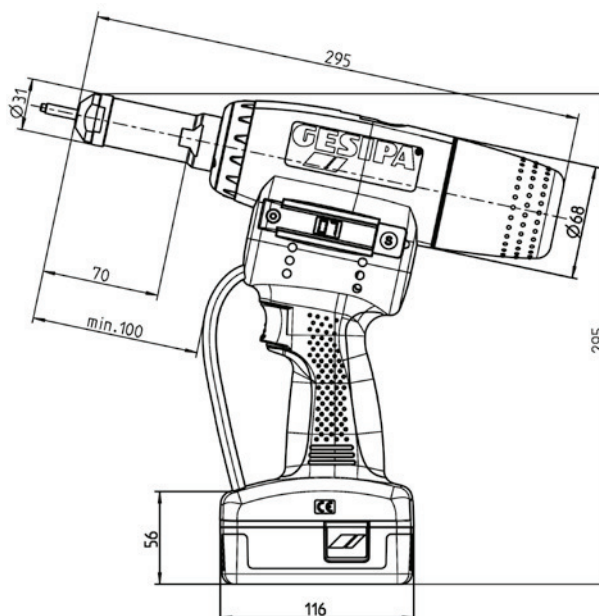

Dimensions in mm

WORKING RANGE FIREBIRD® PRO GE AND FIREBIRD® PRO GE S:

Sets blind rivet nuts up to M12 alu and steel and M10 stainless steel.

POWER PER BATTERY CHARGE/THREADED MANDRELS AND NOSEPIECES FOR FIREBIRD® PRO TOOLS

Inner thread	Material	approx. pc per charging process FireBird® Pro	Threaded mandrel	Nosepiece	approx. pc per charging process FireBird® Pro GE / FireBird® Pro S GE	Threaded mandrel	Nosepiece
			No.	No.		No.	No.
M3	Alu	1,200	143 6211*	143 6218*	1,200	143 6211*	143 6218*
M3	Steel/Stainless steel	1,100			1,100		
M4	Alu	1,100	143 6212	143 6219	1,100	143 6212	143 6219
M4	Steel/Stainless steel	1,000			1,000		
M5	Alu	950	143 6213	143 6220	950	143 6213	143 6220
M5	Steel/Stainless steel	900			900		
M6	Alu	900	143 6214	143 6221	900	143 6214	143 6221
M6	Steel/Stainless steel	800			800		
M8	Alu	850	143 6215*	143 6222*	850	143 6215	143 6222
M8	Steel/Stainless steel	550			550		
M10	Alu	750	143 6216*	143 6223*	750	143 6216	143 6223
M 10	Steel/Stainless steel	500			500		
M12	Alu	-	-	-	500	143 6217*	143 6224*
M12	Steel	-			300		

*Available as special accessory



230

Spare parts, special accessories for FireBird® Pro S Gold Edition **page 230.**



248

All threaded mandrels and nose-piece **page 248.**

Example and application:

Extended nosepiece and threaded mandrel for difficult-to-access and/or deep-seated applications

