

FIREBIRD® PRO

FireBird® Pro – The new battery powered blind rivet nut setting tool - for blind rivet nuts up to M8 steel!

No. 152 4639

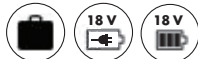

No. 152 4712

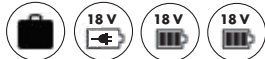

ADVANTAGES OF SETTING FORCE ADJUSTMENT

- Controlling the tool through setting force adjustment protects material and thread and anchors blind rivet nuts securely in the material
- Quick and easy setting force adjustment via the display or the colour-coded setting ring
- Does not need to be adjusted in case of changing material thicknesses or different lengths of blind rivet nuts

TECHNICAL DATA

Weight: 2.4 kg with battery
Traction power: 15,000 N
Drive: brushless DC motor
Stroke: 10.0 mm

WORKING RANGE

Blind rivet nuts up to M10 Aluminium, M8 steel and M6 stainless steel

SCOPE OF DELIVERY

Threaded mandrel and nosepiece M6 (in working position),
Threaded mandrel and nosepiece M4 and M5 (in magazine)
1x Hexagonal wrench
1x Double open ended wrench SW 24/27
Card Quick adjustment
Card Setting force pre-adjustment
Operating manual



Child's play!

- 1 Read off number
 - 2 Enter number
 - 3 Set blind rivet nut
- ➔ Done!

ADVANTAGES

- Foolproof operation
- Virtually no wear by brushless motor
- Modern Li-Ion battery technology
- Controlled solely by the setting force adjustment
- Intelligent error message
- Almost double the pulling displacement from 5.5 to 10 mm
- Fully automatic screw-off procedure

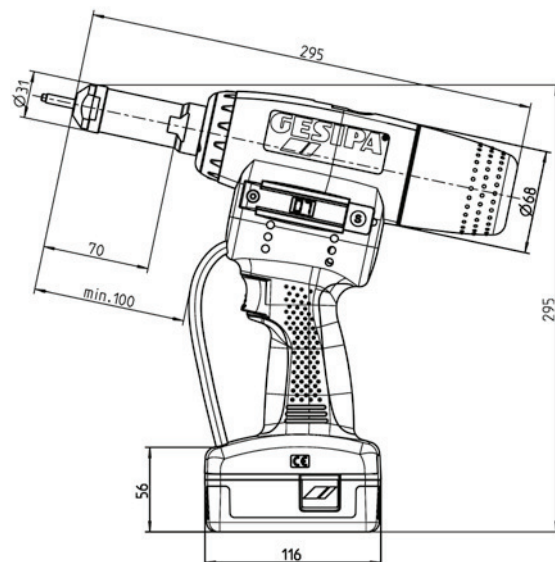

Dimensions in mm

FIREBIRD® PRO GOLD EDITION

**FireBird® Pro Gold Edition –
The new battery powered
blind rivet nut setting tool –
for blind rivet nuts up to
M12 steel!**

No. 145 0841



No. 152 4713

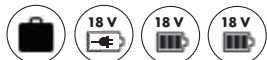

Setting force guide – Example: Steel M5

The values given are only guide values. The values should always be set slightly lower when setting for the first time!

TECHNICAL DATA

Weight: 2.4 kg with battery
Traction power: 20,000 N
Drive: brushless DC motor
Stroke: 10.0 mm



227

Power per battery charge,
threaded mandrels and
nosepieces **page 227.**

WORKING RANGE

Blind rivet nuts up to M12 alu and steel
and M10 stainless steel.

SCOPE OF DELIVERY

Threaded mandrel and nosepiece M6
(in working position),
Threaded mandrel and nosepiece M8
and M10 (in magazine)
1x Hexagonal wrench
1x Double open ended wrench SW 24/27
Card Quick adjustment
Card Setting force pre-adjustment
Operating manual



230

Spare parts, special accessories
for FireBird® Pro/FireBird® Pro
Gold Edition **page 230.**

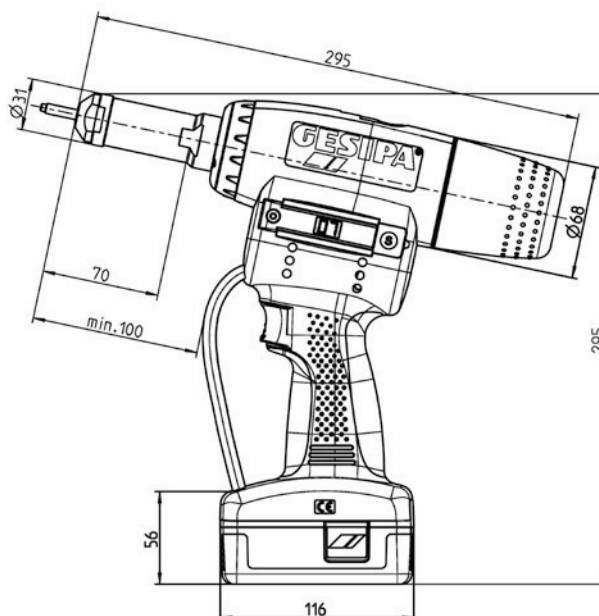

Dimensions in mm