

TAURUS® 4 SRB

TAURUS® 4 for lockbolts
6.4 mm (1/4") Magna-Grip®*

No. 145 0986

TAURUS® 4 for lockbolts
6.4 mm (1/4") C6L

No. 145 0985

*Registered trademark
of Alcoa Fastening Systems



TECHNICAL DATA

Weight:	2.2 kg
Operating air pressure:	5-7 bar
Schlauchanschluss:	6 mm Ø (1/4")
Air hose connection:	ca. 4.8 ltr. pro Niet
Setting force:	23,000 N at 6 bar
Stroke:	19 mm

WORKING RANGE

6.4 lockbolts MagnaGrip®* and C6L

SCOPE OF DELIVERY

1 hydraulic oil bottle 100 ml
1 oil refill can
Operating instructions with spare parts list
Hanger on tool head

! The suitability of nosepiece and fastener needs to be tested by the user and is user's own responsibility!

ADVANTAGES

- Specially adjusted stroke for setting lockbolts
- Very high tensile strength allows fast setting
- Extremely handy and lightweight due to its compact design
- Economic consumption of compressed air
- Minimum wear and tear due to use of pulling head modules with jaws respectively adjusted in their numbers of parts
- Efficient operation through extraction of spent mandrels
- Large spent mandrel container
- Attractive price-performance ratio
- Modular structure

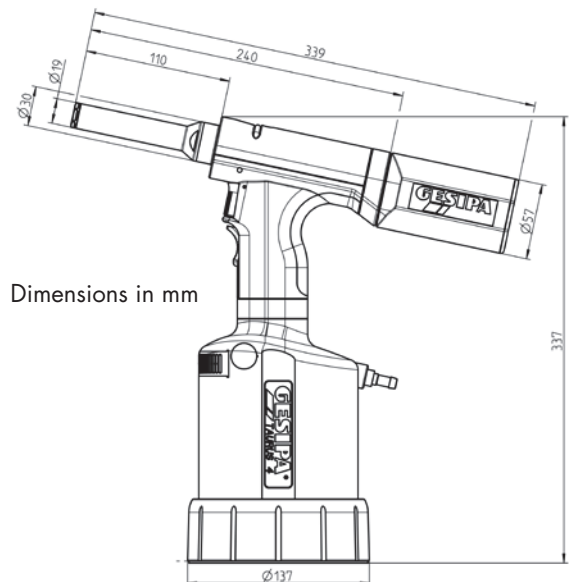

Dimensions in mm

JAW MECHANISM ASSIGNMENT

For lockbolts 6.4 mm (1/4") Magna-Grip®*

Designation	No.
Nosepiece	143 5942
Supporting ring	143 5943
Jaw	144 6105
Jaw housing	143 5997

For lockbolts 6.4 mm (1/4") C6L

Designation	No.
Nosepiece	143 5993
Supporting ring	143 5995
Jaw	144 6116
Jaw housing	143 5997