

TAURUS® 3 SRB

TAURUS® 3 For lockbolts 4.8 mm
Magna-Grip®

No. 145 0953

TAURUS® 3 for
lockbolts 4.8mm C6L

No. 145 0952

*Registered trademark
of Alcoa Fastening Systems

TECHNICAL DATA

Weight:	2.0 kg
Operating air pressure:	5 - 7 bar
Air hose connection Ø:	6 mm
Air consumption:	4.8 NL / stroke
Traction power:	18,000 N at 6 bar
Stroke:	25 mm

WORKING RANGE

4.8 lockbolts MagnaGrip®* and C6L

SCOPE OF DELIVERY

- 1 hydraulic oil bottle 100 ml
- 1 oil refill can
- Hanger on tool head
- Operating instructions with spare parts list

ADVANTAGES

- Specially adjusted stroke for setting lockbolts
- Very high tensile strength allows fast setting
- Extremely handy and lightweight due to its compact design
- Economic consumption of compressed air
- Minimum wear and tear due to use of pulling head modules with jaws respectively adjusted in their numbers of parts
- Efficient operation through extraction of spent mandrels
- Large spent mandrel container
- Attractive price-performance ratio
- Modular structure

JAW MECHANISM ASSIGNMENT

For lockbolts 4.8 mm Magna-Grip®

Designation	No.
Nosepiece	143 4810
Jaw	144 6118
Jaw housing	143 5945

For lockbolts 4.8 mm C6L

Designation	No.
Nosepiece	143 4809
Supporting ring	143 5995
Jaw	144 6117
Jaw housing	143 5944



! The suitability of nosepiece and fastener needs to be tested by the user and is user's own responsibility!

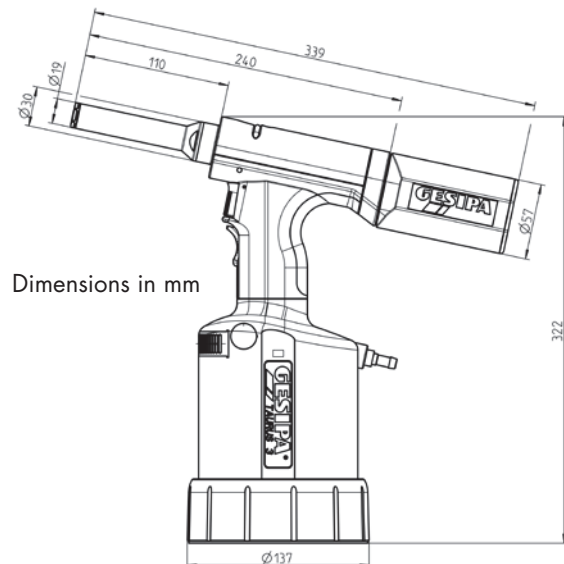

Dimensions in mm