

RANGE
2WD
2 WHEEL DRIVE



 **SCL924**
IN-LINE

SADEV
RACING TRANSMISSION

SADEV
RACING TRANSMISSION

RANGE
2WD
2 WHEEL DRIVE

SCL924

IN-LINE



With the SCL90, SADEV has accumulated experience and success in recent years.

To go even further and offer you an even more advanced product, our team of engineers has combined expertise and latest technological developments to create a new formidable gearbox: the SCL924. A very compact, strong, light and efficient product for high powered engines used in many applications such as GT, Off-road, Drift (...), while keeping overall cost in mind.

Mission accomplished ! The SCL924 meets all these criteria and is now a reference in its category.

APPLICATIONS

- › Circuit
- › Hill Climb
- › Drift
- › Rally





SCL924 IN-LINE

- › **Price:** The **SCL924** is recognised in the industry for its high quality and low price.
- › **Architecture:** In order to absorb extreme amounts of torque safely, the **SCL924** has an internal torsion bar system and a central bearing plate to prevent shaft deflection.
- › **Gears:** The **SCL924** benefits from optimised gear tooth profiles for maximum efficiency.
- › **Robustness:** Our finite element calculation tool enables us to design extremely strong, compact, lightweight casings.
- › **Cooling:** An oil pump built into the **SCL924** and driven mechanically enables an external oil cooler to be connected. The internal circuit and directed lubrication maintain the best operating temperature for optimum reliability.
- › **Weight:** The **SCL924** is one of the lightest gearboxes on the market that can handle such high power and torque levels.

MAXIMUM ENGINE TORQUE

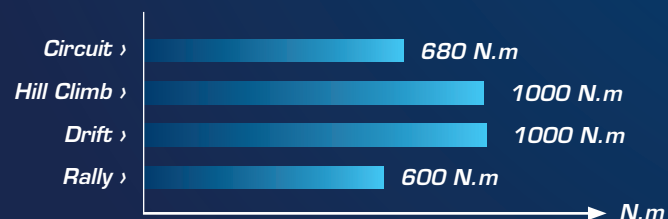

TECHNICAL SPECS

6 speed sequential gearbox + 1 reverse gear

Manual sequential gear selection

Wide range of final drives available

Wide range of ratios available

Straight cut gears

Gear engagement made by dogs

Interchangeable gear ratios

High strength carburizing steel

Gear teeth grinded with optimized profile

Shot penning on internal parts

Specific input shaft

Hydraulic clutch bearing

Reverse lockout cable (solenoid system optional)

Contactless gear position sensor

Flat shift sensor

Fittings to connect external oil cooler

Oil suction screen

Magnetic drain plugs

Casing joint faces sealed with O'rings

Internal lubrication ramp

Directed and pressurised lubrication on the gears

Lubrication lines through the casing

Integrated oil pump

Painted AS7G aluminum casings

Inspection bungs (optional)

Output flange for Lobro, 1315 or 1350 joint, BMW flector

Weight (input shaft included) : 38 Kg - 83 lbs

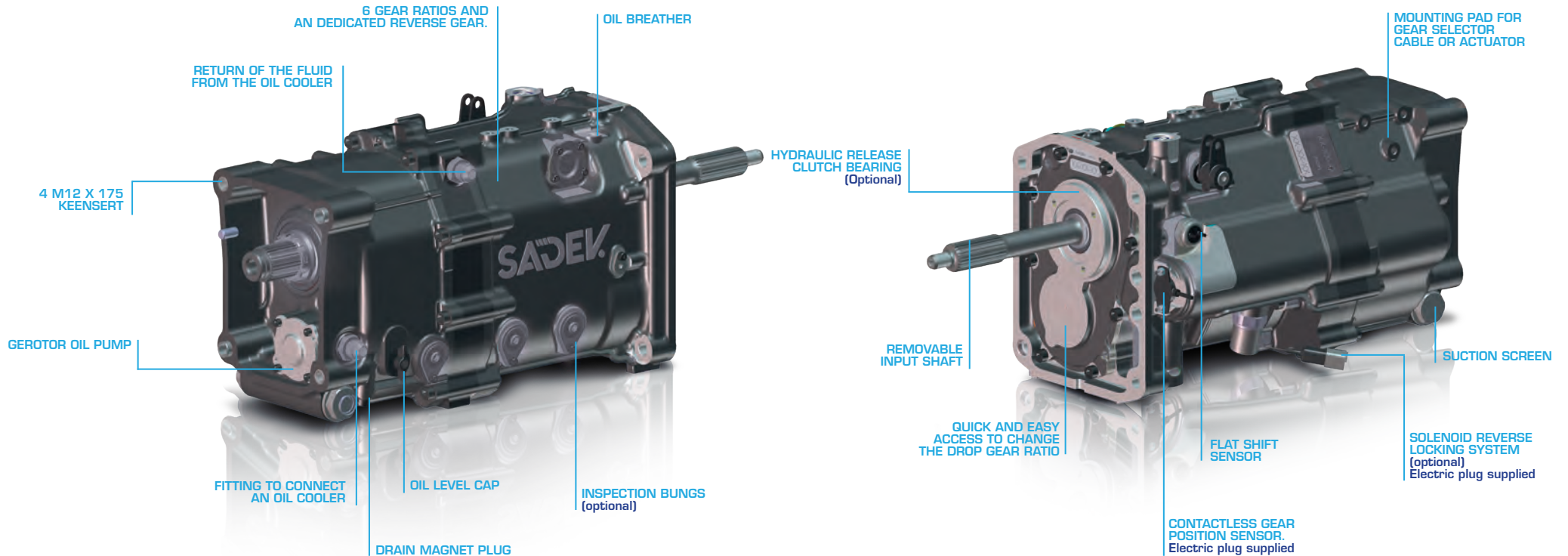

ACCESSORIES

- › Gear display
- › Mounting plate
- › Gearlever
- › Propshaft

DROP GEAR IS QUICKLY AND EASILY REMOVABLE FROM THE FRONT OF THE GEARBOX

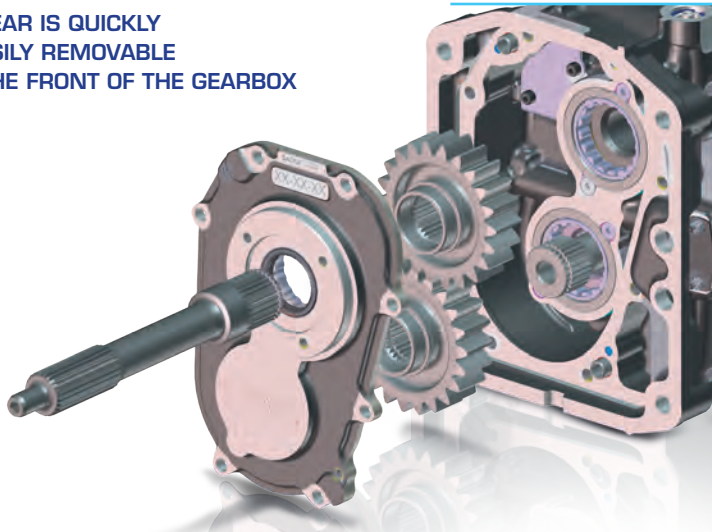

DIFFERENT OUTPUT FLANGES AVAILABLE

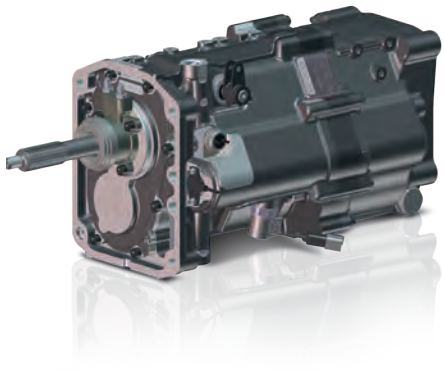

1315 U-JOINT
OUTPUT FLANGE

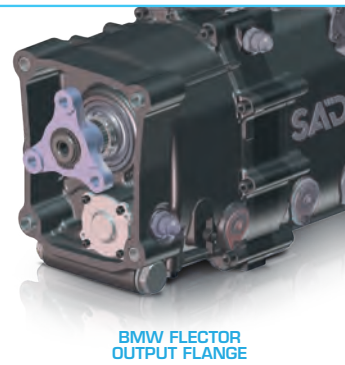

BMW FLECTOR
OUTPUT FLANGE

INTERMEDIATE BEARING CARRIER TO ENSURE MORE ROBUSTNESS

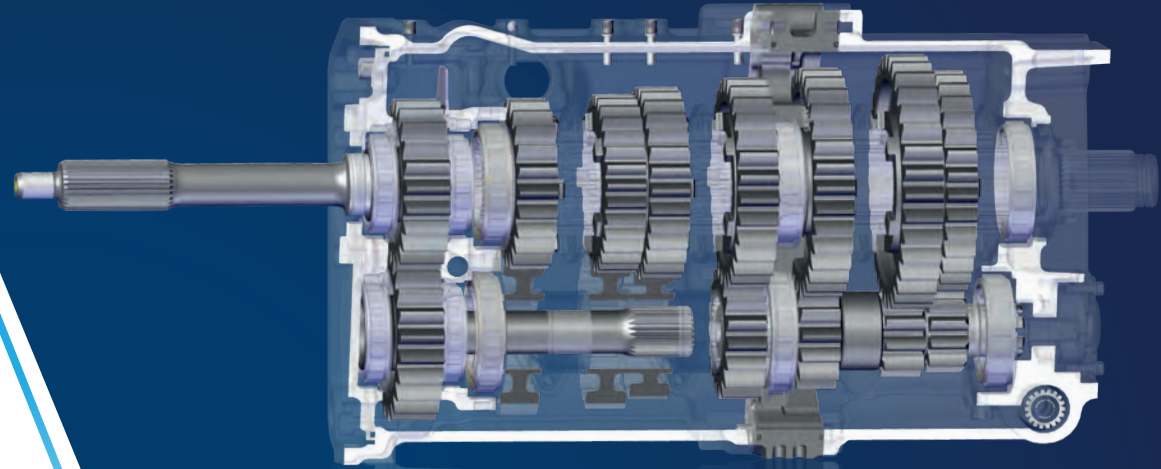

TORSION BAR TO ABSORB ENGINE TORQUE

HYDRAULIC PADDLE-SHIFT

Possibility to connect the SADEV paddle-shift system and to operate the transmission via an external actuator.

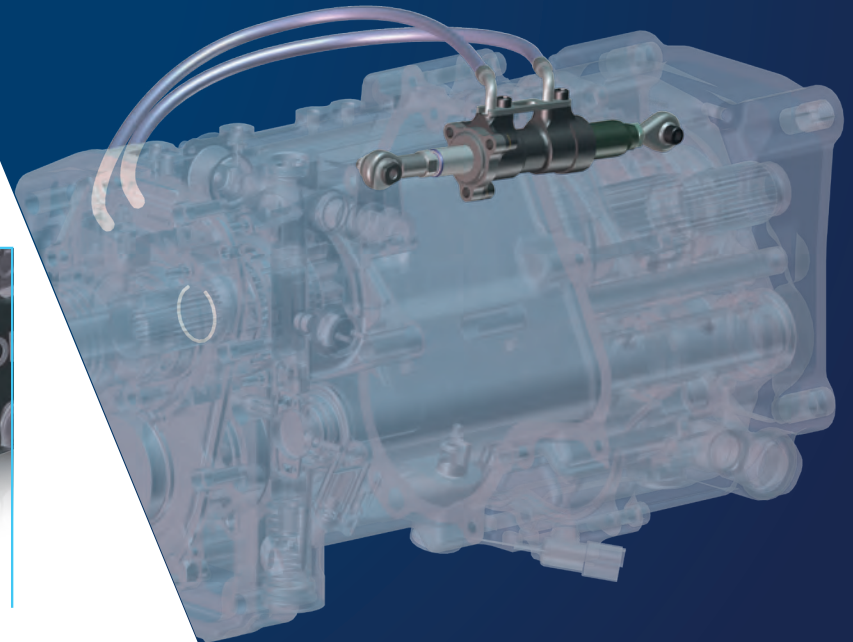



ONE PASSION : VICTORY

SADEV has an exceptional record in supplying unique engineering to the most prestigious drivers and manufacturers. SADEV's products stand out for their technology, their excellence and their ambition. As precise as they are reliable, these high-tech masterpieces are the key to your victory. SADEV has just one goal: to make sure you win.

FOLLOW US



WWW.SADEV-TM.COM

6, rue Grand'Montains - 85110 SAINT-PROUANT - FRANCE

Tel: +33 (0)2 51 66 42 68

sadev@sadev-tm.com



A TEAM AT YOUR SIDE

FRANCE	SADEV FRANCE - sadev@sadev-tm.com
USA	SADEV TRANSMISSIONS, INC. - info.usa@sadev-tm.com
UK	SWR MOTORSPORT LTD - serviceswrmotorsport@gmail.com
ITALY	GIEFFE RACING - info@giefferacing.com
SPAIN	DE LA PUENTE MOTORSPORT - dlpmotorsport@movistar.es
NETHERLANDS	RACING DEVELOPMENT - info@racingdevelopment.nl
NETHERLANDS	PETERS AUTOSPORT - bart@petersautosport.nl
BELGIUM	R TEC - info@rtec.ws
CZECH REPUBLIC	SADAC - info@sadac.cz
GERMANY	MTO ENGINEERING - info@mtoengineering.com
SWEDEN	HANSEN MOTORSPORT - kenneth@hansen-motorsport.se
DENMARK	GUNNAR AASKOV MOTORSPORT - mail@aaaskov-motorsport.dk
FINLAND	SET PROMOTION - kalle.pinomaki@setpromotion.com
SWITZERLAND	CHRISTIAN FERRARI - ferrach@bluewin.ch
SOUTH AFRICA	CENTURY RACING - julien@centuryracing.co.za
ARGENTINA	JPO RACING - racingjpo@gmail.com
BRAZIL	CD MOTORSPORT ENGINEERING - sadev.brasil@gmail.com
PORTUGAL	AUTO PAMPLONA, LDA - info@autopamplona.com