

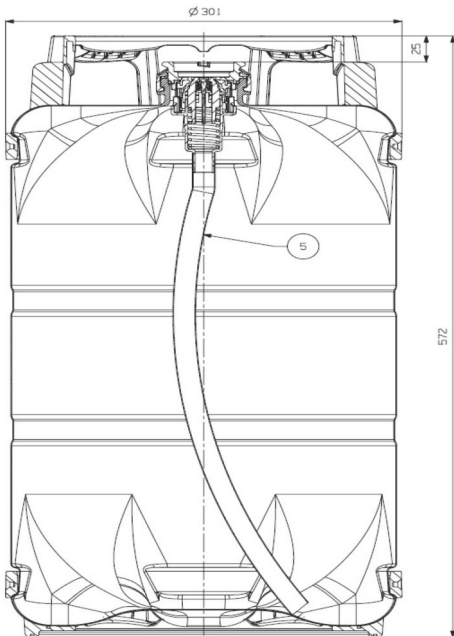

**PIONEER  
PACKAGING**

Seattle • Portland

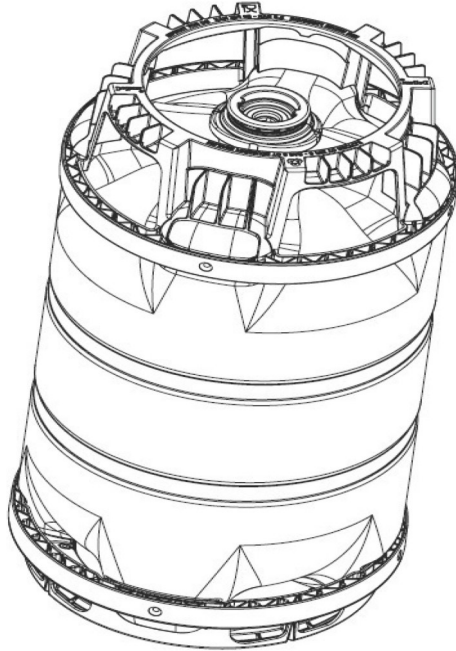

## DOLIUM 30L PRIME

### KEG

Cycle	single use
Volume	30L
Dimensions	D x H = 301 x 572mm
Weight (empty)	2.65 lbs
Temperature	32°F < T < 95°F
Pre-Pressure	1.0 bar CO <sub>2</sub>
Working Pressure	3.5 bar max
Pressure Relief Valve	5.2 bar +/- 0.2 bar
Kegs per Pallet	44 kegs

### CONTAINER

Oxygen Ingress	active barrier
Carbondioxide	passive barrier
UV Ingress	UV light barrier

### CONNECTION

Type	D(raft) type = American Sankey-type
------	--

### CHIMES

Handling Storage	vertical & horizontal stackable
---------------------	------------------------------------

### APPLICATIONS

Products	beverages
Shelf Life	equal to stainless steel
Certificates	FDA / EU
Filling Line	compatible—check recommended
Draught Installation	compatible
Recyclable	100%

**Dolium**  
THERE'S ONLY ONE WAY