



BATTERY SPECIFICATION

Nominal Voltage	12V
Number of cell	6
Design Life	5 years
Nominal Capacity 77°F(25°C)	
20 hour rate (0.45A, 10.5V)	9.00Ah
10 hour rate (0.82A, 10.5V)	8.20Ah
5 hour rate (1.54A, 10.5V)	7.70Ah
1 hour rate (5.80A, 9.6V)	5.80Ah
Internal Resistance	
Fully Charged battery 77°F(25°C)	≤18mOhms
Self-Discharge	
3% of capacity declined per month at 20°C(average)	
Operating Temperature Range	
Discharge	-20~60°C
Charge	-10~60°C
Storage	-20~60°C
Max. Discharge Current 77°F(25°C)	200A(5s)
Short Circuit Current	450A
Charge Methods: Constant Voltage Charge 77°F(25°C)	
Cycle use	2.40-2.45VPC
Maximum charging current	3.60A
Temperature compensation	-30mV/°C
Standby use	2.23-2.30VPC
Temperature compensation	-20mV/°C

DIMENSIONS AND WEIGHT

Length(mm / inch)	151 / 5.94
Width(mm / inch)	65 / 2.56
Height(mm / inch)	94 / 3.70
Total Height(mm / inch)	99 / 3.90
Approx. Weight(Kg / lbs)	2.50 / 5.52
* Weight deviation: ± 5%	

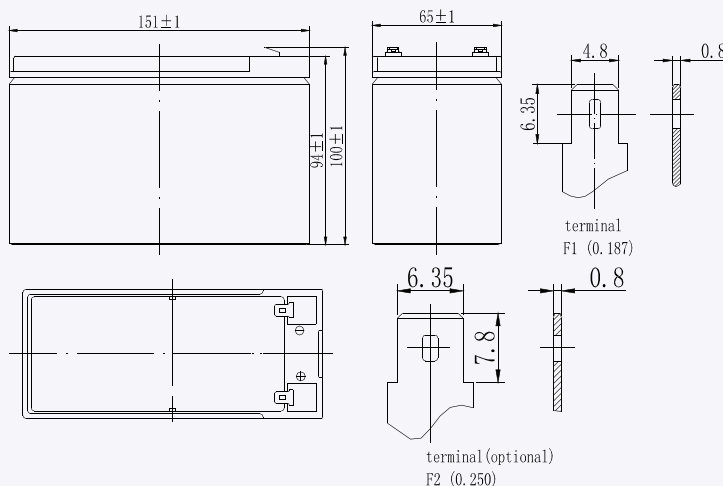

BATTERY CONSTRUCTION

Component	Positive plate	Negative plate	Container	Cover	Safety valve	Terminal	Separator	Electrolyte
Raw material	Lead dioxide	Lead	ABS	ABS	Rubber	Copper/Plug	Fiberglass	Sulfuric acid

DISCHARGE CONSTANT CURRENT (AMPERES AT 77°F/25°C)

End Point										
Volts/Cell	2min	5min	10min	15min	30min	1h	5h	10h	20h	
1.60V	70.0	41.0	24.2	18.0	9.90	5.80	1.60	0.87	0.47	
1.65V	63.0	39.0	23.6	17.5	9.79	5.75	1.56	0.86	0.46	
1.70V	59.8	38.7	22.9	16.1	9.36	5.71	1.55	0.84	0.46	
1.75V	54.8	36.4	22.1	14.6	8.91	5.66	1.54	0.82	0.45	
1.80V	48.7	33.2	21.0	13.9	8.45	5.51	1.53	0.82	0.44	

DISCHARGE CONSTANT POWER (WATTS AT 77°F/25°C)

End Point										
Volts/Cell	2min	5min	10min	15min	30min	1h	2h	3h	5h	
1.60V	118.3	76.6	49.3	37.3	22.1	12.8	6.30	4.34	3.10	
1.65V	112.1	73.6	48.3	36.8	21.9	12.7	6.23	4.29	3.04	
1.70V	108.3	72.5	48.0	36.6	21.8	12.6	6.08	4.20	2.98	
1.75V	100.8	69.0	46.6	35.8	21.6	12.5	5.94	4.08	2.92	
1.80V	92.5	64.5	44.3	34.5	21.2	12.4	5.77	3.92	2.85	

(Note)The above characteristics data are average values obtained within threecharge/discharge cycles. All data shall be changed without notice, Senzer reserves the right to explain and update the information.

GENERAL FEATURES

- Absorbent Glass Mat (AGM) technology for efficient gas recombination of up to 99% and freedom from electrolyte maintenance or water adding.
- Not restricted for air transport-complies with IATA/ICAO Special Provision A67.
- UL-recognized component.
- Can be mounted in any orientation.
- Computer designed lead, calcium tin alloy grid for high power density.
- Long service life, float or cyclic applications.
- Maintenance-free operation.
- Low self discharge.
- Case and cover available in both standard and flame retardant ABS.



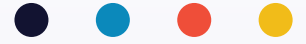

DISCHARGE CHARACTERISTICS CURVE

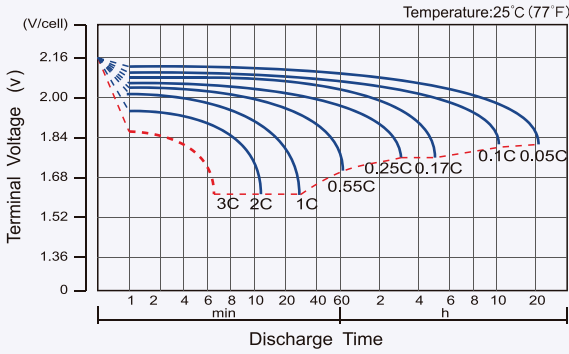

CHARGE CHARACTERISTIC CURVE FOR STANDBY USE

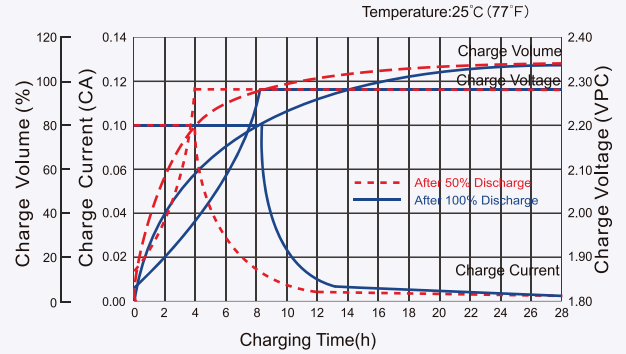

CYCLE LIFE IN RELATION TO DEPTH OF DISCHARGE

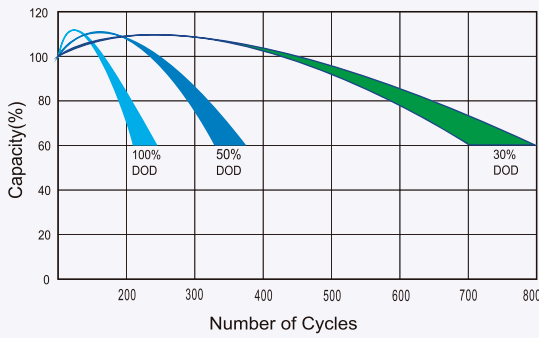

TEMPERATURE EFFECTS ON CAPACITY

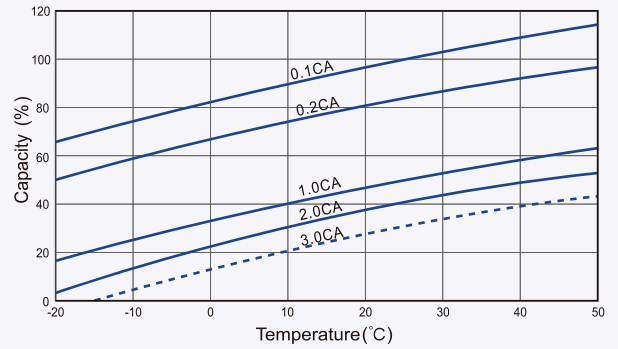

RELATIONSHIP BETWEEN CHARGING VOLTAGE AND TEMPERATURE

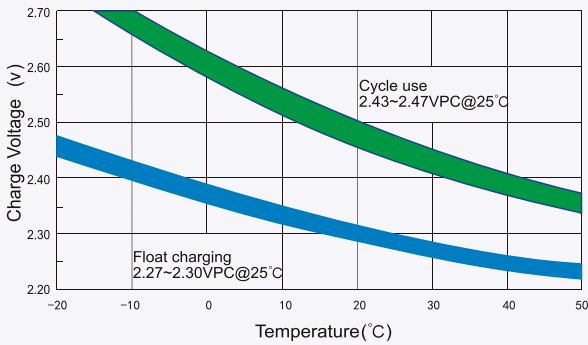

STORAGE CHARACTERISTICS

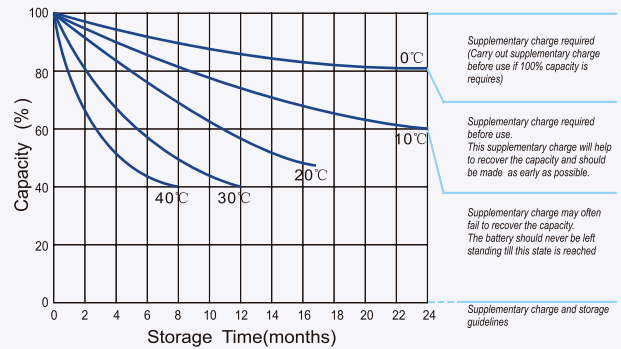

EFFECT OF TEMPERATURE ON LONG TERM LIFE

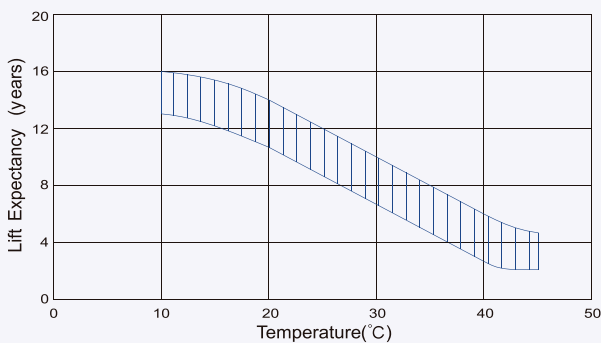

LIFE CHARACTERISTICS OF STANDBY USER

