



Known for Reliability Since 1921

The Biro HHP (Heavy Horse Power) Meat Grinders are a series of manual feed grinders with a range of bowl sizes and motor sizes that can be tailored to meet your grinding needs. With bowl sizes of 48, 52, or 56 and motor sizes of 5, 7.5, 10, or 15 hp (3.7, 5.6, 7.5, or 11.2 kw), we can provide a grinder that is just right for your application. All of the HHP series grinders feature single - reduction chain drive transmissions for maximum efficiency, and all the grinders use tapered roller bearings for low maintenance and long life. The HHP grinders have output capacities ranging from 1500 lbs. (680 kg) per hour to 7500 lbs. (3402 kg) so you can pick the model that fits best.



HHP Model 548SS
Shown.



HHP Model 1056SS
Shown.

**HEAVY HORSE POWER MANUAL FEED GRINDERS
5, 7.5, 10, 15 HORSE POWER SERIES**

MODEL HHP SPECIFICATIONS

MODEL:

548SS, 552SS, 7548SS, 7552SS, 1056SS, 1556SS Grinders (Chopper/Mincer).

CONSTRUCTION:

Stainless steel feed pan and polished stainless steel case,
Cast iron hot tin dipped bowl, ring, and auger.

FEED PAN ALL MODELS:

For 5, 7.5, 10, and 15 HP units - Left-Hand stainless steel high back feed tray is standard.

CAPACITY FEED PAN:

5 & 7.5 HP Approximately 100 lbs. (45 kgs.)
10 & 15 HP Approximately 115 lbs. (52 kgs.)

GRINDING CAPACITY: (APPROXIMATE)

548 & 7548 - 55 lbs. (25 kgs.) per minute (1ST grind, 3/8" plate)
& 33 lbs. (15 kgs.) per minute (2ND grind, 1/8" plate).

552 & 7552 - 70 lbs. (32 kgs.) per minute (1ST grind, 3/8" plate)
& 40 lbs. (18 kgs.) per minute (2ND grind, 1/8" plate).

1056 & 1556 - 125 lbs. (57 kgs.) per minute (1ST grind, 3/8" plate)
& 80 lbs. (36 kgs.) per minute (2ND grind, 1/8" plate).

SWITCH:

Watertight magnetic type with thermal overload and under voltage protection.

POWER CORD:

Option at (EC). Specify length.

DRIVE SYSTEM:

Silent (10-15 HP) or Roller link (5, 7.5 HP) chain drive over wide face sprockets insuring maximum power transfer from motor to auger.

BEARINGS:

Deep tapered roller thrust bearings carry all radial and thrust loads from auger eliminating friction.

SAFETY:

Magnetic safety interlock so machine will not operate when feed pan with welded bowl guard is removed.

STANDARD FEATURES:

Aluminum legs on 5 & 7.5 HP • Plated Steel legs on 10 & 15 HP • spurt guard
• stomper • ring wrench • bowl guard on feed pan • operating and safety manual.

OPTIONS (EC):

Size 32, 52, 56 knives and plates • longer legs aluminum or steel with cross bracing • various motors (see chart) • solid stomper • connections for mixer-grinder system • Goodyear Eagle herringbone belt system • right-hand stainless steel high back feed trays available on request • power cord (specify length).

CERTIFICATIONS:

U.L., N.S.F., U.S.D.A., C.S.A.

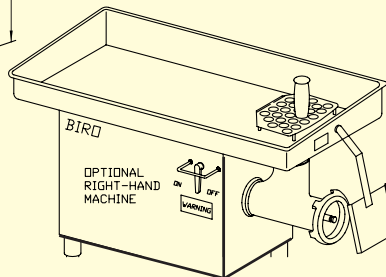
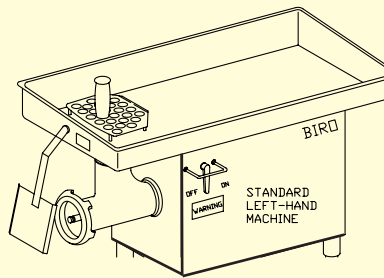
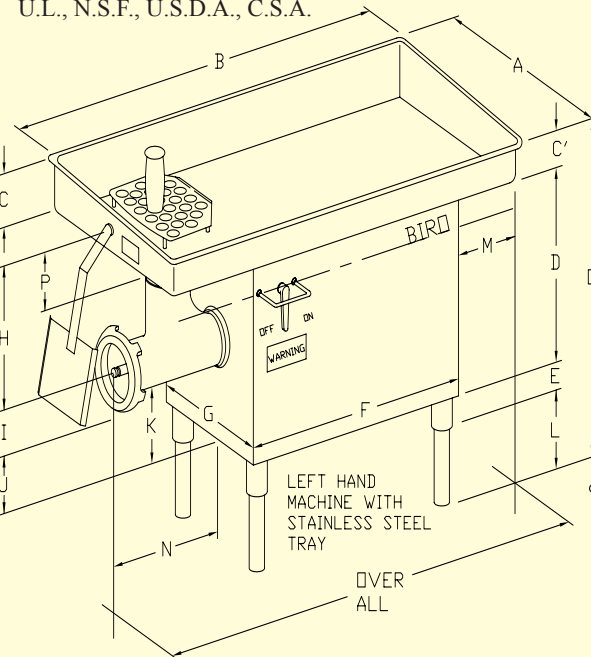

MOTORS:

BOWL	HP	KW	VOLTS	AMPS	CYCLE	PH	STATUS
48/52	5	3.7	208-220/440	17-16/8	60	3	STD
48/52	5	3.7	208-230	29-27	60	1	EC
48/52	5	3.7	550-575	6.4-6	60	3	EC
48/52	5	3.7	220/380-415	19.2/11-10	50	3	NC
48/52	7.5	5.6	208-220/440	23-22/11	60	3	STD
48/52	7.5	5.6	550-575	8.8-8.4	60	3	EC
48/52	7.5	5.6	220	26.4	50	3	NC
48/52	7.5	5.6	380-415	15.3-14	50	3	NC
56	10	7.5	208-220/440	27-25.6/12.8	60	3	STD
56	10	7.5	550-575	10-9.6	60	3	EC
56	10	7.5	220/380-415	30.7/17.8-16.3	50	3	NC
56	15	11.2	208-220/440	41-39/19.5	60	3	STD
56	15	11.2	550-575	15.6-14.9	60	3	EC
56	15	11.2	220/380-415	46.8/27-24.8	50	3	NC

STD = STANDARD 48 BOWL ACCEPTS SIZE 32 PLATES AND KNIVES - EC
EC = EXTRA COST 52 BOWL ACCEPTS SIZE 52 PLATES AND KNIVES - EC
NC = NO CHARGE 56 BOWL ACCEPTS SIZE 56 PLATES AND KNIVES - EC

DIMENSIONS	548	552	1056
	INCH (MM)	7548	7552
A	29 (737)	29 (737)	29 (737)
B	52 (1321)	52 (1321)	52 (1321)
C	8-5/8 (219)	8-5/8 (219)	8-5/8 (219)
C'	4-1/4 (108)	4-1/4 (108)	4-1/4 (108)
D	27-1/4 (692)	27-1/4 (692)	32-1/4 (819)
E	2-3/4 (70)	2-3/4 (70)	2-3/4 (70)
F	30-1/4 (768)	30-1/4 (768)	33-1/4 (845)
G	18-15/16 (481)	18-15/16 (481)	22-1/2 (571)
H	11 (279)	11 (279)	12-1/8 (308)
I	4-1/4 (108)	4-1/4 (108)	5-1/8 (130)
J	12-3/8 (314)	11-3/4 (298)	15-5/8 (396)
K	14-1/2 (368)	14-1/2 (368)	17-3/4 (451)
L	8-1/4 (210)	8-1/4 (210)	3-1/4 (83)
M	5 (127)	5 (127)	2-1/2 (63)
N	17-1/2 (444)	17-1/4 (438)	21 (533)
O	42-3/4 (1086)	42-3/4 (1086)	42-3/4 (1086)
P	2-1/2 (63)	2-1/2 (63)	3-1/2 (89)
OA	55 (1397)	55 (1397)	58-3/4 (1492)
WEIGHT PACKED	510 (232)	520 (236)	705 (320)
WEIGHT UNPACKED	430 (195)	440 (200)	621 (282)

WEIGHTS APPROXIMATED, lbs. (kgs)

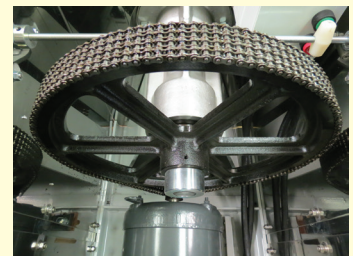

Biro exclusive non-slip chain drive transmission.

BIRO MANUFACTURING COMPANY
1114 WEST MAIN STREET
MARBLEHEAD, OH 43440-2099 U.S.A.
Phone: (419) 798-4451
Fax: (419) 798-9106
www.birosaw.com
sales@birosaw.com

ITEM NO.: LIT-HHP-065
FORM NO.: Md HHP-065-8-16-39-B

All specifications contained herein are subject to change without notification.

Service is available from locations worldwide