

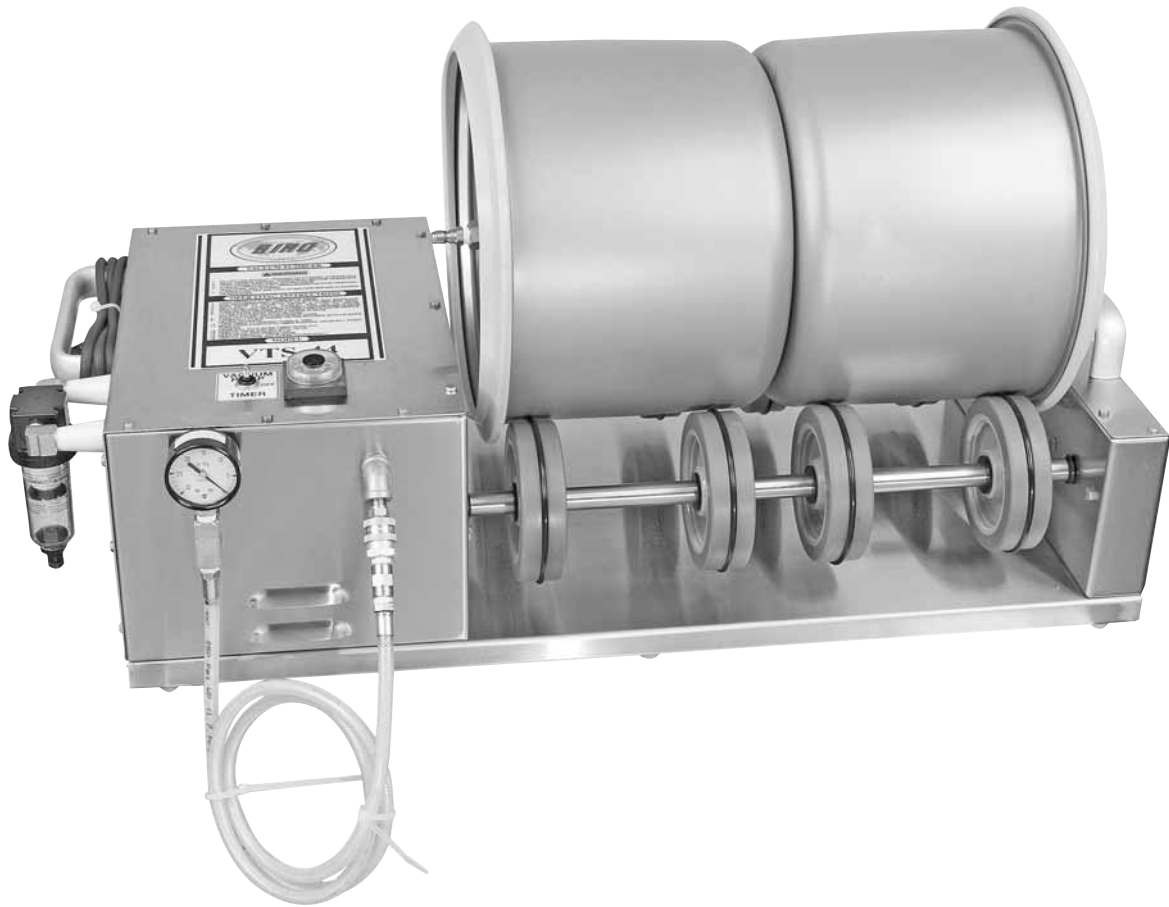

**DOUBLE DRUM
VACUUM TUMBLER
OPERATION MANUAL & PARTS LIST
MODEL VTS-44
SELF CONTAINED PUMP**



The **BIRO VTS-44 VACUUM TUMBLER** is a versatile machine used for vacuum tumbling all types of meats. The **BIRO VTS-44** will produce equally impressive results with beef, pork, poultry and fish.

The unit is both easy to clean and maintain as well as sanitary in design and construction. The entire machine is built to give many years of trouble free service while providing a unique line of marinated products for your customers.

TABLE OF CONTENTS

	Page
NOTICE TO OWNERS AND OPERATORS	1
SAFETY TIPS	2
OPERATION	3
TO PROCESS PRODUCT	3-4
INSTRUCTIONS FOR PULLING A VACUUM	5
PARTS DIAGRAMS	6-9
FILTER MAINTENANCE INSTRUCTIONS	8 & 10
VACUUM PUMP INSTRUCTIONS	11
WIRING DIAGRAM	12
MAINTENANCE	13
CLEANING	14
OPERATOR'S NOTES	15
OPERATOR'S SIGNATURE PAGE	16
LIMITED WARRANTY	17

NOTICE TO OWNERS AND OPERATORS

BIRO's products are designed to process food products safely and efficiently. Unless the operator is properly trained and supervised, however, there is the possibility of a serious injury. It is the responsibility of the owner to assure that this machine is used properly and safely, strictly following the instructions contained in this Manual and any requirements of local law.

No one should use or service this machine without proper training and supervision. All operators should be thoroughly familiar with the procedures contained in this Manual. Even so BIRO cannot anticipate every circumstance or environment in which its products will be used. You, the owner and operator, must remain alert to the hazards posed by the function of this equipment. No one under eighteen (18) years of age should operate this equipment. If you are uncertain about a particular task, ask your supervisor.

This Manual contains a number of safe practices in the SAFETY TIP section. Additional warnings are placed throughout the Manual. Warnings related to your personal safety are indicated by:



OR



Warnings related to possible damage to the equipment are indicated by:



BIRO also has provided warning labels on the equipment. If any warning label, instruction label or Manual becomes misplaced, damaged, or illegible, please contact your nearest Distributor or BIRO directly for a replacement.

Remember, however, this Manual or the warning labels do not replace the need to be alert and to use your common sense when using this equipment.

– NOTE –

A copy of this manual is included with each MODEL VTS-44 VACUUM TUMBLER.

**The descriptions and illustrations contained in this manual are not binding.
The manufacturer reserves the right to introduce any modification without updating the manual.**

SAFETY TIPS



ROTATING DRUM TO AVOID SERIOUS PERSONAL INJURY

NEVER Touch This Machine Without Training and Authorization By Your Supervisor.

ALWAYS Read Operation and Service Manual **BEFORE** Operating, Cleaning or Servicing.

ALWAYS Keep Hands Clear of the Rotating Drum and Other Moving Parts.

NEVER Attempt to Remove the Drum Lid Unless Vacuum Has Been Released and the Drum is Positioned Vertically with the Lid at the Top.

NEVER Operate Vacuum Pump Unless Properly Connected to Tumbler Drum.

ONLY Operate Vacuum Pump in Recommended Vacuum Range (15-20 Inches of Mercury)
NEVER TO EXCEED 20 INCHES Hg.

ONLY Use a Qualified Electrician to Install According to Local Building Codes: Machine **MUST** Be Properly Grounded.

ONLY Install on Level, Non-Skid Surface in a Clean, Well-Lighted Work Area Away From Children and Visitors.

DO NOT Store or Operate Machine in Meat Cooler.

DO NOT Allow Food Particles, Liquids or Any Other Foreign Material to Enter the Vacuum Pump or Vacuum Hose.

ALWAYS Turn Off, Unplug From Power Source and Perform Lockout/Tagout Procedure to This Machine **BEFORE** Attempting to Unjam or Unclog, Cleaning or Servicing.

NEVER Leave Machine Unattended While Operating.

PROMPTLY REPLACE Any Worn or Illegible Warning and/or Instruction Labels.

USE ONLY BIRO Parts and Accessories Properly Installed.

NEVER Use the Motor Box Cover for Preparing Product.

OPERATION



ROTATING DRUM TO AVOID SERIOUS PERSONAL INJURY

ONLY Properly Trained Personnel Should Use This Equipment.

ALWAYS Keep Hands Clear of the Rotating Drum and Other Moving Parts.

DO NOT Tamper With, Bypass, Alter, or Modify This Equipment in Any Way From Its Original Condition.

ALWAYS Turn Off, Unplug From Power Source and Perform Lockout/Tagout Procedure to This Machine Before Cleaning, Servicing, or When Not In Use.

NEVER Leave Unattended While Operating.

DO NOT Store or Operate Machine in Meat Cooler.

NEVER Operate Without All Warning or Instruction Labels Attached.

NEVER Use the Motor Box Cover for Preparing Product.

A. FOOD HANDLING TO PREVENT CONTAMINATION

1. **ALWAYS** wash hands thoroughly with warm soap and water before and after handling raw fish, poultry or meats.
2. **ALWAYS** clean and sanitize all utensils and surfaces that have been in contact with raw products.
3. **ALWAYS** store cold foods at or below 45 deg. F (7.2 deg. C).

B. TO PROCESS PRODUCT

1. Insert baffles into Stainless Steel drum. Be sure that baffles are fully engaged on mounting buttons.
2. Weigh product to be vacuum tumbled.
3. Refer to your ingredient chart for proper amount of marinade seasoning and water.
4. Place product, marinade and water into tumbler drum.
5. Install gasket on drum lid and place lid on drum.
6. Connect vacuum hose to valve on drum lid. Be sure valve handle is in the open position, parallel with the valve body.
7. Plug vacuum pump into a grounded 60HZ: 115 volt, 10 amp **OR** 50HZ: 220 volt, 5 amp power source. Turn vacuum pump to "ON" while pressing down on the center of the lid. (Vacuum gauge will start indicating a vacuum is being pulled in the drum.) If needle in vacuum gauge does not indicate vacuum is being pulled, turn "OFF" vacuum pump and disconnect vacuum hose from drum lid. Remove drum lid and check that the lid gasket is properly installed and seated.

8. When vacuum gauge does indicate that a vacuum is being pulled, allow to continue running until gauge reads between 15 and 20 inches Hg. **NEVER EXCEED 20 Hg.**
9. Close valve handle on drum lid, Perpendicular to valve body. Turn vacuum pump to "OFF" position and unplug from power source. Remove vacuum hose from valve. Drum contents are now sealed in a vacuum.
10. Lay drums horizontally on roller with lid ends facing away from each other.
11. Plug tumbler motor into a grounded 60H:Z 115 volt, 10 amp **OR** 50 HZ: 220 volt, 5 amp power source and turn toggle switch to "ON" position.
12. Turn timer control dial to desired time, and turn toggle switch to "ON TIMER" position.
13. When drum stops turn toggle switch to "OFF" position, unplug tumbler motor from power source.
14. Remove drums and place on table with lids up. Turn valve handle to open position Parallel with valve body to release vacuum. Remove drum lids.
15. Remove product from drum.

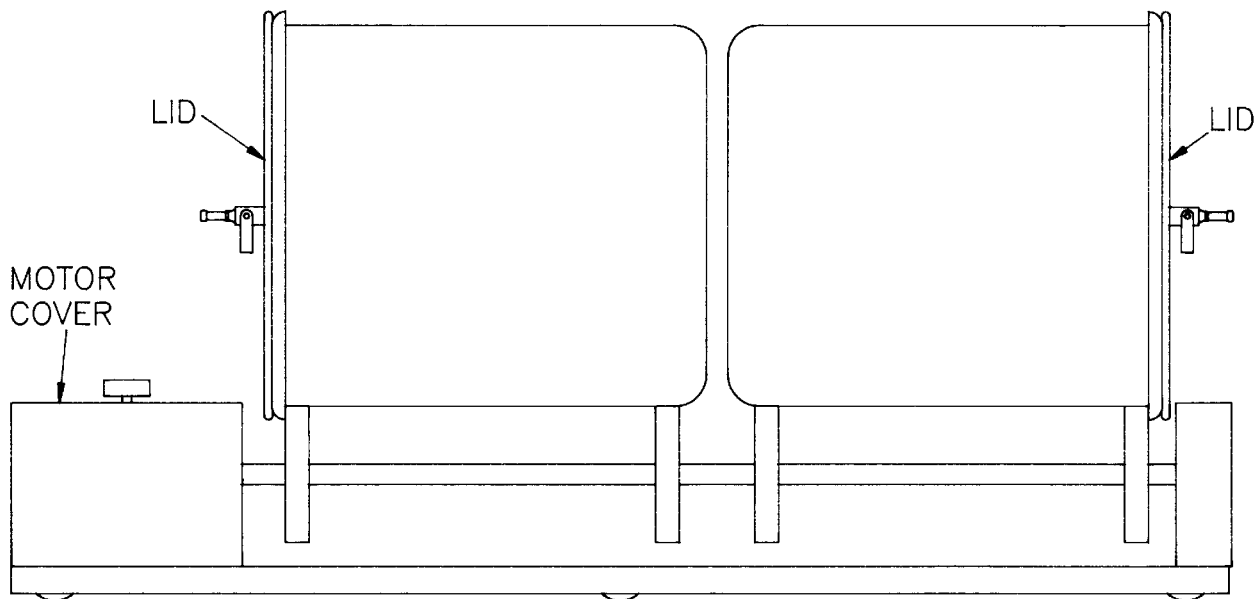

INSTRUCTIONS FOR PULLING A VACUUM

The following guidelines should be followed when using **BIRO** vacuum tumblers. Due to the nature of the manufacturing processes by which these drums and lids are made, there are slight differences in the diameter of the drum opening, and the diameter of the lid. These differences are normal, and have no impact on the performance of your tumbler.

- ✓ Make sure that the lid gasket is sealed properly.
- ✓ Center the lid in the opening of the drum.
- ✓ Start the vacuum pump.
- ✓ Apply pressure in the center of the lid.

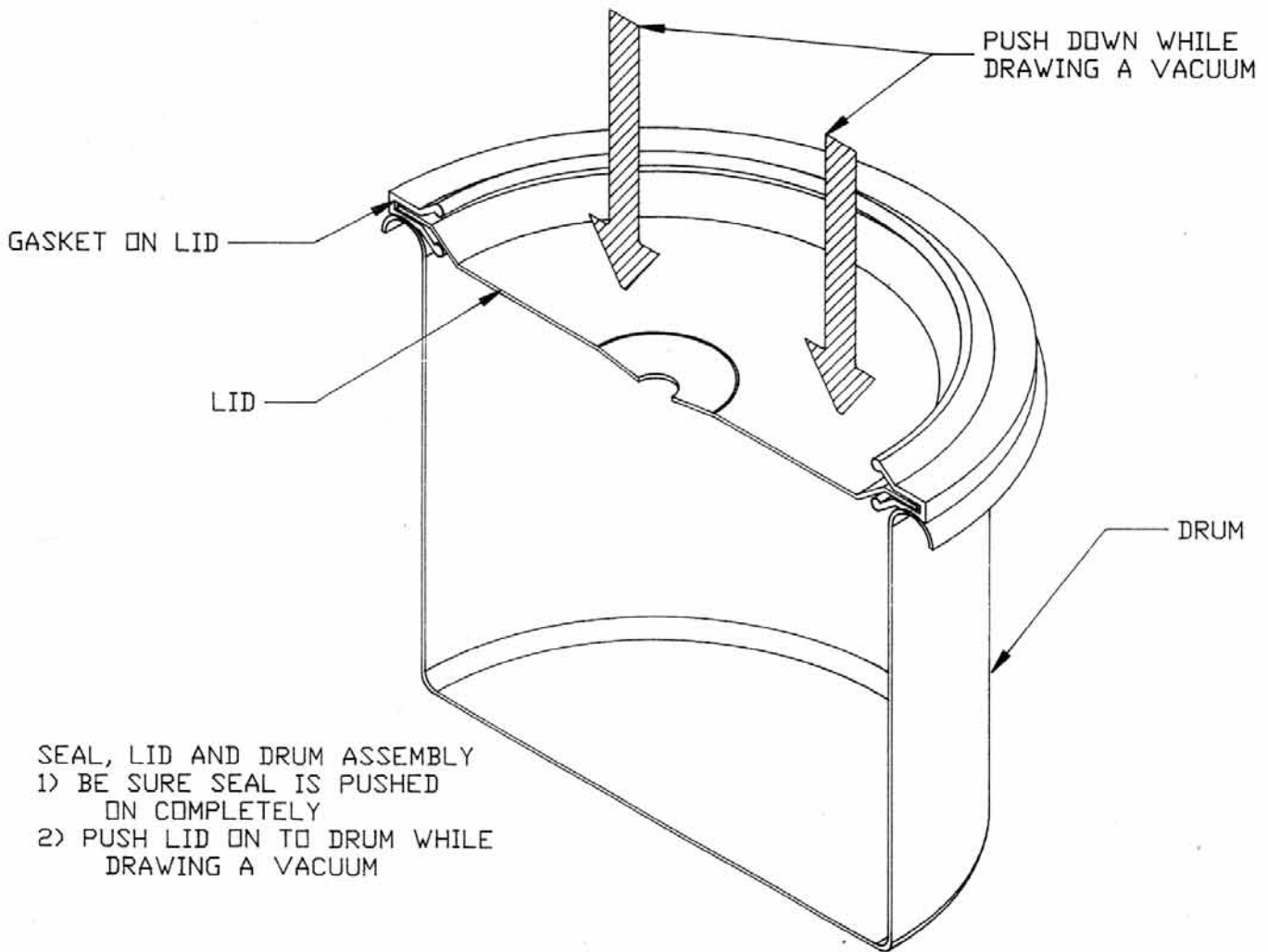

VTS-44

IMPORTANT: Always Advise Model & Serial Number When Ordering Parts

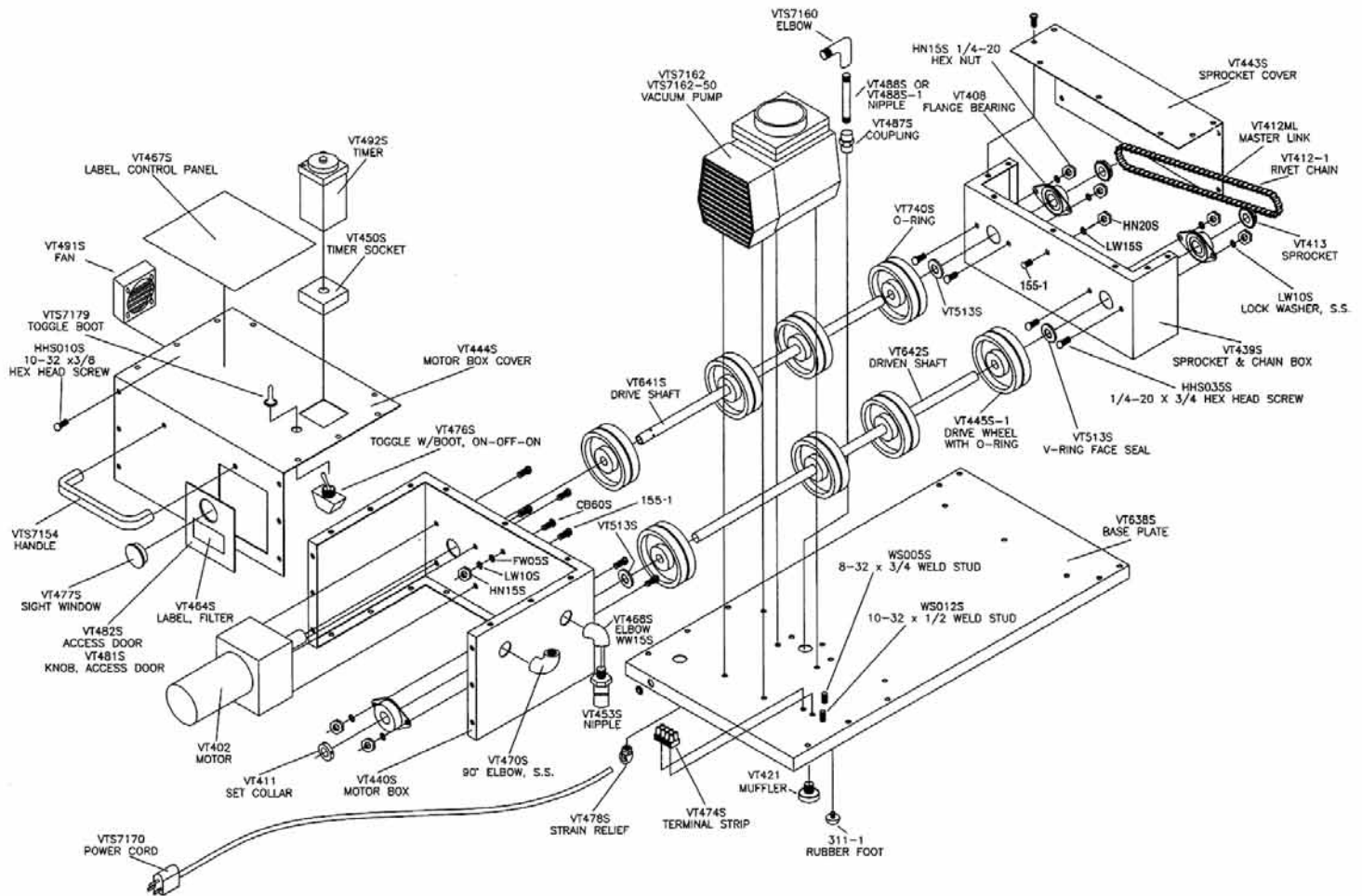

Part No.	Description
155-1	Guide for 16" high drum
311-1	Rubber foot
CB60S	Carriage bolt 1/4-20 x 1/2 SS
FW05S	Flat washer 1/4 SS
FW10S	Flat washer 5/16 SS
HHS010S	Hex head screw, 10-32 x 3/8 SS
HHS035S	Hex head screw, 1/4-20 x 5/8 SS
HN15S	Hex nut, 1/4-20
HN20S	Hex nut 5/16 -18 SS heavy
LW10S	Lock washer, 1/4 SS
LW15S	Lock washer, 5/16 SS reg.
VT402	Motor, 1/25HP, 115-60-1, 17.7RPM. 90:1
VT408	Flange Bearing
VT411	Set collar
VT412-1	Rivet chain
VT412ML	Master link
VT413	Sprocket
VT439S	Sprocket & chain box less cover
VT440S	Motor & pump box less cover
VT443S	Sprocket & chain cover
VT444S	Motor & pump cover
VT445S-1	Drive wheel, with O-ring
VT450S	Timer socket
VT453S	Nipple - quick coupler
VT464S	Label, filter
VT468S	Elbow 45° x 1/4 FPT x 1/4 FPT
VT470S	Elbow, 90 deg., 1/4 FPT, SS

Part No.	Description
VT474S	Terminal strip, 4 circuit
VT476S	Toggle switch w/boot, ON-OFF-ON
VT477S	Sight window
VT478S	Strain relief, 90 deg.
VT481S	Knob, access door
VT482S	Access door
VT487S	Coupling 1/4 FPT brass
VT488S-1	Nipple 6 1/2" x 1/4 MPT brass
VT491S	Ventilation fan
VT492S	Timer without pushbutton start, 0 - 50 minute
VT513S	Shaft seal
VT638S	Tumbler base plate
VT641S	Driving shaft, double drum
VT642S	Driven shaft, double drum
VT660S	Label, VTS-44 control panel
VTS7154	Oval handle
VTS7160	90° street 1/4 MPT x 1/4 FPT brass
VTS7162	Vacuum pump, 115-60-1
VTS7162-50	Vacuum pump, 220-50-1
VTS7170	Power cord w/120V plug, 8', 16/3
VTS7179	Toggle switch boot
VT740S	O-ring
WW15S	Wrought washer 5/16 x 1 1/4 O. D.

INTERNAL FILTER ASSEMBLY

IMPORTANT: Always Advise Model & Serial Number When Ordering Parts

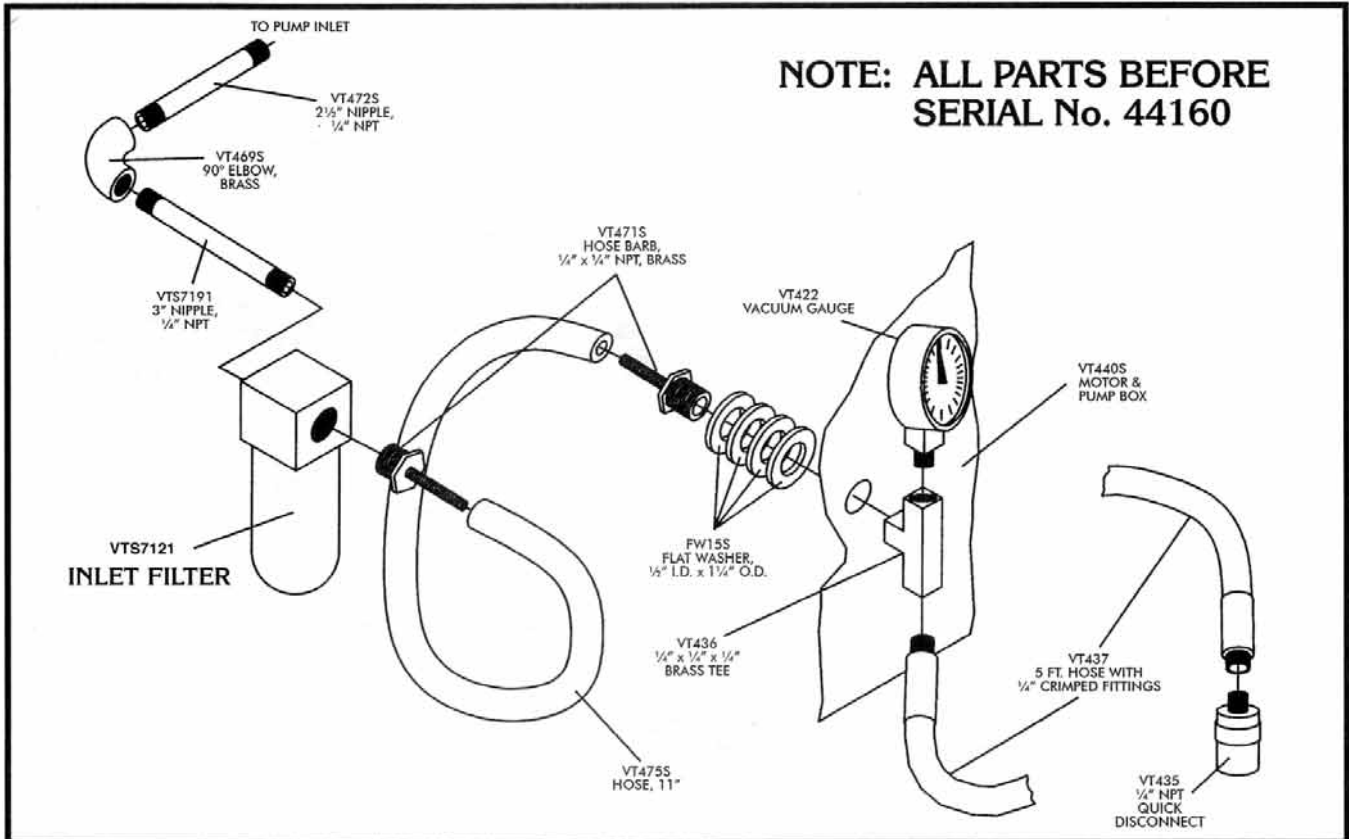

NOTE: ALL PARTS BEFORE SERIAL No. 44160

Part No.	Description	Part No.	Description
FW15S	Flat washer 1/2 I.D. x 1 1/4 O.D.	VT469S	Elbow, 90 deg. 1/4 FPT, brass
WW15S	Flat washer, 3/16, SS	VT470S	Elbow, 90 deg, 1/4 FPT, SS
VT422	Vacuum gauge	VT471S	Hose barb, 1/4 x 1/4, brass
VT435	Coupler, 1/4 MPT	VT472S	Nipple, 2 1/2, 1/4 NPT
VT436	Tee, 1/4 x 1/4 x 1/4 FPT, brass	VT475S	Vacuum hose, 11"
VT437	Hose, 5' with 1/4 MPT crimped ends	VT57121	Inlet filter
VT440S	Motor & pump box less cover	VT57191	Pipe nipple, 3" long x 1/4 MPT, brass

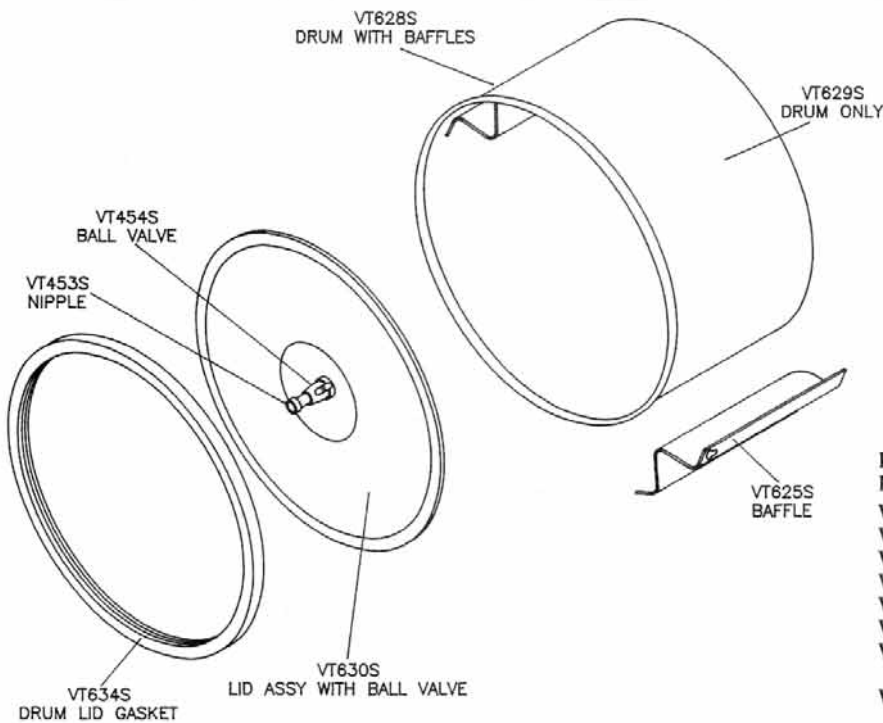

VT635S DRUM ASSEMBLY

Part No.	Description
VT453S	Nipple only
VT454S	Ball valve, only
VT625S	Baffle, double drum
VT628S	Drum with baffles
VT629S	Drum only, w/o baffles
VT630S	Lid assembly with ball valve
VT634S	Drum lid gasket, double drum, white
VT635S	Drum assembly

No. VTS7121 INTERNAL FILTER DRAINING INSTRUCTIONS

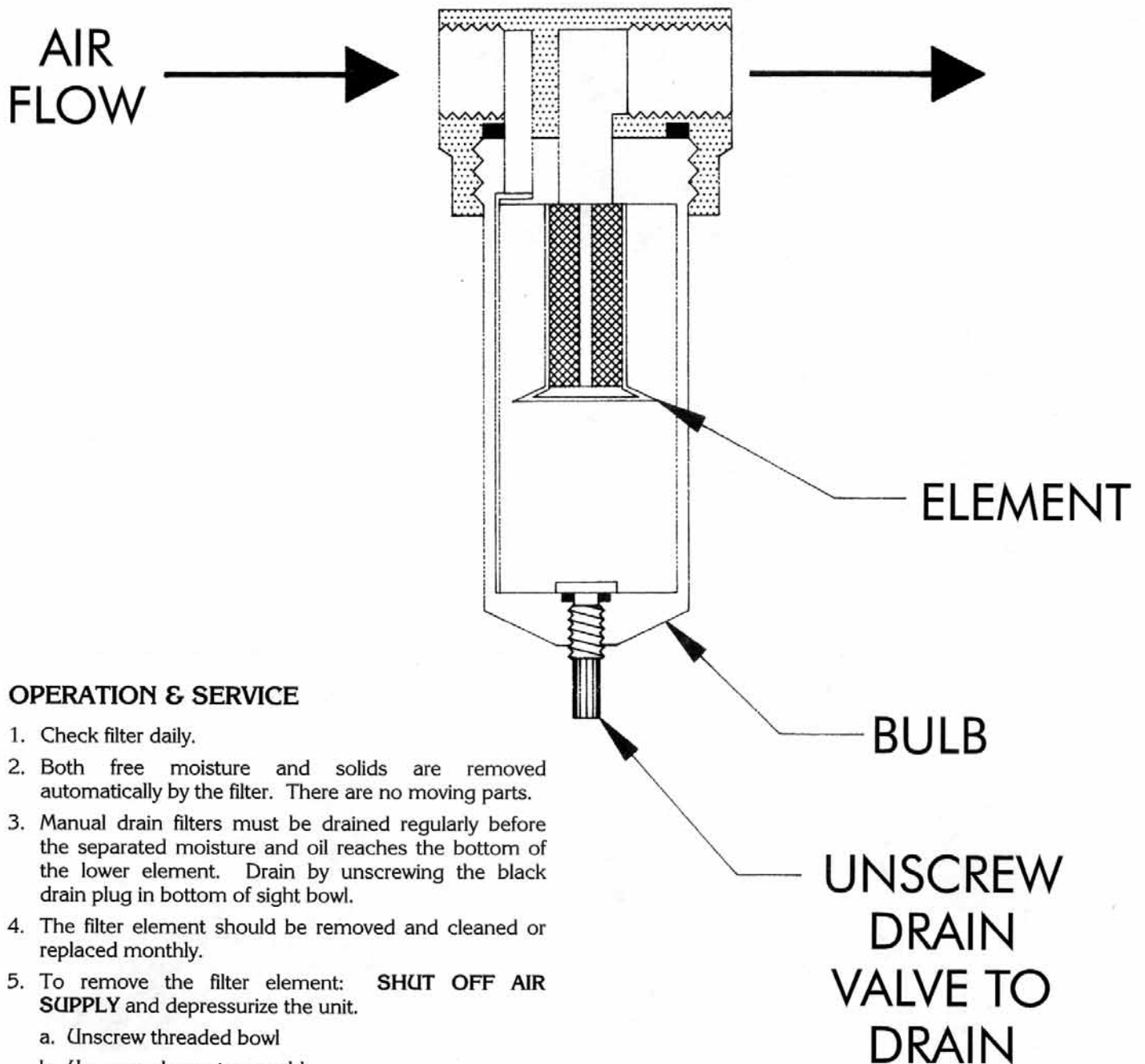

OPERATION & SERVICE

1. Check filter daily.
2. Both free moisture and solids are removed automatically by the filter. There are no moving parts.
3. Manual drain filters must be drained regularly before the separated moisture and oil reaches the bottom of the lower element. Drain by unscrewing the black drain plug in bottom of sight bowl.
4. The filter element should be removed and cleaned or replaced monthly.
5. To remove the filter element: **SHUT OFF AIR SUPPLY** and depressurize the unit.
 - a. Unscrew threaded bowl
 - b. Unscrew element assembly
 - c. Clean bowl and filter element. Reassemble or replace filter element. Clean bowl with mild soap and water only. Do not use detergents, cleansing agents, such as acetone, alcohol, benzene or gasoline, which are damaging to plastic.
 - d. Lubricate or replace bowl gasket to assist initial sealing. Use only mineral based oils or grease. Do not use synthetic oils or silicones.
 - e. Screw bowl into body of filter. Close black drain plug.

EXTERNAL FILTER ASSEMBLY

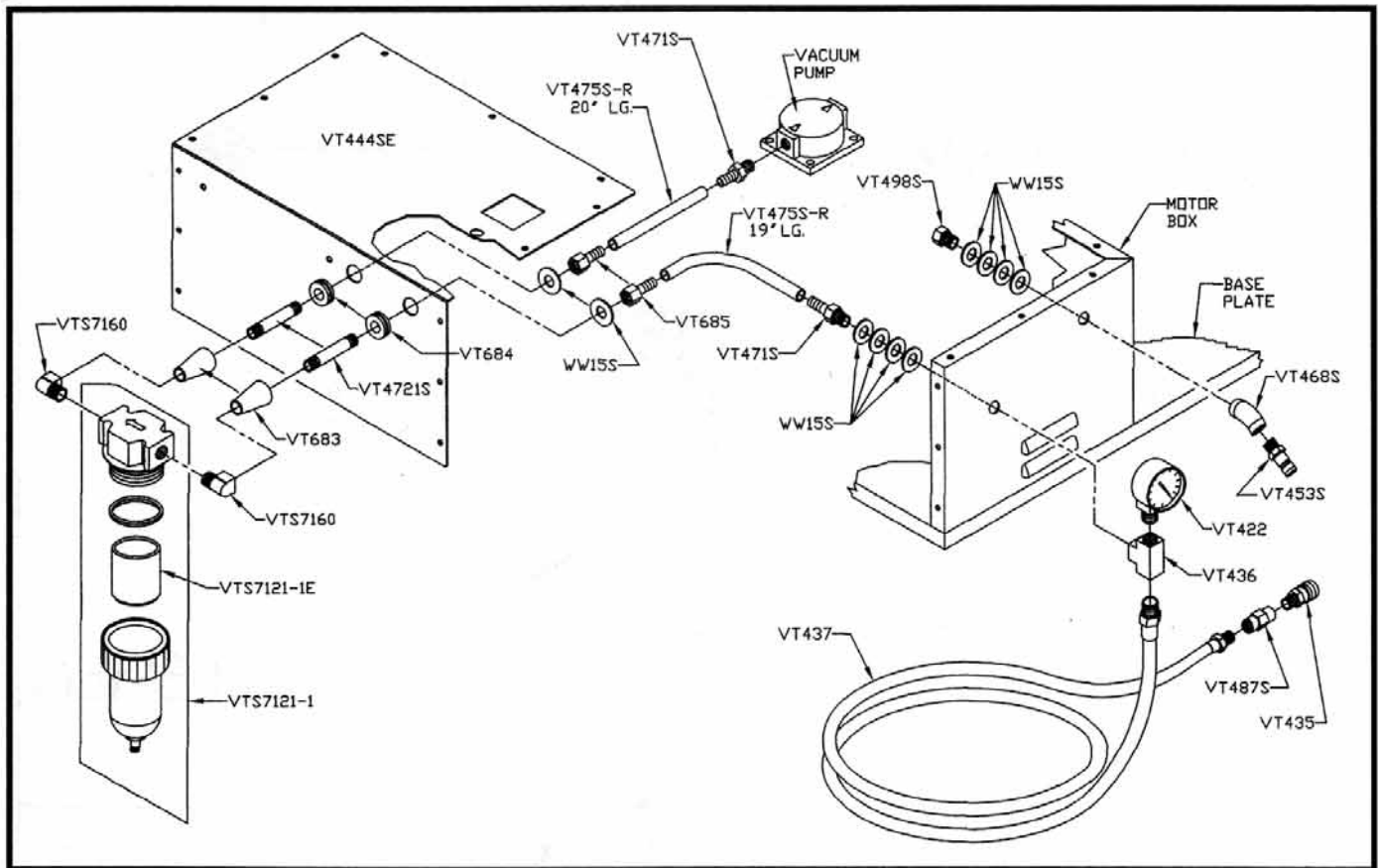

NOTE: ALL PARTS AFTER SERIAL No. 44159

Part No.	Description	Part No.	Description
VT422	Vacuum Guage	VT487S	Coupling $\frac{1}{4}$ FPT \times $\frac{3}{8}$ LG \times $\frac{1}{16}$ W brass
VT435	Coupler $\frac{1}{4}$ MPT, BST-2M	VT498S	Busing $\frac{1}{4}$ MPT \times $\frac{1}{8}$ FPT brass
VT436	Tee, $\frac{1}{4}$ \times $\frac{1}{4}$ \times $\frac{1}{4}$ FPT brass	VT683	Spacer external filter
VT437	Hose 5 ft. Nylonade - $\frac{1}{4}$ MPT w/crimped	VT684	Rubber grommet external filter
VT444SE	Motor & pump cover external filter	VT685	Hose bar $\frac{1}{4}$ FPT \times $\frac{1}{4}$ hose brass
VT453S	Nipple - quick coupler SS	VTS7121-1	External filter
VT468S	Elbow 45 deg. $\frac{1}{4}$ FPT \times $\frac{1}{4}$ FPT SS	VTS7121-1E	Element kit
VT471S	Hose barb $\frac{1}{4}$ \times $\frac{1}{4}$ brass	VTS7121-1K	External filter retrofit kit
VT4721S	Nipple $2\frac{1}{4}$ \times $\frac{1}{4}$ NPT	VTS7160	90 deg. street $\frac{1}{4}$ MPT \times $\frac{1}{4}$ FPT brass
VT475S-R	Hose Nylonade $\frac{1}{4}$ ID \times $\frac{1}{2}$ OD	WW15S	Wrought washer $\frac{3}{16}$ \times $1\frac{1}{4}$ \times $\frac{1}{16}$

VTS7121-1 EXTERNAL FILTER MAINTENANCE



DAILY: Drain all moisture from the filter enclosure. Turn the drain knob counter clockwise to drain.



MONTHLY: The Part No. VTS7121-1E filter element must be replaced once a month for proper vacuum and pump operation. One (1) Part No. VTS7121-1E replacement filters have been included with your machine.

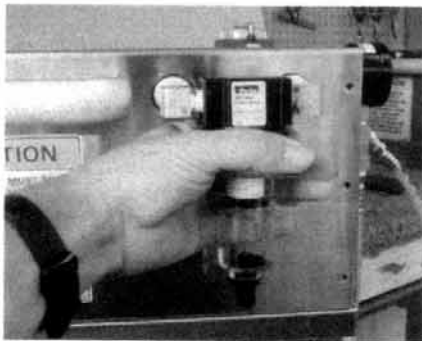

1. Unscrew the bowl lock and remove the bowl.

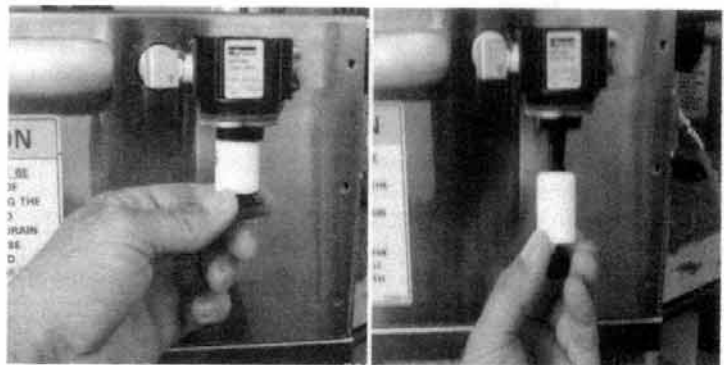

2. Unscrew the filter holder. Lower the filter carefully from the mounting stud. Note the order of the parts.

3. Reassemble the filter in the reverse order. **Taking special care that the sight bowl is fully seated and locked.**

VTS7162 or VTS7162-50 VACUUM PUMP ASSEMBLY

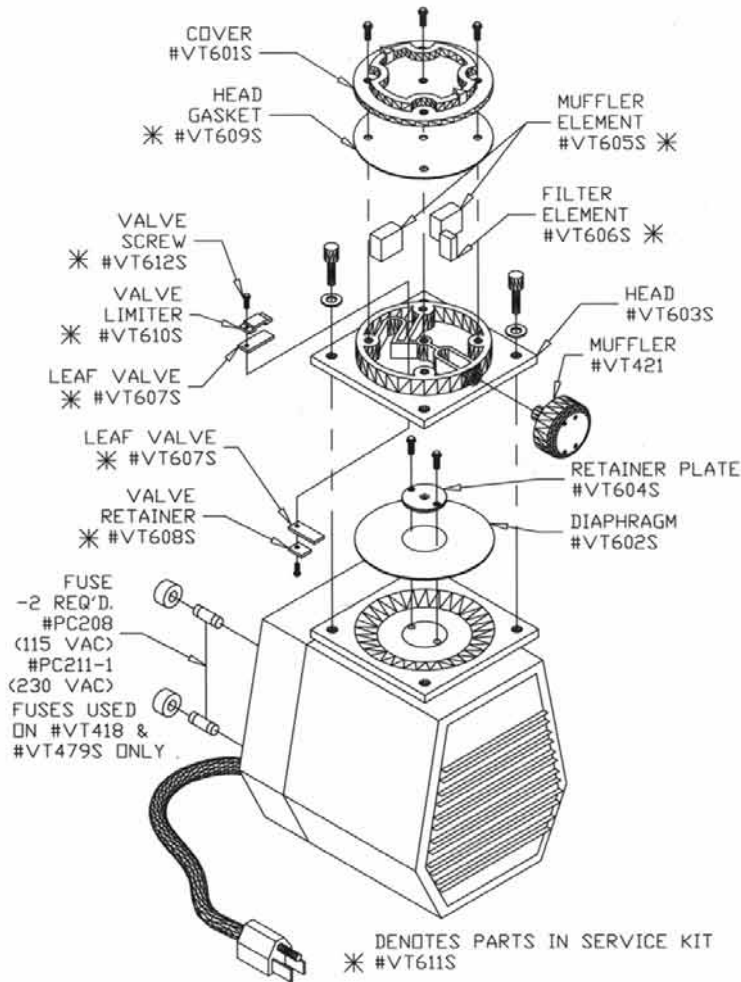

* NO. VT611S DENOTES PARTS IN SERVICE KIT

OPERATING AND MAINTENANCE INSTRUCTIONS

Do not at any time lubricate any of the parts with oil, grease, or petroleum products nor clean with acids, caustics or chlorinated solvents. Be very careful to keep the diaphragm from contacting any petroleum product or hydro carbons. It can affect the service life of the pump.

WARNING: To prevent explosive hazard, Do NOT pump combustible liquids or vapors with these units. Personal Injury and/or Property Damage would result.

To clean or replace the filters and/or rubber gasket, remove the five screws in the top of the unit. The filters and gasket are located beneath this top plate. Remove the filters and wash them in solvent and/or blow off with air and replace. The gasket may be cleaned with water. Replace the filters in proper position and replace the gasket. Note that the gasket and top plate will fit in one position only.

To replace the diaphragm, remove the socket cap screws from the head of the pump. The diaphragm is held in place by two phillips head screws. Remove screws, retainer plate, and the diaphragm. The diaphragm will fit in any position on the connecting rod. Replace the plate and the two phillips head screws. Torque to 30 inch-pounds on DOA and DAA. Torque to 12 inch-pounds on MOA and MAA.

CAUTION: Do not raise any burrs or nicks on the heads of these screws. These burrs could cause damage to the inlet valve.

For replacing the inlet and the outlet valve, remove the slotted machine screw that holds each valve in place. The stainless steel inlet and outlet valves are interchangeable.* Clean them with water. When replacing the outlet valve, place the new valve in location and note there is a retaining bar near the machine screw hole. The retaining bar holds the valve in position. When replacing the inlet valve, note that the valve holder is marked with an X in one corner. This X should be in the lower right hand corner toward the inlet of the air chamber. Replace the head and tighten the socket head screws. to 90-100 inch-pounds of torque on DOA and DAA. Torque to 30 inch-pounds on MOA and MAA. *DOA and DAA models only.

WARNING: The motor may be thermally protected and can automatically restart when the overload resets. Always disconnect power source before servicing. Personal Injury and/or Property Damage could result.

Do not attempt to replace the connecting rod or motor bearings. If after cleaning the unit and/or installing a new Service Kit, the unit still does not operate properly, contact your representative, the factory, or return the pump to one of our authorized Service Centers.

IF YOUR PUMP IS EQUIPPED WITH PLASTIC PLUGS IN THE EXHAUST AND/OR INTAKE PORTS, REMOVE BEFORE STARTING THE UNIT.

VTS-44 WIRING DIAGRAM

IMPORTANT: Always Advise Model & Serial Number
115 VOLTS - 60 HERTZ - 1 PHASE

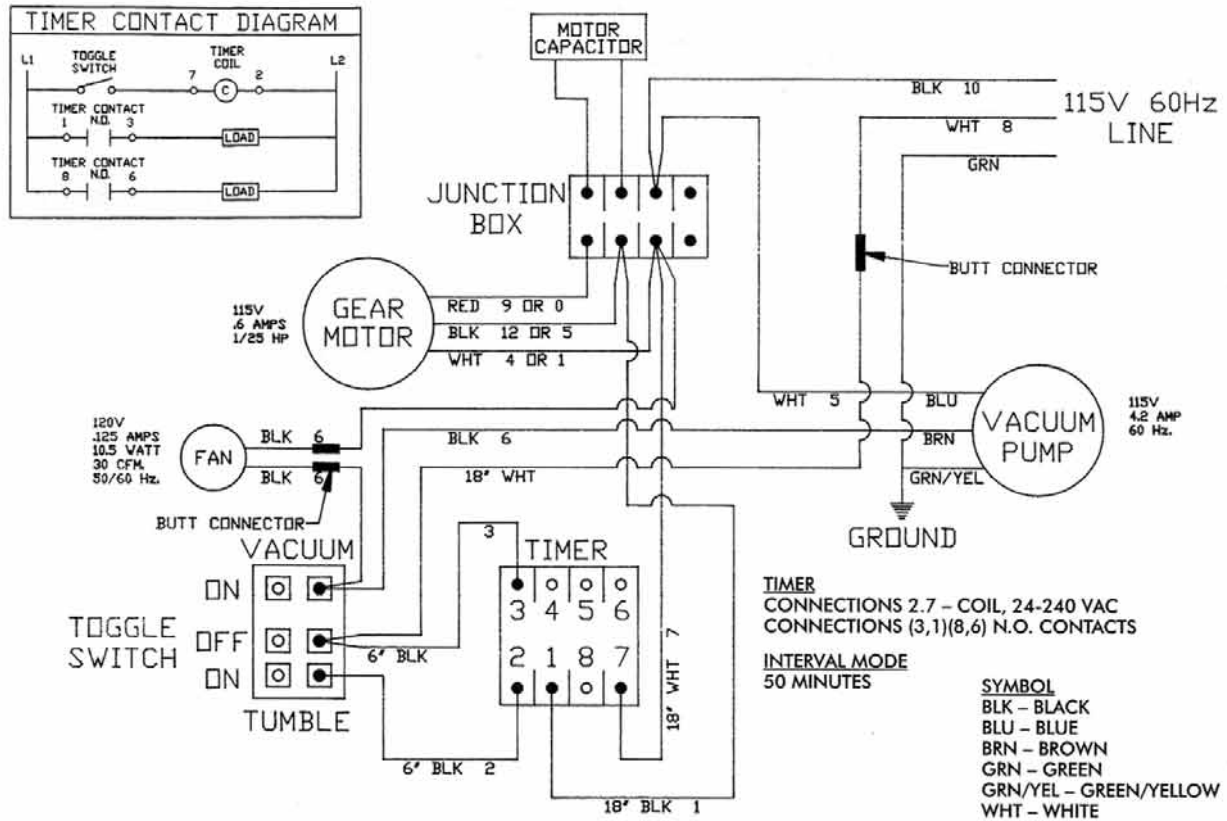

220 VOLTS - 50/60 HERTZ - 1 PHASE

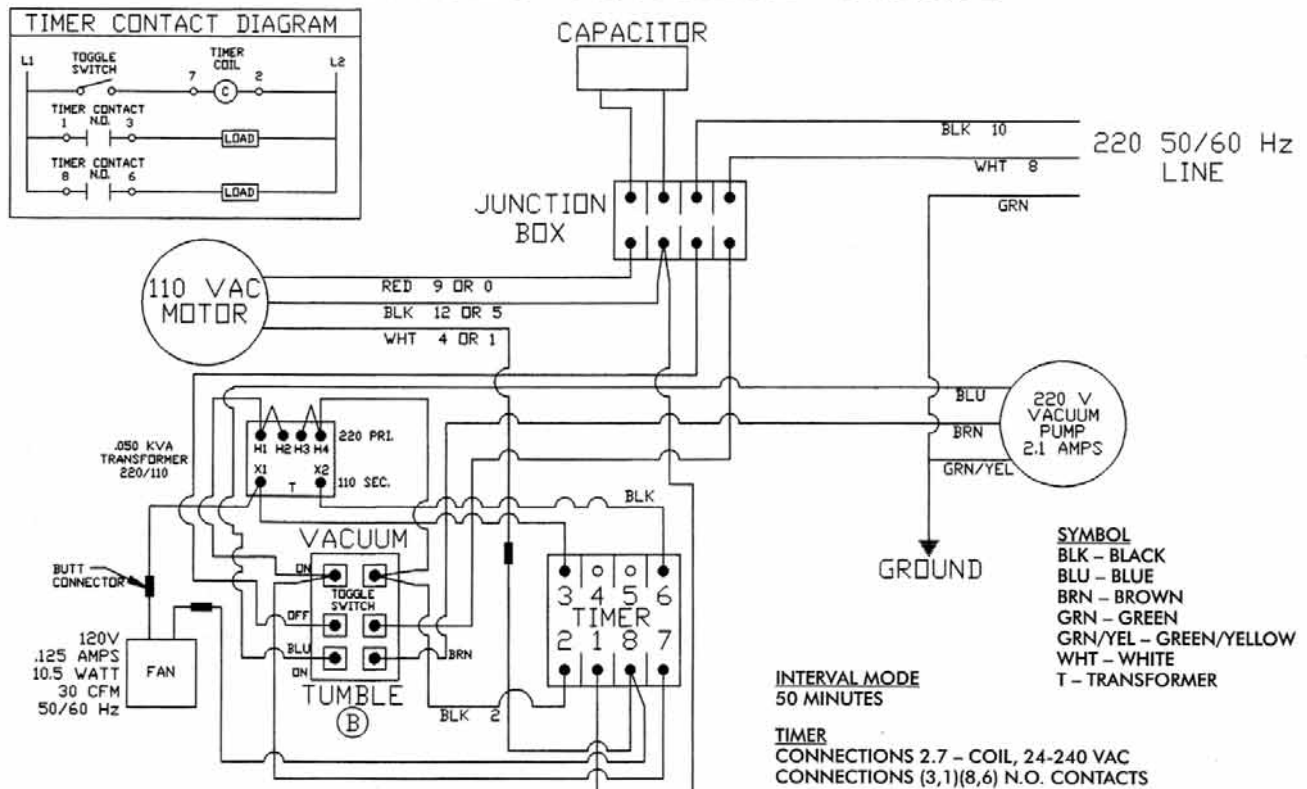

MAINTENANCE



ROTATING DRUM

TO AVOID SERIOUS PERSONAL INJURY

ALWAYS Turn Off, Unplug From Power Source and Perform Lockout/Tagout Procedure to This Machine **BEFORE** Servicing.

NEVER Touch This Machine Without Training and Authorization By Your Supervisor.

NEVER Bypass, Alter, or Modify This Equipment in Any Way From Its Original Condition.

PROMPTLY REPLACE Any Worn or Illegible Labels.

USE ONLY GENUINE BIRO Parts and Accessories Properly Installed.

A. PUMP FILTER

1. Check filter daily. Filter must be drained before the separated moisture and oil reaches the bottom of the lower white element. Drain by unscrewing the black drain plug in bottom of sight bowl.
2. The filter element should be removed and cleaned monthly.
 - a. Unscrew clear threaded bowl.
 - b. Unscrew filter element assembly.
 - c. Clean bowl and filter element. Reassemble filter element. Clean bowl with mild soap and water only. Do not use detergents, cleansing agents, such as acetone, alcohol, benzene or gasoline, which are damaging to plastic.
 - d. Lubricate bowl gasket to assist initial sealing. Use only mineral based oils or grease. Do not use synthetic oils or silicones.
 - e. Screw bowl into body of filter. Close black drain plug.

B. VACUUM PUMP

WARNING: THE MOTOR IS THERMALLY PROTECTED AND CAN AUTOMATICALLY RESTART WHEN THE OVERLOAD RESETS. ALWAYS DISCONNECT FROM POWER SOURCE BEFORE SERVICING. PERSONAL INJURY COULD BE THE RESULT.

1. Do not at any time lubricate any parts of the vacuum pump with oil, grease or petroleum products or clean with acids, caustics or chlorinated solvents. Never allow the diaphragm to contact any petroleum products. This can reduce greatly the service life of the vacuum pump.
2. To clean or replace the internal filters and/or rubber gasket. Remove the five screws in the top of the pump. The filter and gasket are located beneath this top plate. Remove the filters and wash them in solvent and blow off with air or replace. The gasket may be cleaned with water. Replace the filters in proper position and replace the gasket. The gasket and top plate will fit in one position only.
3. To replace the diaphragm, remove the socket cap screws from the head of the pump. The diaphragm is held in place by two phillips head screws. Remove screws, retainer plate and diaphragm. The diaphragm will fit in any position on the connecting rod. Replace the plate and the two phillips head screws. Torque to 30 inch pounds.

CAUTION: DO NOT RAISE ANY BURRS OR NICKS ON THE HEADS OF THESE SCREWS. THESE BURRS COULD CAUSE DAMAGE TO THE INLET VALVE.

CLEANING



ROTATING DRUM TO AVOID SERIOUS PERSONAL INJURY

ALWAYS Turn Off, Unplug From Power Source and Perform Lockout/Tagout Procedure to This Machine **BEFORE** Cleaning or Servicing.

ONLY Use Recommended Cleaning Equipment, Materials and Procedures.

NEVER Spray Water or Other Liquid Substances Directly at Motor, Power Switch or any Other Electrical Components.

ALWAYS Thoroughly Clean Equipment at Least Daily.



DO NOT Use Harsh Chemicals, Scouring Pads or Cleansers. Ordinary Liquid Detergent for Manual Dish or Pot/Pan Washing Will Not Harm the Machine. Harsh Chemicals Will Cause Brown "Rusty" Stains, as will Chlorine Bleach and Similar Products if Allowed to Stand in or on the Machine for any length of time.

CLEANING THE BIRO VACUUM TUMBLER:

1. Turn "OFF", unplug machine from power source, and perform lockout/tagout procedures.
2. The drum, drum lid, baffles in Stainless Steel drum and gasket can be removed and washed in utensil sink. Be sure to flush the vacuum valve with warm soapy water and rinse with clean water thoroughly. The drum, drum lid, baffles from Stainless Steel drum and gasket should be sanitized with an appropriate sanitizer solution approved by your local Health Dept. All parts should be air dried before reassembly and storage.
3. The exterior of the tumbler base can be wiped down with the same type soap solution followed by a rinse water wiping.
4. If food stains are not removed, use a product such as "Bon Ami" or "Soft Scrub". Be sure to wipe with the grain of the Stainless Steel with a soft cloth or sponge.
5. Streaks or water spots can usually be removed with a solution of vinegar and water.

- NOTES -

LIMITED WARRANTY

WARRANTY: The BIRO Manufacturing Company warrants that the BIRO Vacuum Tumbler will be free from defects in material and workmanship under normal use and with recommended service. BIRO will replace defective parts, which are covered by this limited warranty, provided that the defective parts are authorized for return, shipping charges prepaid, to a designated factory for inspection and/or testing.

DURATION OF WARRANTY: The warranty period for all parts covered by this limited warranty is one (1) year from inspection/demonstration advised on returned warranty registration card, or eighteen (18) months from original factory shipping date, whichever occurs first, except as noted below.

PARTS NOT COVERED BY WARRANTY: The following are **not** covered by this limited warranty: VTS7121 and VTS7121-1 vacuum pump inlet filter, VT634S drum lid gasket, and VT454S ball valve on drum lid. This limited warranty does not apply to machines sold as used, rebuilt, modified, or altered from the original construction in which the machine was shipped from the factory. Water contaminated electrical systems and vacuum pump are not covered under this limited warranty. BIRO is not responsible for electrical connection of equipment, adjustments to switch components or any other electrical requirements, which must be performed only by a certified electrician. BIRO is not responsible for service charges or labor required to replace any part covered by this limited warranty or for any damages resulting from misuse, abuse, lack of proper or recommended service.

EXCLUSION OF WARRANTIES AND LIMITATION OF REMEDIES: BIRO gives no warranties other than those expressly stated in this limited warranty. THE IMPLIED WARRANTY OF MERCHANTABILITY, THE IMPLIED WARRANTY OF FITNESS FOR PROCESSING OF FOOD PRODUCTS, AND ALL OTHER IMPLIED WARRANTIES ARE SPECIFICALLY EXCLUDED. BIRO IS NOT LIABLE FOR CONSEQUENTIAL OR INCIDENTAL DAMAGES, EXPENSES, OR LOSSES. THE REMEDIES PROVIDED IN THIS BIRO LIMITED WARRANTY ARE PURCHASER'S SOLE AND EXCLUSIVE REMEDIES AGAINST BIRO.

REGISTRATION CARDS: You must sign, date and complete the warranty registration card supplied with each machine. The warranty registration card must be returned to The Biro Manufacturing Company for proper registration. If no warranty registration card is returned to BIRO, the warranty period will begin from the date the machine was originally shipped from the factory.

HOW TO GET SERVICE:

1. Contact the agency from whom you purchased the machine; or
2. Consult the yellow pages of the phone directory for the nearest authorized dealer; or
3. Contact Biro Mfg. Company for the nearest authorized service entity (250 plus worldwide) in your area.

THE BIRO MANUFACTURING COMPANY

1114 Main Street
Marblehead, Ohio 43440-2099
Ph. 419-798-4451
Fax 419-798-9106
E-mail: service@birosaw.com
Web: <http://www.birosaw.com>