

BIRO®

Our Equipment Works Harder So You Don't Have To

The Biro Model 3334-4003 Meat Saw is the saw of choice for high volume production of retail cuts such as porterhouse steaks and pork chops. Its extra large tables give you plenty of room for heavy production, and the exclusive Biro EZ-Flow front carriage moves easily and smoothly to ease long hours of meat cutting and enhance safety. The 3 hp, (2.2 kW) motor provides all the power you need, and the 4000 feet (1219 meters) per minute cutting speed makes the blade cut through even dense beef bones with ease. The 3334-4003's stainless steel base, cast aluminum head, watertight magnetic switch, and totally enclosed motor stand up to heavy use and frequent washdown, so you get years of productivity out of your saw. Its heavy duty construction, including a tapered roller bearing drive system and stainless steel construction means fewer repairs and lower repair bills, both of which improve your bottom line. Day after day after day, the Biro 3334-4003 Meat Saw works harder so you don't have to.



333455-4003



**Do It Better With
BIRO[®] Meat Saws**

SPECIFICATIONS

MODEL	3334SS-4003
ELECTRICAL	3 HP, (2.2 kW), 220 Volts, 60 Hz, 3 phase; 1 phase and 50 Hz optional (see table below)
ELECTRICAL COMPONENTS	Totally enclosed high humidity motor, watertight magnetic switch system with thermal overload protection
CONSTRUCTION	Heavy duty stainless steel base, legs, and tables with 25% larger front easy flow moving carriage. Cast aluminum head and door structure.
DRIVE SYSTEM	Double V belt and pulleys with tapered roller bearings on drive shafts
BLADE	Hard tooth .022 inch (.5 mm) thick, 3 teeth per inch (8.5 mm between teeth), 5/8 inch (16 mm) wide, 124 inches (3150 mm) long
BLADE SPEED	4000 feet (1219 m) per minute
OPTIONS (Extra cost)	Cord and plug, double flange wheels, lower removable wheels
OPTIONS (No Charge)	Narrow blade guides (.018 inch/.46 mm)
ACCEPTANCE	USDA, UL, NSF, CSA
WEIGHT	470 pounds (214 kg) net 510 pounds (232 kg) gross

MOTORS

HP	TYPE	VOLTS	AMPS	CYCLE	PH	STATUS
3	TE	220/440	8.6/4.3	60	3	STD
3	TE	380/415	4.3	50	3	STD
3	TE	208/230	14.0	60	1	EC
3	TE	220	12.5	50	1	EC
3	TE	550	3.6	60	3	EC

TE = Totally Enclosed STD = Standard EC = Extra Cost

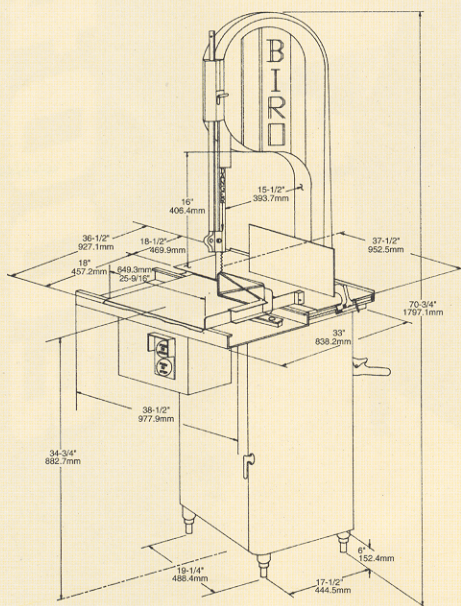

All specifications contained herein are subject to change without notification.

THE BIRO MANUFACTURING COMPANY
1114 WEST MAIN STREET
MARBLEHEAD, OH 43440-2099 U.S.A.
Phone: (419) 798-4451
Fax: (419) 798-9106
<http://www.birosaw.com>
sales-department@birosaw.com

ITEM NO.: LIT 3334-4003-308
 FORM NO.: Md 3334-4003-308-4-01-2-ENG-MARK

Service is available from over 245 locations worldwide