



# **B350Comfort**

**NSF 8-2010**

**SINGLE SPEED AUTOMATIC FEED SLICER**

**INSTALLATION, USE, MAINTENANCE  
& PARTS MANUAL**

MAY 11, 2016



**DECLARATION OF CONFORMITY**  
**A.B.M. COMPANY S.r.l. Via Rho, 6 – 20020 LAINATE MI – Italia**

# Model: B350 COMFORT

s/n: \_\_\_\_\_



Compliant to NSF/ANSI Standard 8: Commercial powered food preparation equipment.

\*EN 60204-1 Machines electrical equipments

\*EN 60335-2-64 Particular requisition for kitchen machines

## *SLICING MACHINES*

# AUTOMATIC VERSION B350 COMFORT

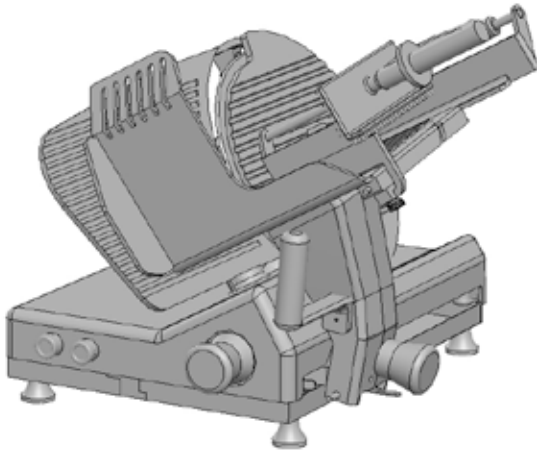

This manual consists of 29 pages as follows:

- Title page with notes for the user;
- Contents, page 3;
- Page 4 to page 28 carrying progressive numeration

# CONTENTS

<b>FOREWORD</b>	<b>4</b>
SCOPE OF THIS MANUAL	4
<b>GENERAL INFORMATION</b>	<b>4</b>
LIMITS OF USE – SAFETY NORMS	4
GENERAL SAFETY REGULATIONS	4
MANUFACTURER'S WARRANTY AND LIABILITY	5
PLATES – CONFORMITY MARKS	5
ENVIRONMENTAL CONDITIONS OF USE	5
<b>PACKING</b>	<b>6</b>
OPENING THE BOX	6
<b>TECHNICAL DESCRIPTION AND PROPOSED CONDITIONS OF USE</b>	<b>7</b>
GENERAL DESCRIPTION	7
MECHANICAL AND ELECTRICAL SAFETY DEVICES	7
WARNING: RESIDUAL RISKS	7
DIMENSIONS MAIN TECHNICAL DATA	8
MAIN COMPONENTS	9
<b>MACHINE COMMISSIONING AND FUNCTION TESTS</b>	<b>10</b>
INSTALLING THE MACHINE	10
ELECTRICAL CONNECTION	10
MANUAL USE	10
AUTOMATIC USE	10
<b>USING THE MACHINE</b>	<b>12</b>
LOADING THE PRODUCT ON THE TRAY AND SLICING	12
<b>CLEANING THE SLICER</b>	<b>15</b>
GENERAL	15
DISASSEMBLING THE MACHINE FOR CLEANING	15
DESASSEMBLING THE GUIDE BAR FOR CLEANING	18
CLEANING THE SLICER UNDERNEATH - LIFTING DEVICE	19
CLEANING AND SANITIZING THE BLADE	20
REASSEMBLING THE MACHINE	21
BLADE SHARPENING	22
LUBRICATION	26
<b>DISMANTLING THE SLICER</b>	<b>27</b>
RECOMMENDED SPARE PARTS	28

## **FOREWORD**

### **SCOPE OF THIS MANUAL**

This manual contains all the necessary information to install, use and service the gravity slicers for food (please see models in paragraph “Technical Description”). The scope of this document, hereinafter the “manual”, is to permit users, and especially end users, to take all the cautions and provisions possible for using this machine safely and for a long time.

### **GENERAL SAFETY REGULATIONS**

The slicers must only be used by, suitably trained personnel. Furthermore, they must have read this manual carefully.

#### **In particular, please comply to the following instructions**

- Install the machine according to the instructions contained in the “Installation” section.
- Do not remove the transparent protections, do not modify nor exclude the mechanical and electrical safety devices.
- Do not use the machine with improvised connections, or provisional or non - insulated cables.
- Check the power cable on the machine body regularly, and when necessary have them replaced by a qualified personnel.
- In case of abnormalities, defective operation, incorrect movement, unusual noise, etc stop the machine immediately.
- Before cleaning or servicing, disconnect the machine from the mains.
- Always use scratch proof and non-slip gloves during cleaning or maintenance.
- Lay or remove the goods to be sliced on the sliding plate only when the latter is completely pushed back and the thickness control knob is positioned to 0.
- To move the carriage tray when slicing, use the handle or the product grip handle.
- For extraordinary maintenance (to replace the sharpener wheels, the blade, or others) please contact the manufacturer or qualified and duly authorized personnel.
- Avoid running the slicers with no product on it
- The slicers are equipped with a ventilated motor
- **WARRANTY: 1 YEAR** except for the electrical parts

## MANUFACTURER'S WARRANTY AND LIABILITY

The manufacturer's warranty covering the functioning of the machines and their compliance to the service for which they have been designed depends on the correct application of the instructions contained in this manual.

***The Manufacturer assumes no liability either direct or indirect deriving from:***

- Failure to comply with the instructions contained in this manual;
- Use of the machine by personnel who has not read or fully understood the content of this manual
- Use not complying to the specific norms currently applicable in the country of installation
- Unauthorized modifications and/or repairs
- Use of non original accessories or spare parts.
- Exceptional events.

## PLATES – CONFORMITY MARKS

The machine has been constructed in compliance with NSF/ANSI Standard 8. All the parts used in the machine meet the terms of NSF/ANSI compliance and the NSF mark has been applied to substantiate this compliance.

The plate carrying the Manufacturer's data, the machine data and the NSF mark are applied onto the machine base under the blade guard tie-rod knob.

***In case of wear or damage, the user must replace it.***



## ENVIRONMENTAL CONDITIONS OF USE

- Temperature from -5 °C to + 40 °C
- Relative humidity max 95%

## PACKING

### OPENING THE BOX

On receipt, check packaging integrity, otherwise inform the forwarding agent or the area agent immediately.

To unpack the machine, proceed as follows:

- Open the box and remove your copy of the manual of use and maintenance, then proceed according to the instructions found in that manual;
- Lift the machine still wrapped in a transparent polyethylene sheet and extract it from the box
- Now check the box contents and make sure it corresponds to what is shown on the external label.

### WARNING:

The packaging components (cardboard, polyethylene, and others) are classified as normal solid urban waste and can therefore be disposed of without difficulty. In any case, for suitable recycling, we suggest disposing of the products separately (differentiated waste) according to the current norms.

**DO NOT DISCARD ANY PACKAGING MATERIALS IN THE ENVIRONMENT!**



## **TECHNICAL DESCRIPTION AND PROPOSED CONDITIONS OF USE**

### **GENERAL DESCRIPTION**

The machine is essentially made of a base supporting a circular blade mounted in tilted position. This blade is driven by an electrical motor to slice food. The machine is equipped with a carriage holding a product tray and sliding on tracks mounted under the base top, parallel to the blade.

Slice thickness is adjusted by means of a gauge plate mounted in front of the blade. This plate, against which rests the product to be sliced is moved transversally with respect to the blade by a value corresponding to the desired slice thickness. The product is fed to the machine (towards the gauge plate) by gravity.

All the machine components are made of polished and anodized oxidized aluminum alloy, of stainless steel and food grade plastic material.

The blade is driven by an electrical motor, transmission is by means of a longitudinally grooved belt.

The machine is started and stopped by a control button provided with auxiliary circuit preventing accidental restarts after an outage.

Some of the machine models have a user-friendly and safe built-in blade sharpener.

### **MECHANICAL AND ELECTRICAL SAFETY DEVICES**

**The following mechanical safety devices were installed:**

- A series of aluminum guards on the product carriage.

**The following electrical safety devices were installed:**

- Start/stop button system requiring a voluntary restart of the machine in the case of an outage or interruption of the power supply.

### **PRODUCTS THAT CAN BE SLICED**

- All types of cold cuts (raw, cooked, smoked);
- Meat without bone (raw or cooked, at a temperature not less than + 3 °C;
- Cheese cuts (obviously types that can be sliced such as gruyere, fontina, etc.).

### **PRODUCTS THAT MUST NOT BE SLICED:**

- Frozen or deep-frozen food
- Food containing bones (meat or fish)
- Any other non-food product



#### **WARNING: RESIDUAL RISKS**

**Not with standing all the possible cautions taken during the design and the construction of the machine, residual risks (cutting) still exist during use or during cleaning or maintenance. Therefore be careful and PAY THE UTMOST ATTENTION to what you are doing.**

**DO NOT use the machine if you are not in perfect psychological and physical conditions. DO NOT ALLOW anyone near the machine when it is in use. ALWAYS wear gloves that can resist cuts or tears when cleaning, lubricating or sharpening the blade.**

**Slice only the products mentioned as sliceable. NEVER try to slice products that have been mentioned as non sliceable.**





## DIMENSIONS MAIN TECHNICAL DATA

### AUTOMATIC GRAVITY SLICERS

MODEL	UNI 350 COMFORT		MODEL
motor Kw	0,30		motor Kw
blade diam	14"	350	blade diam
rpm	200		rpm
slice thickness	0 - 1"	0 - 25	slice thickness
max cut $\emptyset$	9"1/4	235	max cut mm $\emptyset$
max cut $\square$	11"13/16x6"7/64	300x155	max cut mm $\square$
max cut $\square$	7"7/8x7"7/8	200x200	max cut $\square$
<b>Cutting Speed</b>			
Speed	40		
<b>Overall dimensions</b>			<b>Overall dimensions - mm</b>
length	17"23/32	450	length
width	23"7/32	590	width
height	22"3/4	578	height
gross weight - Lbs	132 Lbs	60	gross weight - Kg
net weight - Lbs	121 Lbs	55	net weight - Kg
box dimensions	28"x32"43/64x 33"15/32	710x830x850	box dimensions mm

## MAIN COMPONENTS gravity version

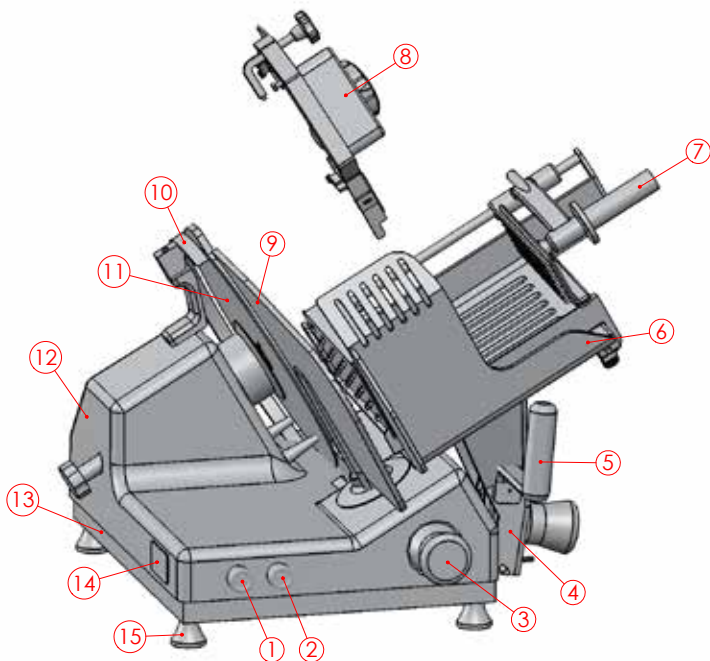

CODE	DESCRIPTION
1	DOUBLE START SWITCH
2	STOP SWITCH
3	THICKNESS KNOB
4	CARRIAGE SUPPORT
5	CARRIAGE HANDLE
6	CARRIAGE
7	PUSHER HANDLE
8	SHARPENER
9	GAUGE PLATE
10	BLADE GUARD
11	BLADE
12	FRAME
13	TRANSMISSION COVER
14	MANUFACTURER IDENTIFICATION PLATE
	MACHINE DATA AND UE MARKS
15	SUPPORT FOOT

# MACHINE COMMISSIONING AND FUNCTION TESTS

## INSTALLING THE MACHINE

Position the machine on a well leveled, smooth and dry top suitably dimensioned to withstand the machine weight.

## ELECTRICAL CONNECTION

Install the machine near a compliant outlet derived from a system meeting the current norms.

**The user is responsible for** ascertaining that the electrical system is suitably dimensioned and functions correctly (supply line, outlet, distribution panel, differential protecting breaker, grounding).

**Before carrying out the connection** ascertain that the mains characteristics correspond to those indicated on the machine plate.

## MANUAL USE

### START AND STOP BUTTONS

- Press the green button (1) to start running the blade.
- The light turns on to indicate that the machine works correctly.
- Press the red button to stop the blade (2).

**Slice thickness** can be adjusted by turning the graduated knob (4) anti clockwise.

**Thickness adjustment range:** see paragraph "Technical description and conditions of use".

## AUTOMATIC USE

### START AND STOP BUTTONS

- Lift and pull the lever (3) (A + B) to engage the automatic movement.
- Press the green button (1) to start running the blade.
- Press another green button (1) to start the carriage movement.
- The light turns on to indicate that the machine works correctly.
- Press the red button to stop the blade and carriage (2).

**Slice thickness** can be adjusted by turning the graduated knob (4) anti clockwise.

**Thickness adjustment range:** see paragraph "Technical description and conditions of use".

## FUNCTIONING TEST AND BLADE ROTATION DIRECTION

Start the machine and check whether the light is on; make sure that the blade rotates in the direction indicated by the arrow (anti clockwise if you look at the machine from the blade plate side).

- Ascertain that the carriage and the pusher slide correctly;
- Ascertain that the gauge plate works and adjust thickness to desired value.

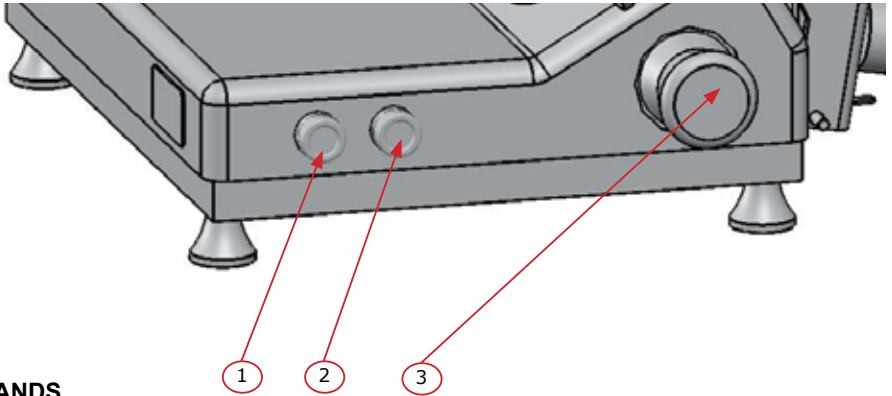

**COMMANDS**

**START AND STOP BUTTONS**

- Green button (1): first push to start running the blade (green light).  
second push to start running the carriage (blue light).
  - The light turns on to indicate that the machine works correctly.
  - Press the red button to stop the machine completely (2)
- Slice thickness** can be adjusted by turning the graduated knob (3) anti clockwise.

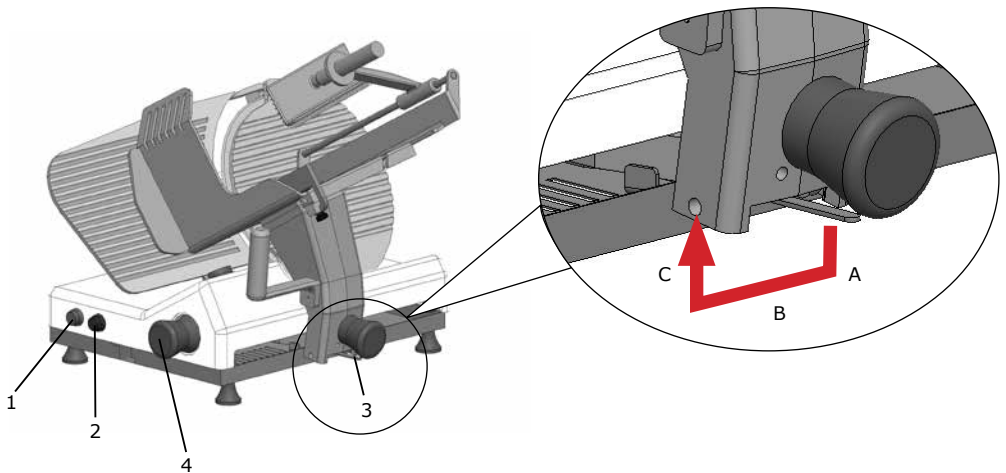

**TO ACTIVATE THE AUTOMATIC SLICING ACTION** push down the lever (A) and then pull right to the stopping position (B), automatically will lift up (C).  
Once the lever is in "the activately position", drive the meat plate handle forwards and backwards since when locking the auto mechanism.

**WARNING:**  **The machine must always be switched off before proceeding with the above operations!!**

## USING THE MACHINE

### LOADING THE PRODUCT ON THE TRAY AND SLICING

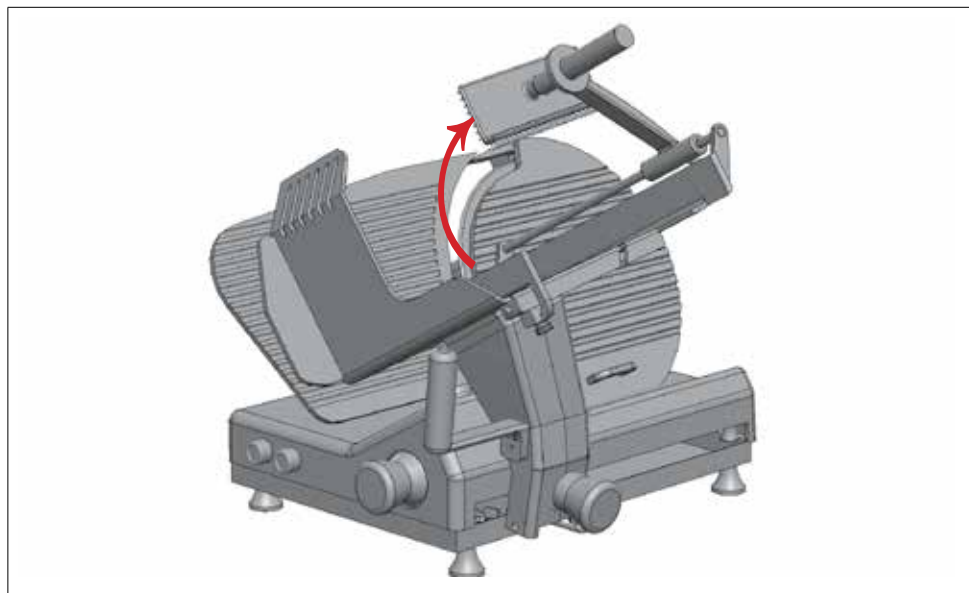

Lift the gripper arm

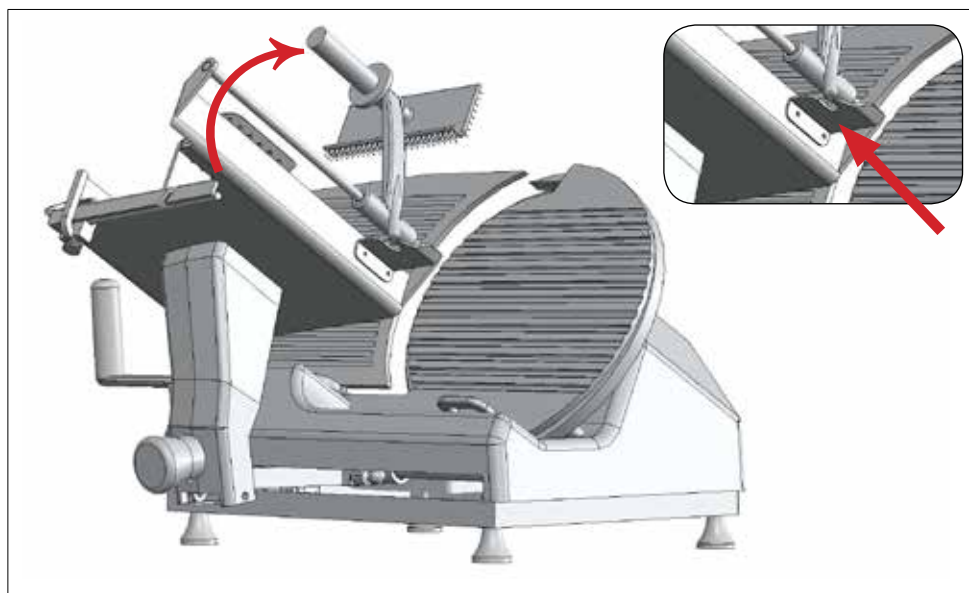

Lock the gripper arm into the rest position as shown in photo B

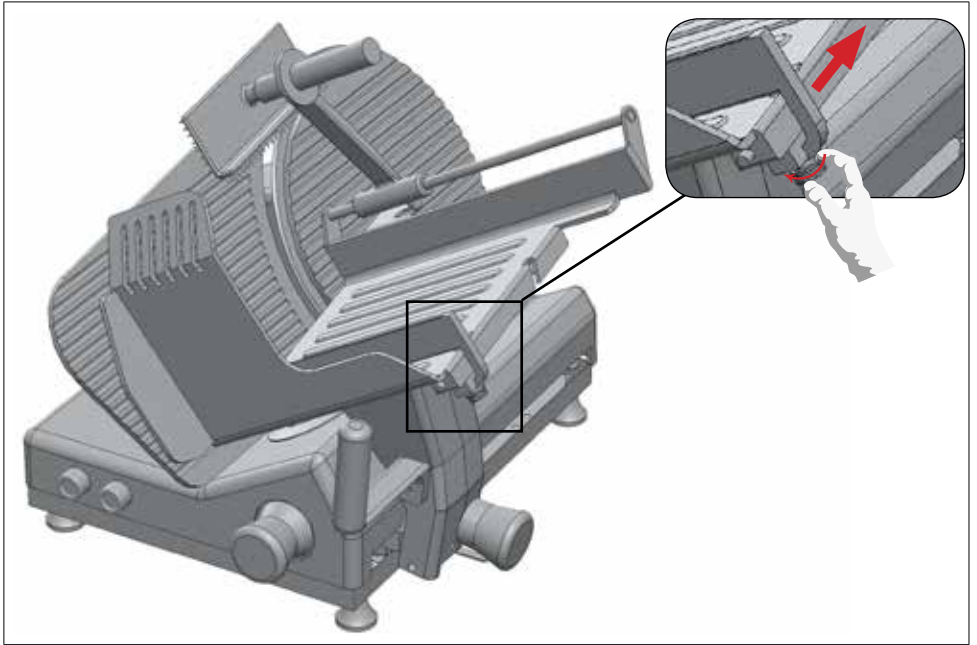

Unscrew the fence retaining knob and slide the fence in to the outer position

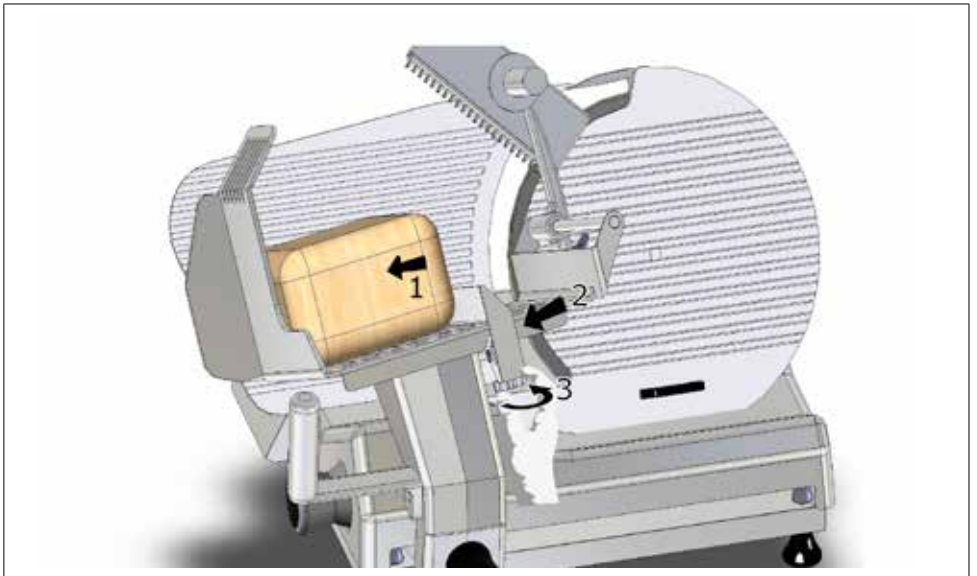

1. Load the product on to the meat platform
2. Slide the fence against the product
3. Lock the fence in place firmly using the locking knob

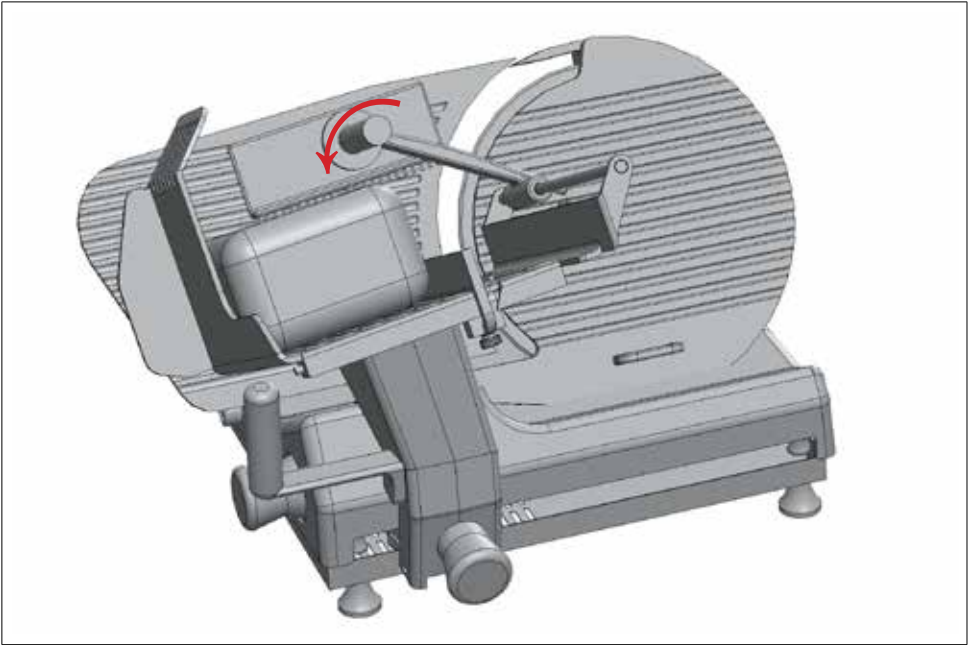

Locate the gripper arm onto the product

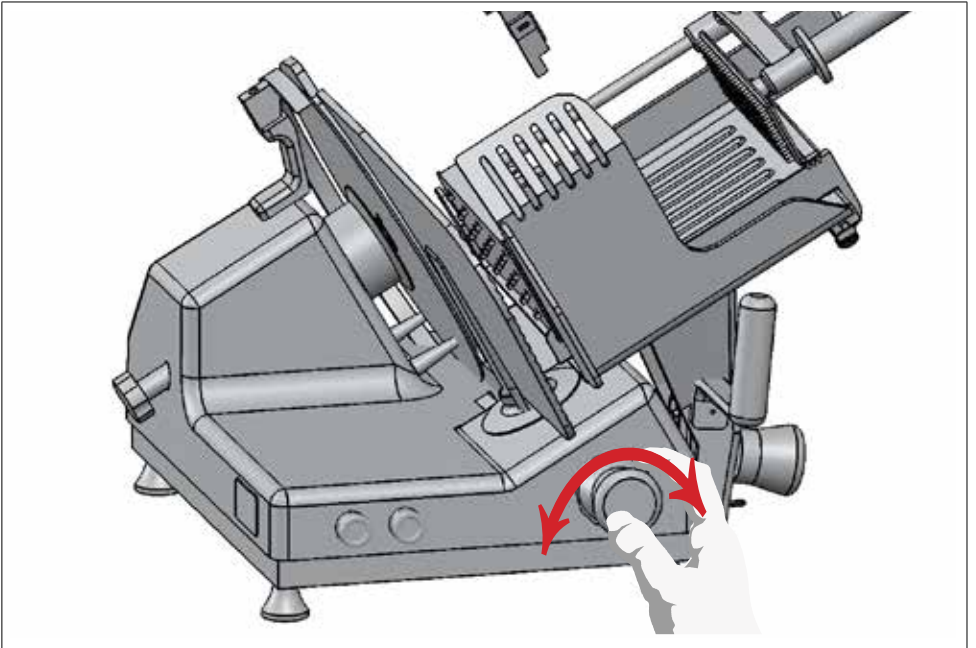

Select the thickness of the product to be sliced using the portion thickness control knob

## CLEANING THE SLICER

### GENERAL

The machine must always be accurately cleaned at least once a day, and more often if necessary.

Always use protective gloves.

### DISASSEMBLING THE MACHINE FOR CLEANING

- Disconnect the plug from the mains;
- Turn the gauge plate to '0';
- Remove the various components as described in the following paragraphs:
- Unscrew (anticlockwise) the blade guard rod (ref. 1);
- Remove the blade guard using for this operation only cover handle (ref. 2).
- Remove the slice guard.

To clean the machine body and the blade use only a cloth dampened with water and biodegradable lathery detergent having 7-8 pH and at a temperature not below + 30°C.

**Do not clean the machine by using jets of water or vapor or similar systems.**

#### WARNING:



Use scratch-proof and non-slip gloves to carry out the following operations.  
Proceed carefully and pay attention to what you are doing.  
Danger of cutting!

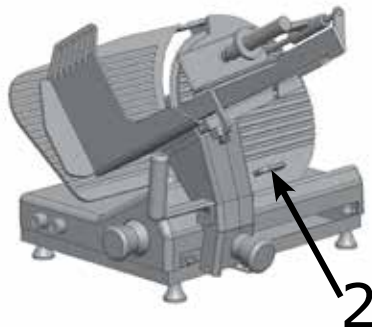
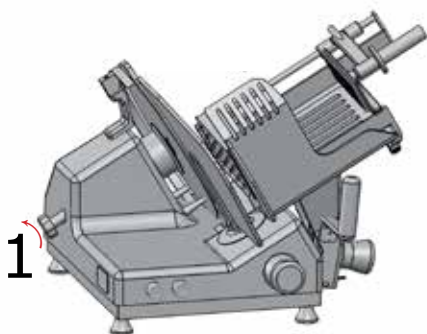



- Stop the machine, rotate the adjustable knob to regulate the gauge plate and position it on 0 (1)
- Return the carriage to the operators side (2)
- Turn the knob (3) anti clockwise, until loose, the carriage will then drop back for cleaning (4).

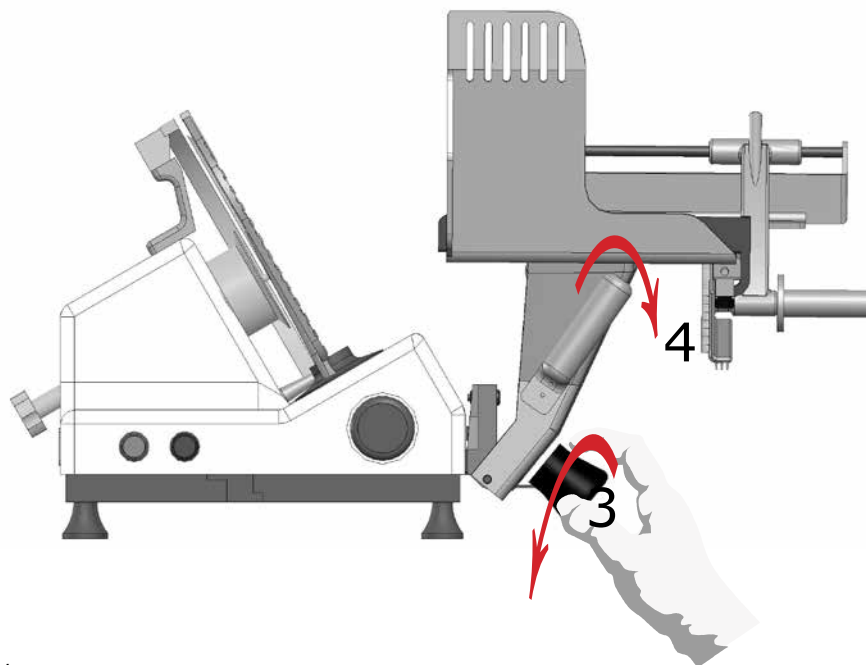
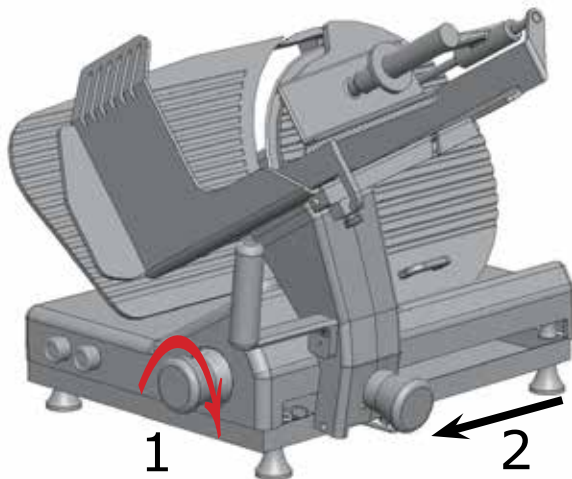

**UNSCREW THE BLADEGUARD ROAD (1), than remove the cover blade (2)**

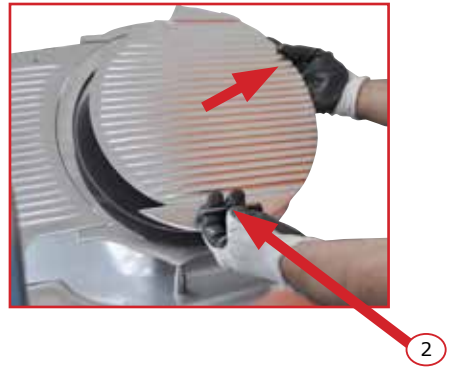

Carefully insert the doth between the knife and the knife ring guard. While holding the cloth between the knife and the ring guard, work it along the entire backside of the knife. Repeat this procedure as necessary . A nylon brush could also be used.

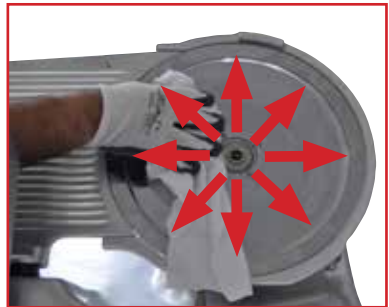

Carefully wash the top and bottom of the knife by wiping from the center of the knife outward.



**REASSEMBLE THE SLICER: PROCEED AS INDICATED FOR THE PREVIOUS OPERATIONS BUT IN REVERSE ORDER**

## DESASSEMBLING THE GUIDE BAR FOR CLEANING



1. Unscrew the knob

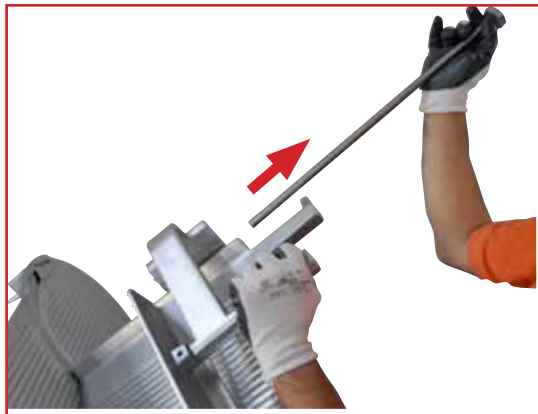

2. Remove the bar



3. Removable parts ready for cleaning



**REASSEMBLE THE SLICER: PROCEED AS INDICATED FOR THE PREVIOUS OPERATIONS BUT IN REVERSE ORDER**

## CLEANING THE SLICER UNDERNEATH - LIFTING DEVICE



1. Move the carriage forward



2. Lift the machine by using the proper lever



3. Clean underneath

**LIFT DOWN THE MACHINE BY USING THE PROPER LEVER**

## CLEANING AND SANITIZING THE BLADE

- Disconnect the plug from the mains;
- Turn the gauge plate to '0';

To clean the machine body and the blade use only a cloth dampened with water and biodegradable lathery detergent having 7-8 pH and at a temperature not below + 86°F.

### WARNING:



Use scratch-proof and non-slip gloves to carry out the following operations. Proceed carefully and pay attention to what you are doing. Danger of cutting!

### SANITIZING

To prevent illness or death caused by the spread of food-borne pathogens, it is important to properly clean and sanitize the entire slicer as any surface of the slicer can become contaminated. It is the responsibility of the slicer owner/operator to follow all guidelines, instructions and laws as established by your local and state health departments and the manufacturers of chemical sanitizers.



Once your slicer makes contact with food product, the entire slicer, including removable parts, must be thoroughly cleaned and sanitized. This process is to be repeated at least every 4 hours using these procedures and information; and comply with additional laws from your state and local health departments.



As with all food contact surfaces, it is extremely important to properly sanitize the entire slicer and to closely follow the instructions on your quaternary sanitizer container to ensure proper sanitation is achieved to kill potentially harmful bacteria.

**IMPORTANT:** If a chemical sanitizer other than chlorine, iodine or quaternary ammonium is used, it shall be applied in accordance with the EPA-registered label use instructions. Excessive amounts of sanitizer and/or use of products not formulated for stainless steel or aluminum may VOID your warranty.

Sanitizer concentration shall comply with section 4-501.114, Manual and Mechanical Warewashing Equipment, Chemical Sanitization - Temperature, pH, Concentration, and Hardness of the FDA Food Code.

Maintain the Owner's Manual supplied with this machine and refer to it often for complete information on cleaning, sanitizing and maintaining the slicer.

**ALWAYS SANITIZE YOUR MACHINE COVERING ALL THE MACHINE WITH THE PROPER PRODUCT.**

## REASSEMBLING THE MACHINE

Proceed as indicated for the previous operations but in reverse order.

The operator is allowed to perform the following maintenance operations:

- Blade sharpening: regularly (intervals and duration obviously depend on the use of the machine, time of use and type of product sliced);
- Lubrication of carriage sliding guides: once a week.
- Lubrication of product grip sliding bar: once a week.
- Checking the power supply wire conditions and the gland plate: from time to time.

### **WARNING**

**Maintenance must always be carried out when the machine is disconnected from the mains.**

**Always make sure that the adjustable knob is in the “O” position**

The following maintenance operations are to be entrusted only to **personnel authorized by the manufacturer**:

- Replacing the blade;
- Replacing the sharpener stones;
- Replacing the motor transmission belt;
- Replacing electrical system components under the machine base;
- Repairing structural parts, repairing the components under the base.

## INSPECTING THE SLICER FOR DAMAGED OR BROKEN PARTS INCLUDING GASKETS & SEALS



A thorough visual inspection should be made of the entire slicer and its parts.

Biro urges the owner / operator to inspect all components often, including ones that are the detachable for cleaning and sanitizing. This inspection should include: looking for damaged parts, broken seals or gaskets, and areas that may be more difficult to clean and sanitize.



**WARNING:** IF A SEAL OR GASKET IS FOUND TO NOT PROPERLY SEAL, IS DAMAGED, OR IS MISSING, THE SLICER MUST BE REMOVED FROM SERVICE UNTIL IT IS REPAIRED BY AN AUTHORIZED SERVICER

The recommended interval between inspections shall not exceed six months for components that are detached for cleaning and sanitizing and twelve months for all others.

Authorized sales must provide to inspect the machine every 6 months.

## BLADE SHARPENING - Versions with NOT INTEGRATED sharpener

Before proceeding, carefully clean the machine as explained in the previous paragraphs:



Sharpening can be done only up 0,5 inches of the blade diameter value.

Beyond this value, the **BLADE MUST BE REPLACED ONLY** by personnel **AUTHORIZED BY THE MANUFACTURER**.

To sharpen the blade periodically, proceed as per the following instructions:



1) Clean the blade

---



2) Assure the sharpener is at zero position

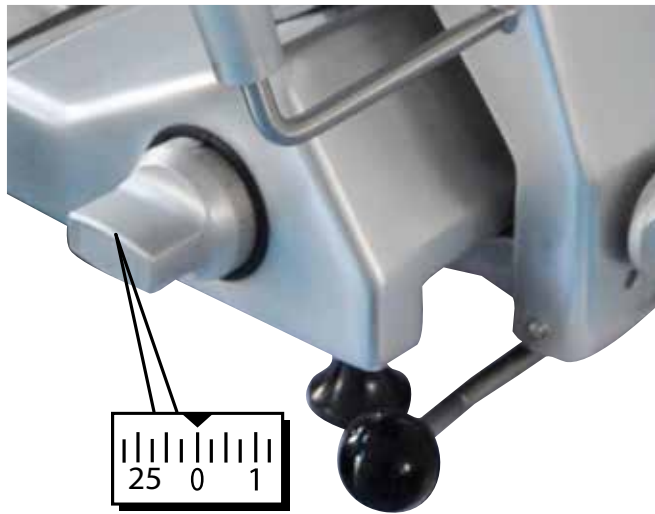

3) Move thickness regulator to the 25 mm position.  
This opens the blade to the desired position ready for positioning the sharpener.

---



4) Meat plate positioned in the middle.





5) The small recess on the gauge plate is for the positioning of the sharpening mechanism  
Verify the correct position

---

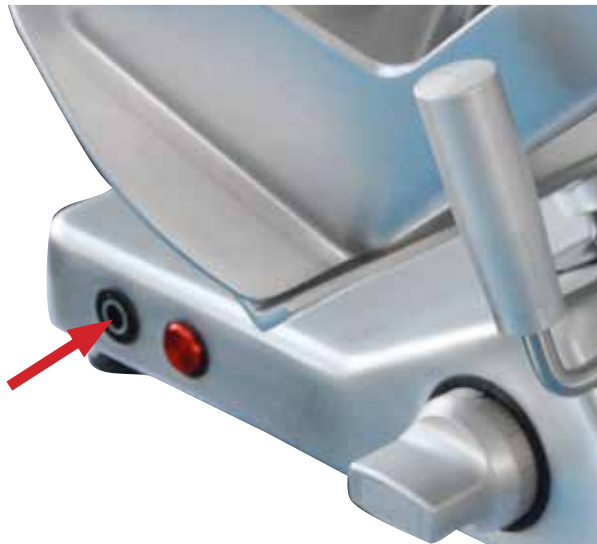

6) Start blade rotating



7) Turn dial to position 1. This will sharpen the rear of the blade. Run for 20", turn dial to position 2 for 5". This will take the burr of the front surface of the blade.

---

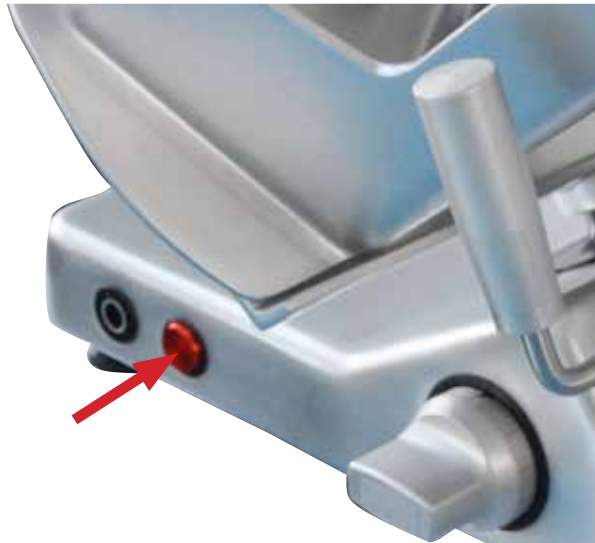

6) Stop the machine.  
Remove the sharpener and **SANITIZE** the blade before using the machine again.



**BIRO 350GCO  
Recommended Spare Parts  
2016 EDITION**



**Z9MAF  
Sharpening stone**



**B350 GCO :  
AF01US  
Sharpener**

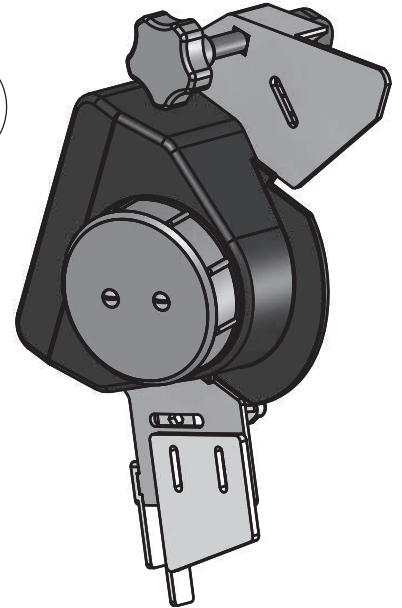

**Z9MSB  
Cleaning stone**



**G111-A  
Water-ring protection**

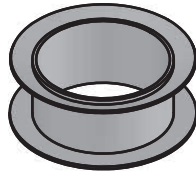

**G8CIN  
Transmission Belt**



**Z9PIE  
Foot**

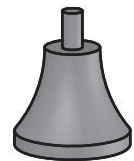

**Z14AMR  
Single phase card 115V-60Hz**

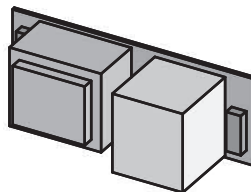

**Z13AMR  
Single phase card 220V-50Hz**

**MODEL 350 3rd GEN. :  
Z5L3G  
Blade**

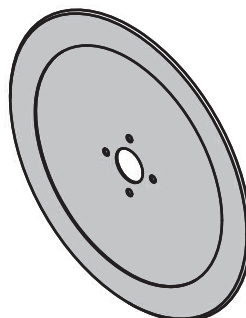



**BIRO  
B 350 GCO  
AUTOMATIC SLICER**



**STANDARD 8 - 2010**

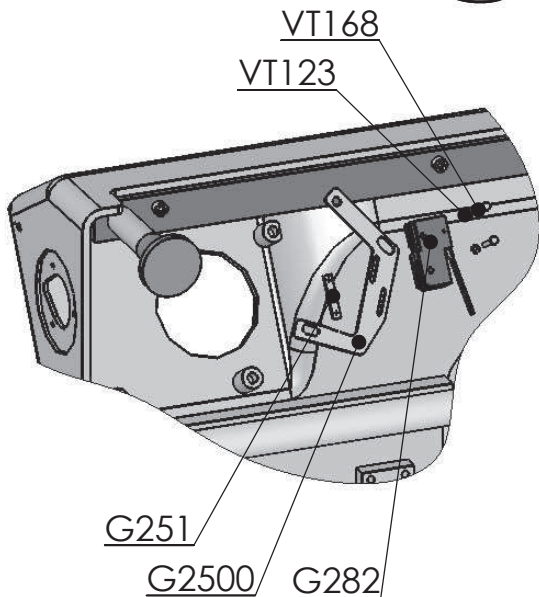
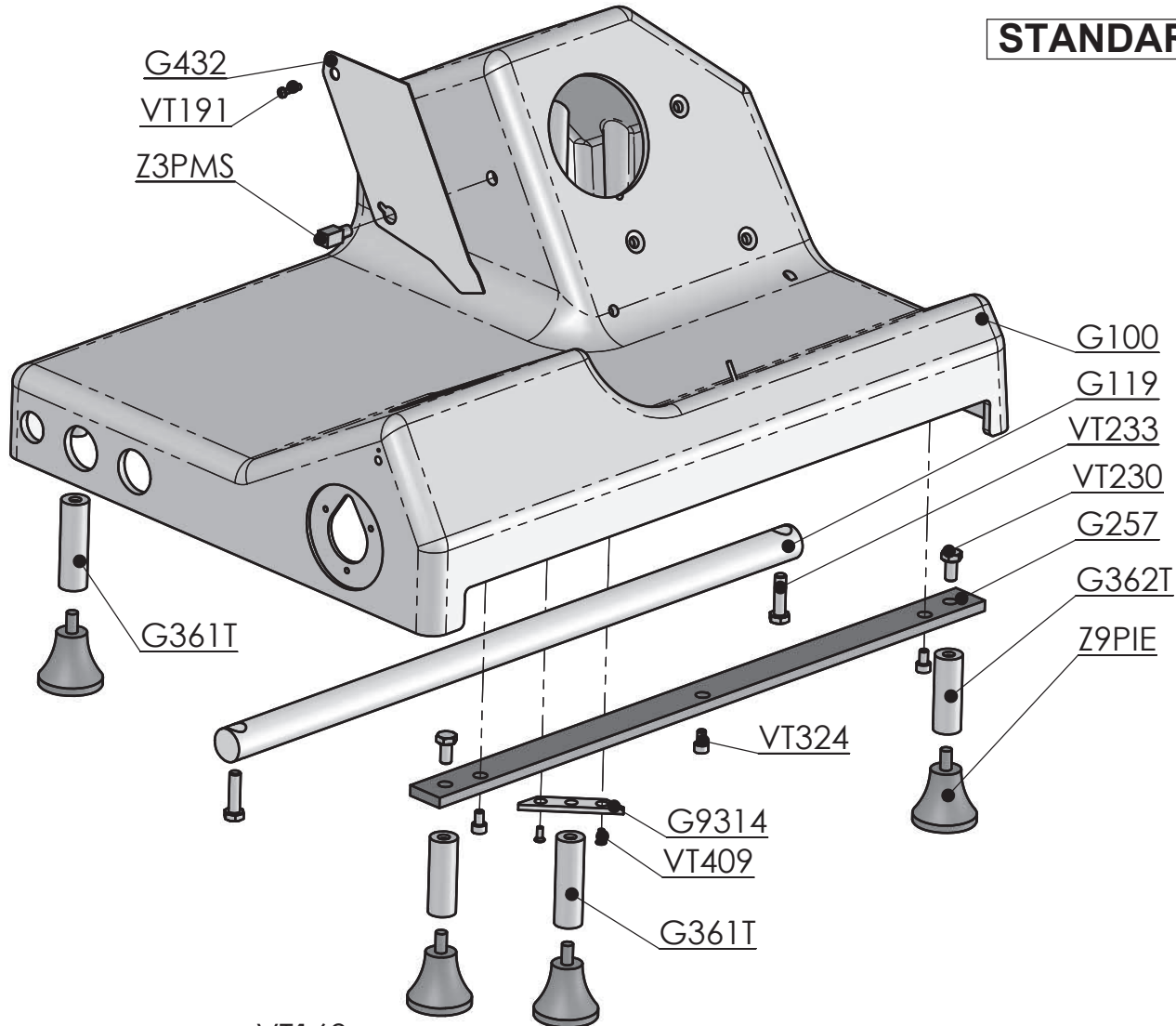

CODE	DESCRIPTION
G100	FRAME
G119	SLIDE ROD - 25 x 578
G2500	BRACKET - SWITCH
G251	BRACKET - OPENED GAUGE PLATE SW
G257	SS BAR - TRANSPORT ROLLER
G282	MICRO SW AUT. STOP GO D2W 20845
G361T	SS FOOT SPACER 20 x 96 M8
G362T	SS FOOT SPACER 20 x 124 M8
G432	SLICE SEPARATOR OR
G9314	FOOT PLATE
VT 123	FLAT WASHER M3 SS
VT 168	HEX HEAD SCREW M3-0.5x16 SS
VT 191	HEX HEAD SCREW M5-0.8x8 SS
VT 230	HEX HEAD SCREW M8-1.25x16 SS
VT 233	HEX HEAD SCREW M8-1.25x30 SS
VT 324	HEX SOCKET HEAD SCREW M6-1.0x10 SS
VT 409	CYLINDRICAL FLAT HEAD FOR SCREW DRIVER M5-0.8x12 SS
Z3PMS	SCRAPER KNOB
Z9PIE	FOOT



# BIRO B 350 GCO AUTOMATIC SLICER



**STANDARD 8 - 2010**

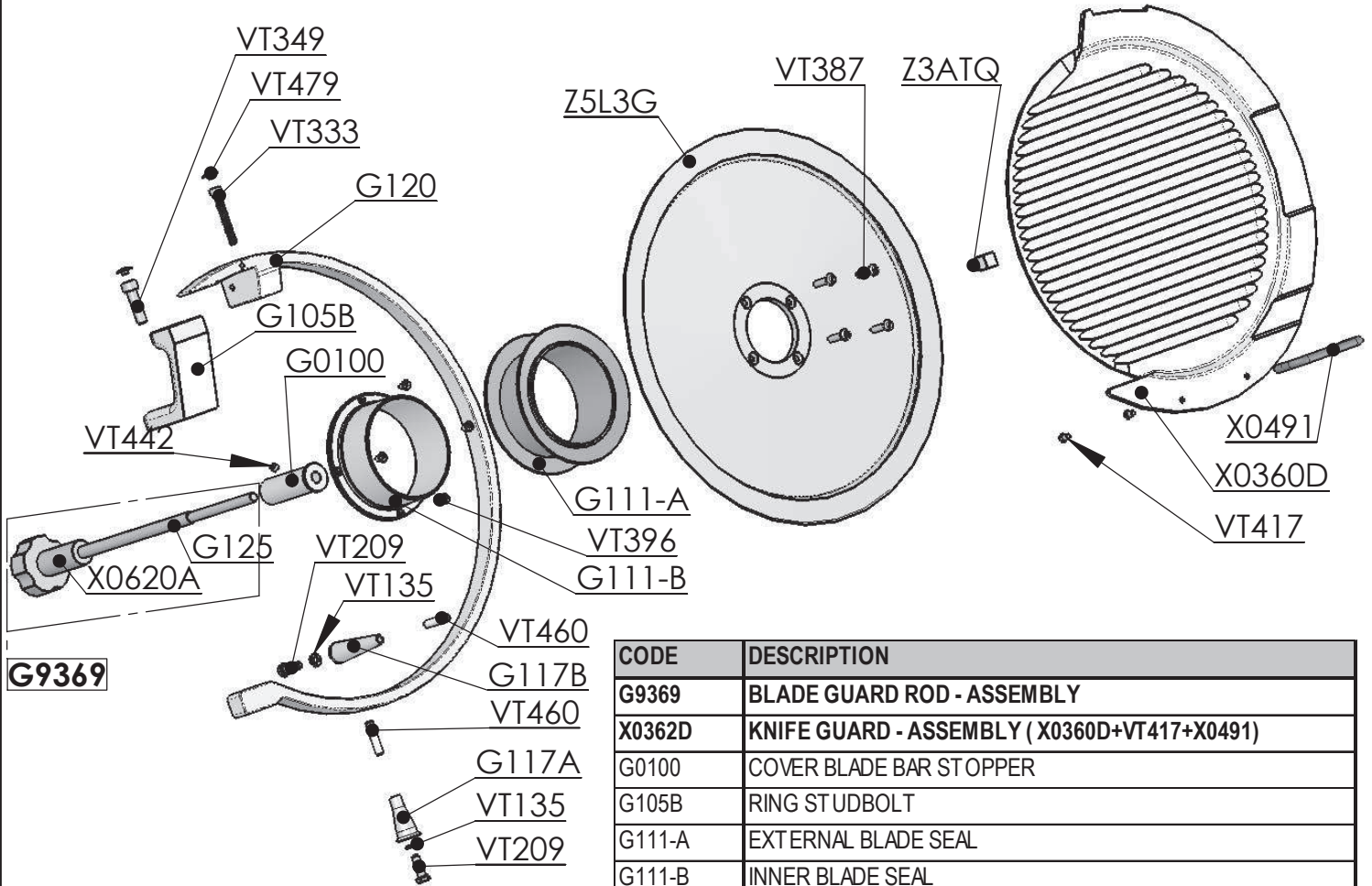

CODE	DESCRIPTION
<b>G9369</b>	<b>BLADE GUARD ROD - ASSEMBLY</b>
<b>X0362D</b>	<b>KNIFE GUARD - ASSEMBLY ( X0360D+VT417+X0491)</b>
G0100	COVER BLADE BAR STOPPER
G105B	RING ST UDBOLT
G111-A	EXTERNAL BLADE SEAL
G111-B	INNER BLADE SEAL
G117A	SPACER-PROTECTION RING L 38MM
G117B	SPACER-PROTECTION RING L 58MM
G120	KNIFE RING
G125	BLADE GUARD ROD
VT086	HEX NUT M6-1.0 SS
VT135	FLAT WASHER LG OD d.6-18od SS
VT209	HEX HEAD SCREW M6-1.0x20 SS
VT333	HEX SOCKET HEAD SCREW M6-1.0x45 SS
VT349	HEX SOCKET HEAD SCREW M8-1.25x16 SS
VT387	SLOTTED OVAL COUNTERSUNK HEAD M5-0.8x16 SS
VT396	PHILLIPS FLAT COUNTERSUNK HEAD M4-0.7x8 SS
VT417	CYLINDRICAL FLAT HEAD FOR SCREW DRIVER M4-0.7x10 SS
VT442	HEX SOCKET SET SCREW CUP POINT M6-1.0x6 SS
VT460	HEX SOCKET SET SCREW FLAT POINT M6-1.0x20 SS
VT479	PROTECTIVE CAP d.15.5-4.1x3
X0360D	KNIFE GUARD
X0491	HANDLE - COVER BLADE
X0620A	ALU KNOB - BLADE GUARD ROD
Z3ATQ	KNIFE GUARD LOCKING SCREW
Z5L3G	KNIFE 350 mm 14" (3RD GEN.)

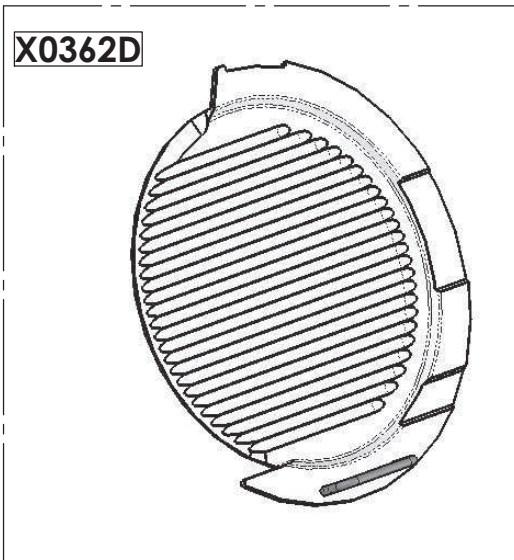

**STANDARD 8 - 2010**

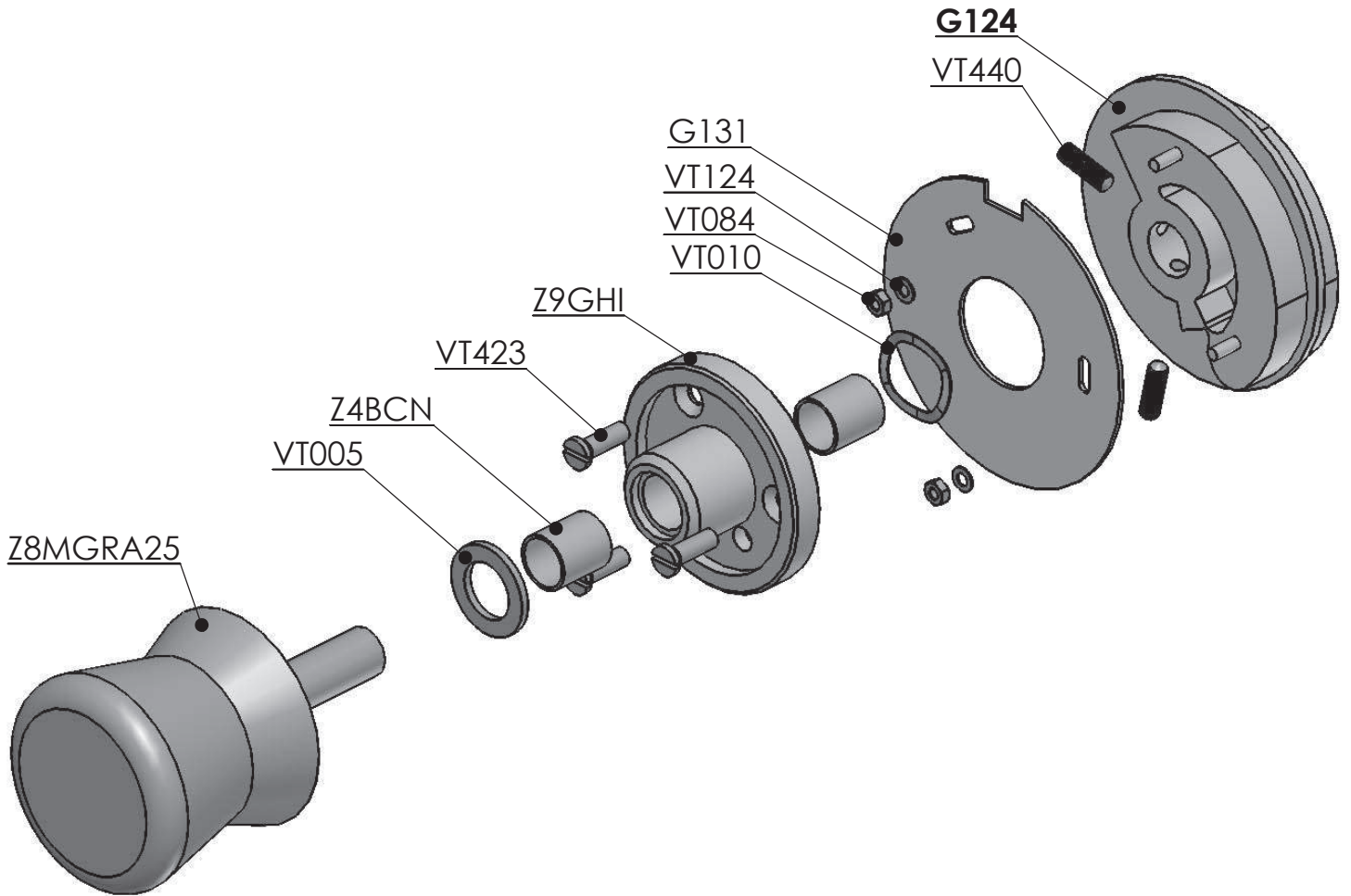

CODE	DESCRIPTION
<b>G124</b>	<b>CAM INDEXING 25mm + VT440</b>
G131	SPACER CAM
VT005	SPACER RING d. 18-25x1 SS
VT010	SPRING WASCHER d. d.18.5-32x0.3 BLACK
VT124	FLAT WASHER M4 SS
VT282	HEX HEAD TAPPING SCREW 4,8x13 ISO 1479-DIN 7976 C
VT414	CYLINDRICAL FLAT HEAD FOR SCREWDRIVER M5-0.8x8 SS
VT440	HEX SOCKET SET SCREW CUP POINT M6-1.0x16 SS
Z4BCN	BUSHING 18 - 20 - 15
Z8MGRA25	ADJUSTABLE ALU KNOB INDEXING 0 - 25 mm
Z9GHI	KNOB SPACER 76,6

**STANDARD 8 - 2010**

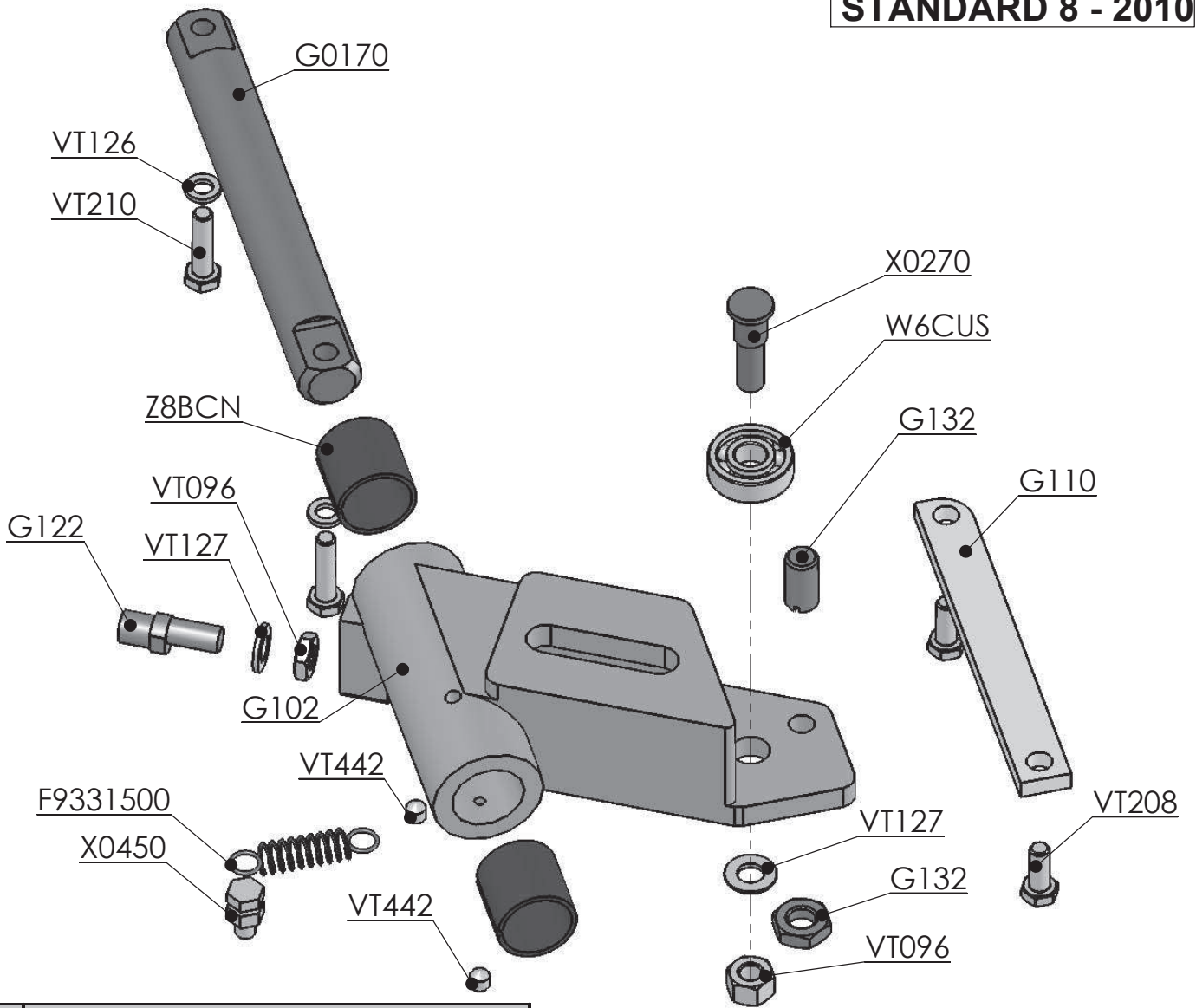

CODE	DESCRIPTION
<b>G9361A</b>	<b>SLIDE INDEX ASSEMBLY (G102+Z8BCN+VT442)</b>
F9331500	SPRING d 10 L 55
G0170	ROD - INDEX SLIDE
G102	SLIDE - INDEX MECHANISM
G103	PIN - INDEX CAM D8
G110	ROD - INDEX ANTI ROTATION
G122	PIN - INDEX CAM D10
G132	GUIDE INDEX MECHANISM (SCREW M12-1.0x18+NUT)
VT096	HEX JAM NUT M8-1.25 SS
VT126	FLAT WASHER M6 SS
VT127	FLAT WASHER M8 SS
VT208	HEX HEAD SCREW M6-1.0x16 SS
VT210	HEX HEAD SCREW M6-1.0x25 SS
VT442	HEX SOCKET SET SCREW CUP POINT M6-1.0x6 SS
W6CUS	SS BEARING 6000 ZZ 10 x 20 X 6
X0270	BEARING PING 10 x 30 M6
X0450	SPRING PIN
Z8BCN	BUSHING 20 23 20E

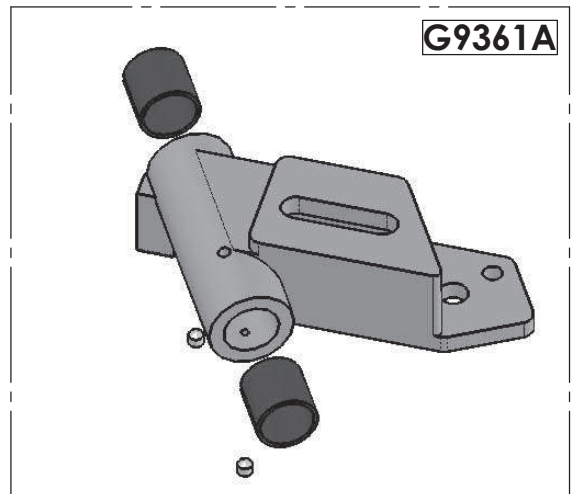

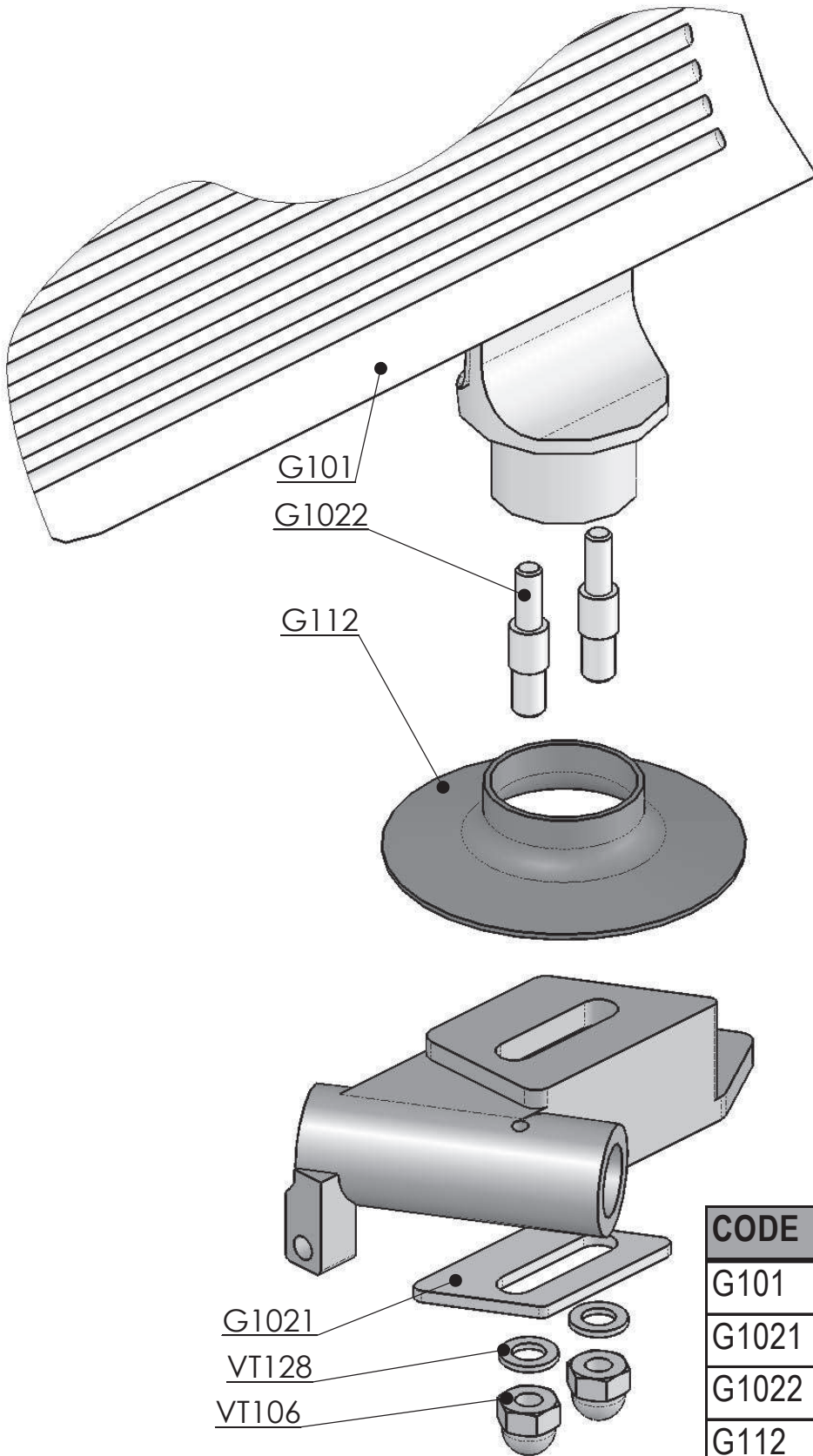

CODE	DESCRIPTION
G101	GAUGE PLATE
G1021	SS PLATE STRENGTHENING
G1022	LOCKING PLATE SCREW
G112	GAUGE PLATE PROTECTION
VT 106	ACORN HEX CAP M10-1.5 SS
VT 128	FLAT WASHER M10 SS





**BIRO  
B 350 GCO  
AUTOMATIC SLICER**



**STANDARD 8 - 2010**

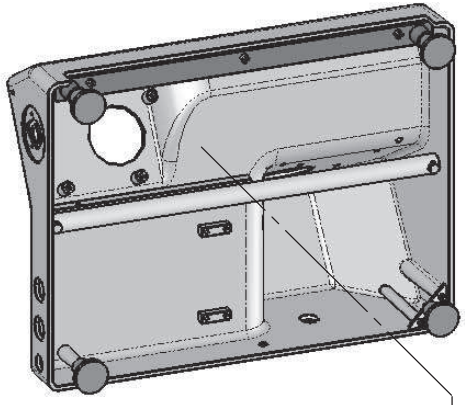
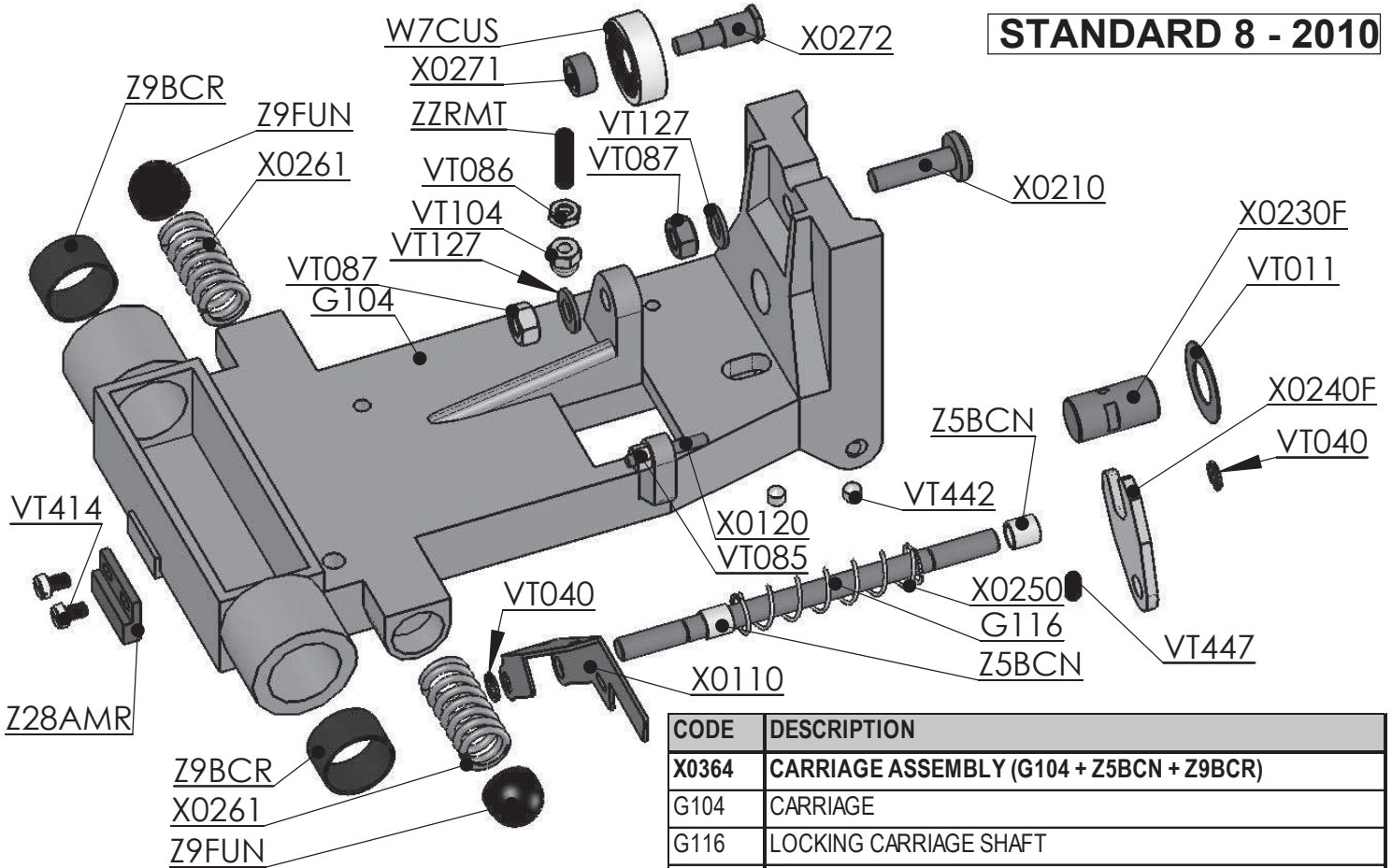

**X0364 CARRIAGE ASSEMBLY**

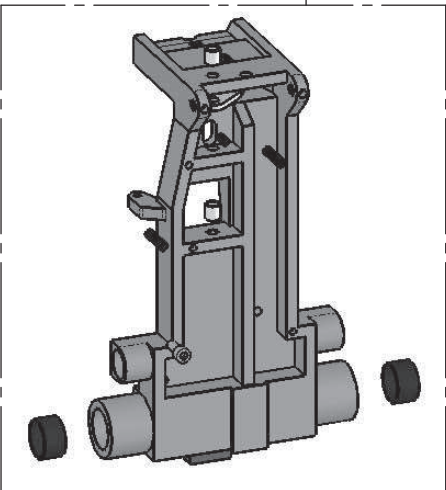

CODE	DESCRIPTION
<b>X0364</b>	<b>CARRIAGE ASSEMBLY (G104 + Z5BCN + Z9BCR)</b>
G104	CARRIAGE
G116	LOCKING CARRIAGE SHAFT
VT011	SPACER RING 16-30-1
VT040	E-CLIP M 6 SS
VT085	HEX NUT M5-0.8 SS
VT086	HEX NUT M6-1.0 SS
VT087	HEX NUT M8-1.25 SS
VT104	ACORN HEX CAP M6-1.0 SS
VT127	FLAT WASHER M8 SS
VT414	CYLINDRICAL FLAT HEAD FOR SCREW DRIVER M5-0.8x8 SS
VT442	HEX SOCKET SET SCREW CUP POINT M6-1.0x6 SS
VT447	HEX SOCKET SET SCREW CONE POINT M5-0.8x8 SS
W7CUS	BEARING
X0110	BRACKET
X0120	GUIDE PIN
X0210	CAP SCREW
X0230F	LOCKING SUPPORT TRAY ASSY
X0240F	LOCKING SHAFT MECHANISM
X0250	SPRING - LOCKING CARRIAGE
X0261	SPRING - CARRIAGE L 45mm
X0271	SPACER - BEARING
X0272	BEARING PIN
X0520	LOCKING SHAFT MEC. PART 2
Z28AMR	MAGNET
Z5BCN	BUSHING10 8 10 E
Z9BCR	BUSHING 25 28 25 E
Z9FUN	BUMPER - SLIDE ROD
ZZRMT	SCREW M6-1.0x20



**BIRO  
B 350 GCO  
AUTOMATIC SLICER**



**STANDARD 8 - 2010**

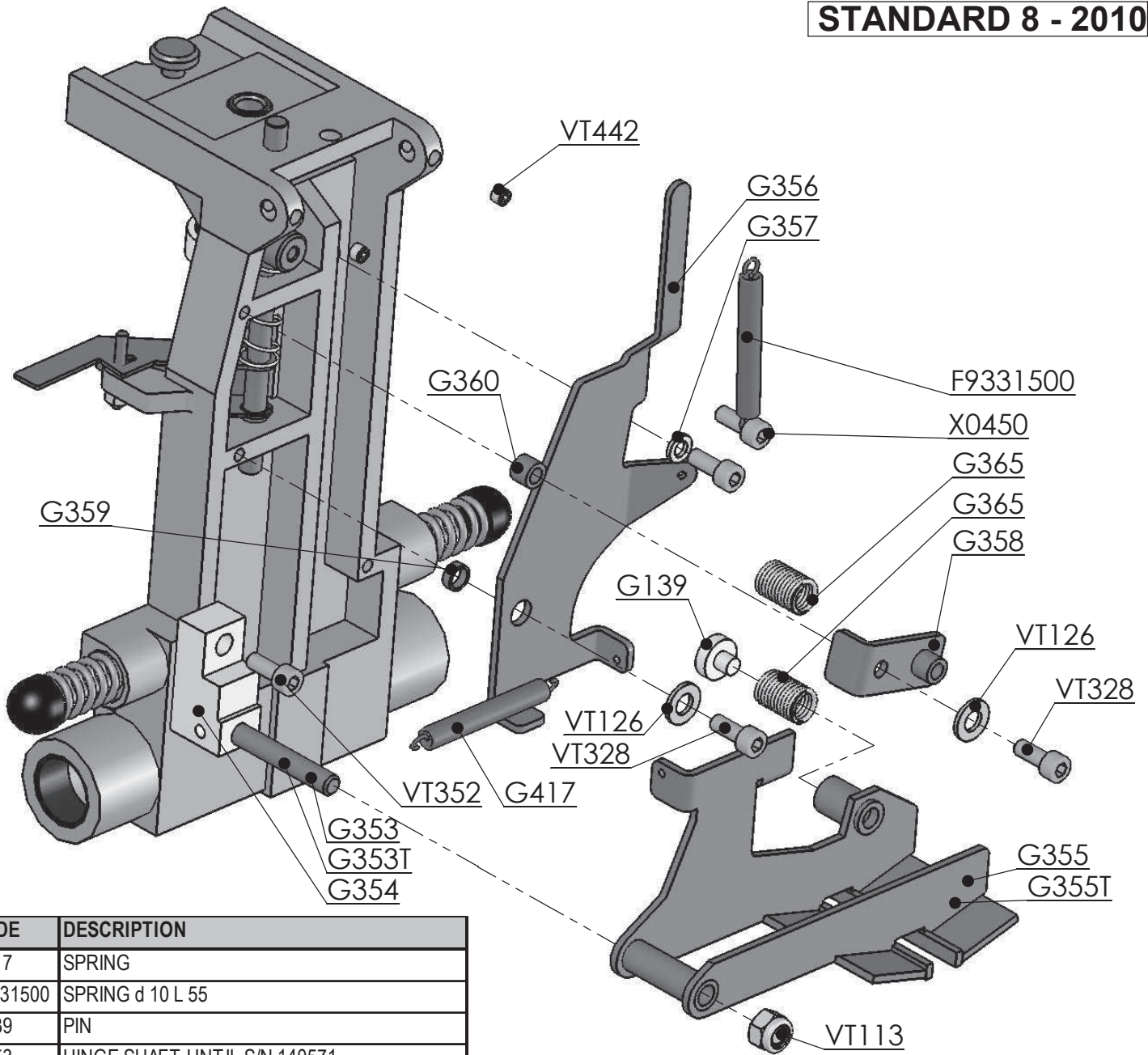

CODE	DESCRIPTION
G417	SPRING
F9331500	SPRING d 10 L 55
G139	PIN
G353	HINGE SHAFT UNTIL S/N 140571
G353T	HINGE SHAFT FROM S/N 140572
G354	HINGE SHAFT SUPPORT
G355	SLIDING GUIDE UNTIL S/N 140571
G355T	SLIDING GUIDE FROM S/N 140572
G356	CLUTCH LEVER
G357	STOP DISK UNTIL S/N 140571
G358	KEY
G359	LEVER SPACER
G360	KEY SPACER
G365	PUSH LEVER SPRING
VT 113	NYLOK NUT M8-1.25 SS
VT 126	FLAT WASHER M6 SS
VT 328	HEX SOCKET HEAD SCREW M6-1.0x20 SS
VT 352	HEX SOCKET HEAD SCREW M8-1.25x30 SS
VT 442	HEX SOCKET SET SCREW CUP POINT M6-1.0x6 SS
X0450	SPRING PIN

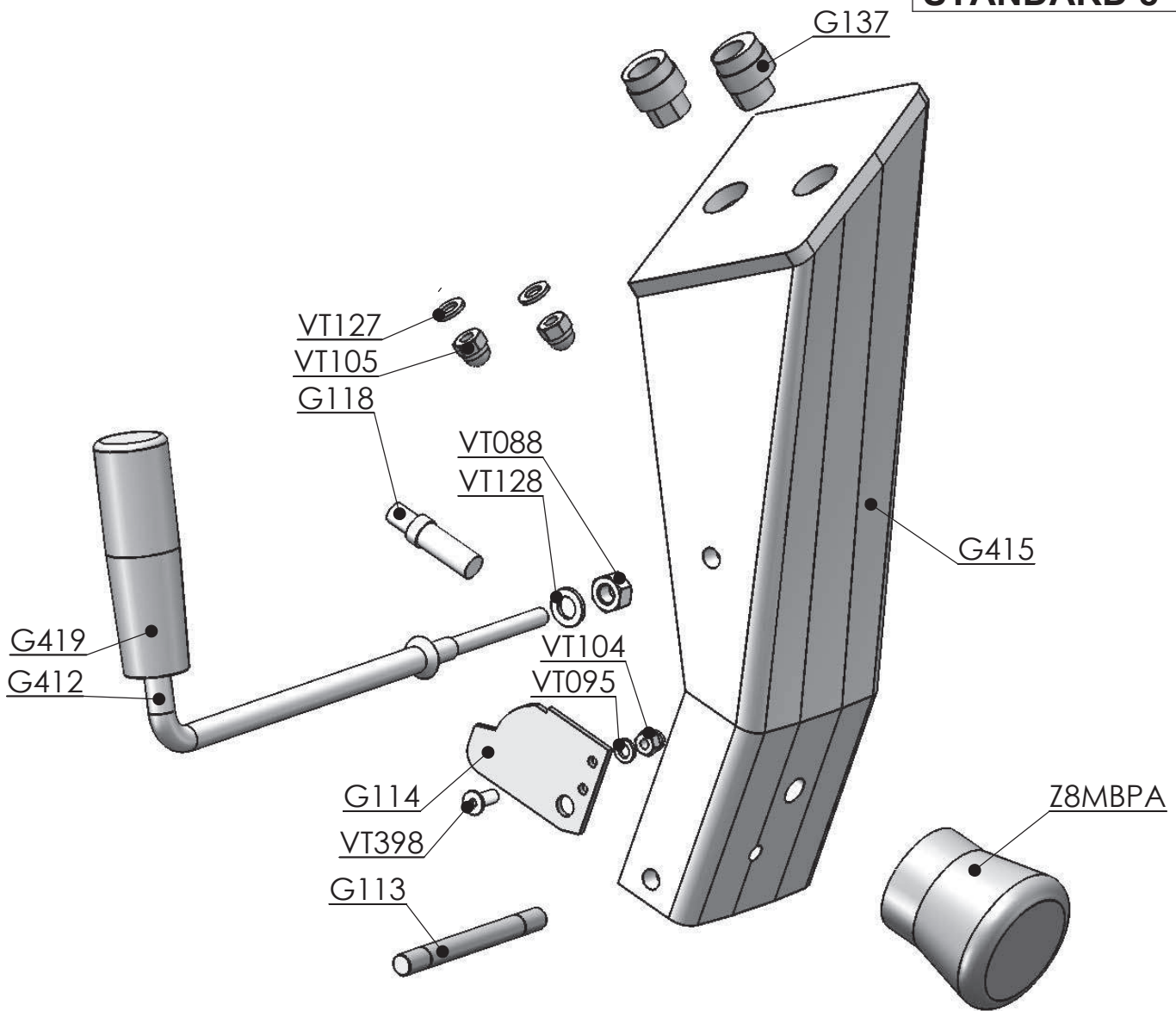

CODE	DESCRIPTION
G113	SHAFT PIVOT RETURN
G114	LOCKING CARRIAGE PLATE
G118	KNOB SHAFT
G137	REGULATION SHAFT
G412	HANDLE -SHAFT - CARRIAGE
G415	SUPPORT - TRAY ASSY
G419	HANDLE - CARRIAGE
VT088	HEX NUT M10-1.5 SS
VT095	HEX JAM NUT M6-1.0 SS
VT104	ACORN HEX CAP M6-1.0 SS
VT105	ACORN HEX CAP M8-1.25 SS
VT127	FLAT WASHER M8 SS
VT128	FLAT WASHER M10 SS
VT398	HEX SOCKET SLOTTED FLAT HEAD M6-1.0x16 SS
Z8MBPA	ALU KNOB - SUPPORT TRAY

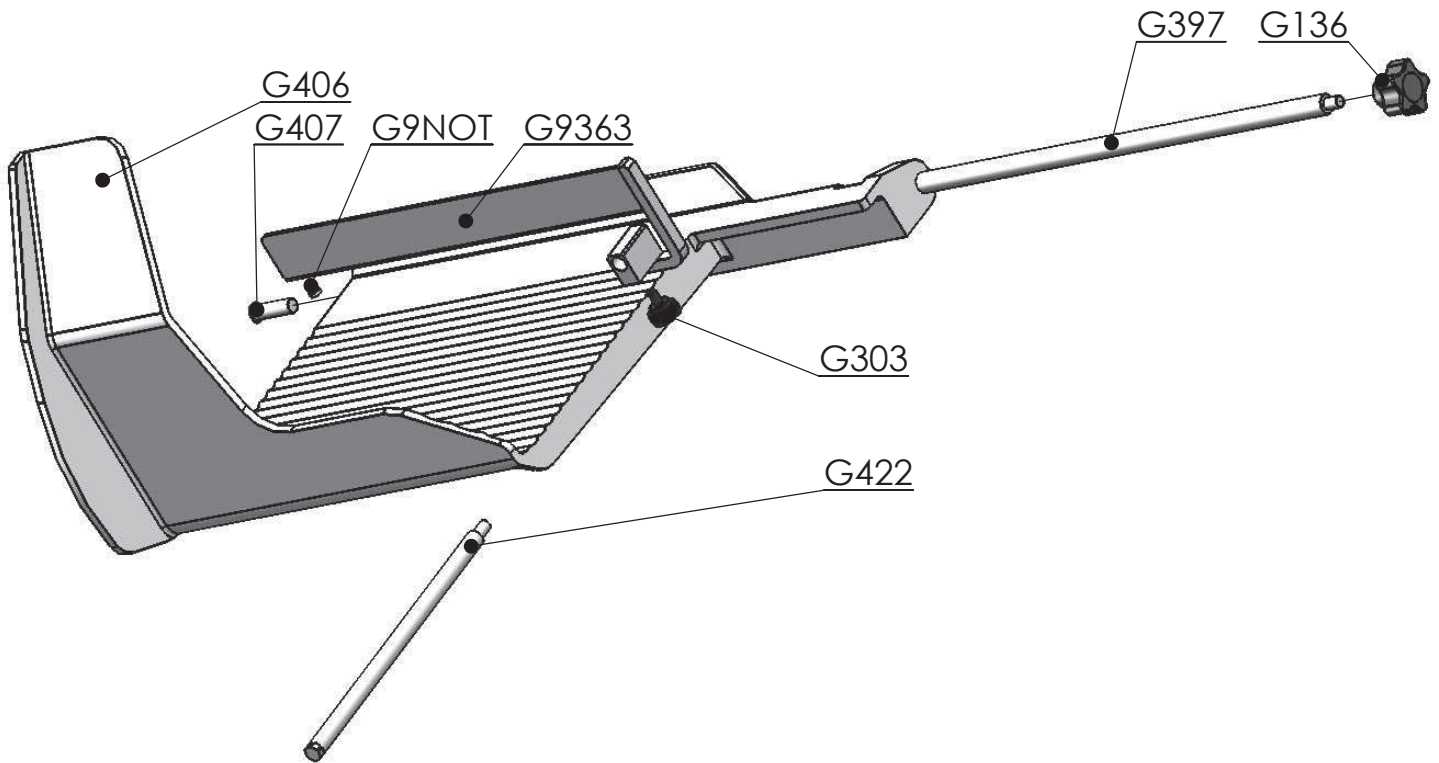

CODE	DESCRIPTION
G136	ALU KNOB
G303	KNOB - LOCKING FENCE ASSEMBLY
G397	SLIDE ROD ASSY
G406	CARRIAGE TRAY
G407	PIN
G422	FENCE SHAFT
G9363	FENCE
G9NOTB	BUMPER
VT458	HEX SOCKET SET SCREW FLAT POINT M8-1.25x35 SS



**BIRO  
B 350 GCO  
AUTOMATIC SLICER**



**STANDARD 8 - 2010**

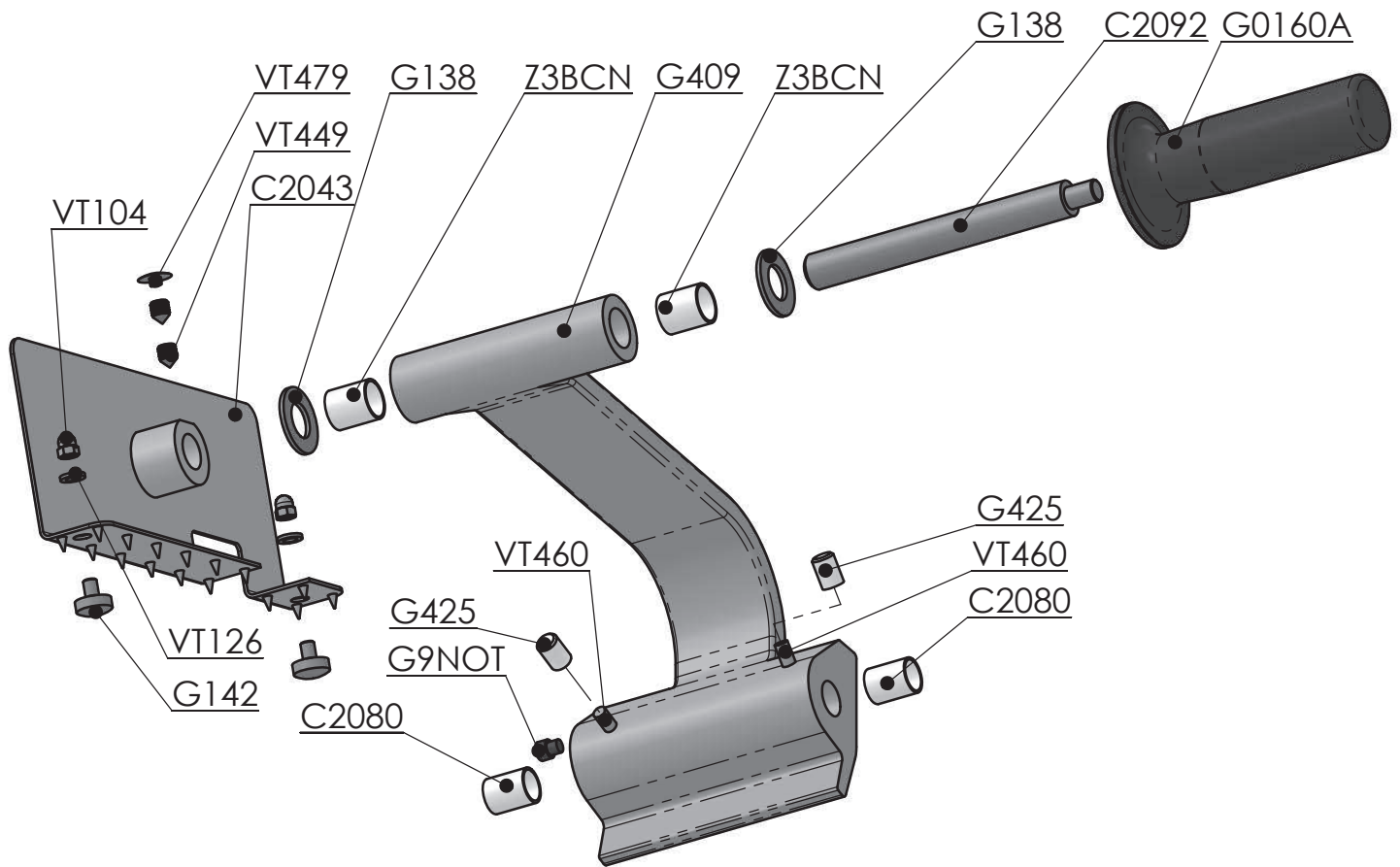

**X0363 GRIP HOLDER ASSEMBLY**

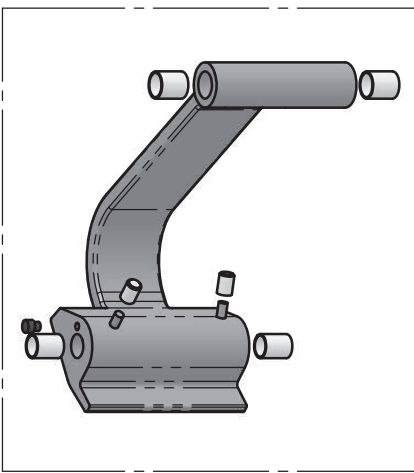

CODE	DESCRIPTION
X0363	GRIP HOLDER ASSEMBLY ( G409+C2080+G9NOT+G425+VT460+Z3BCN )
C2043	PRODUCT GRIP
C2080	BUSHING 14-16-20 E
C2092	HANDLE BAR
G0160A	ALUMINUM HANDLE
G138	SEAL
G142	PLASTIC SLIDING PIN
G409	PRODUCT GRIP HOLDER
G425	PLASTIC CAP
G9NOT	BUMPER
VT104	ACORN HEX CAP M6-1.0 SS
VT126	FLAT WASHER M6 SS
VT449	HEX SOCKET SET SCREW CONE POINT M8-1.25x8 SS
VT460	HEX SOCKET SET SCREW FLAT POINT M6-1.0x20 SS
VT479	PROTECTIVE CAP d.15.5-4.1x3
Z3BCN	BUSHING 16-18-20 E

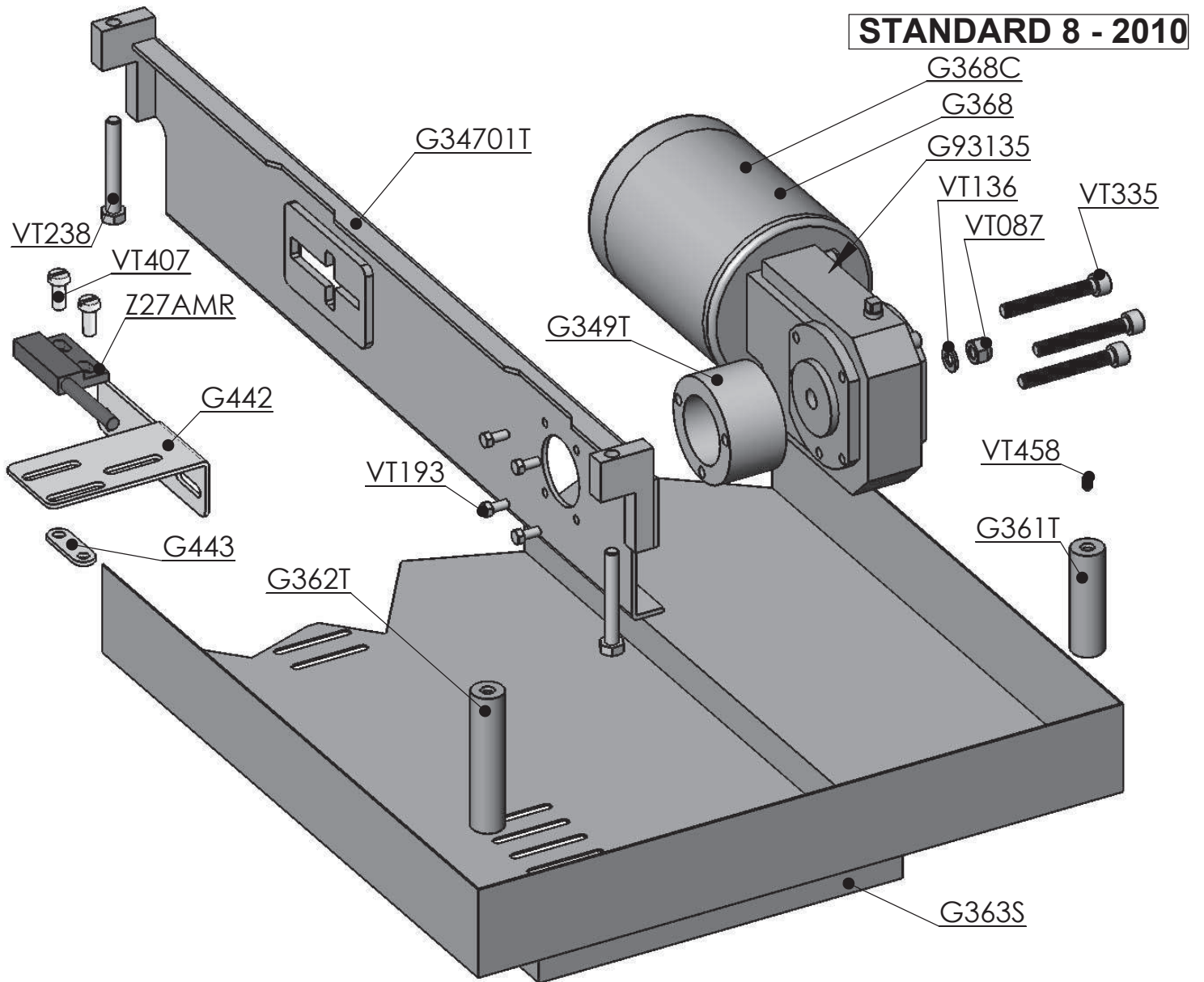

CODE	DESCRIPTION
G34701T	SLIDING PLATE
G349T	MOTOR GEAR FLANGE
G361T	SS PIVOT SPACER 20x96 M8
G362T	SS PIVOT SPACER 20x124 M8
G363S	COVER 93mm HIGH FOR LIFT DEVICE
G368	AUTOMAT MOTOR 230V
G368C	AUTOMAT MOTOR 115V
G442	SUPPORT PLATE
G443	SUPPORT PLATE
G93135	MOTOR GEAR TRANSMISSION
VT087	NUT M8-1.25 SS
VT193	HEX HEAD SCREW M5-0.8x12 SS
VT238	HEX HEAD SCREW M8-1.25x60 SS
VT335	HEX SOCKET HEAD SCREW M6-1.0x55 SS
VT407	CYLINDRICAL FLAT HEAD FOR SCREW DRIVER M4-0.7x10 SS
VT458	HEX SOCKET SET SCREW FLAT POINT M8-1.25x35 SS
Z27AMR	HOUSING SENSOR



**BIRO  
B 350 GCO  
AUTOMATIC SLICER**



**STANDARD 8 - 2010**

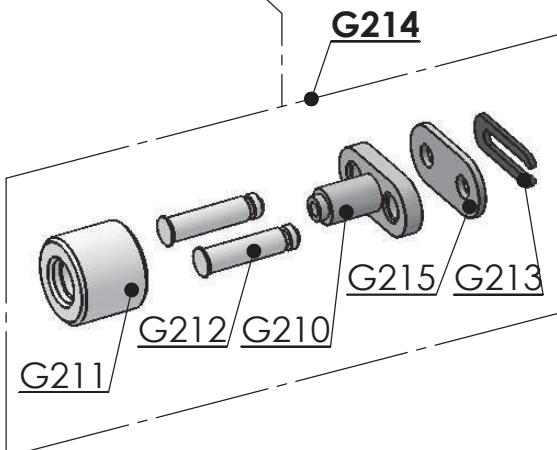
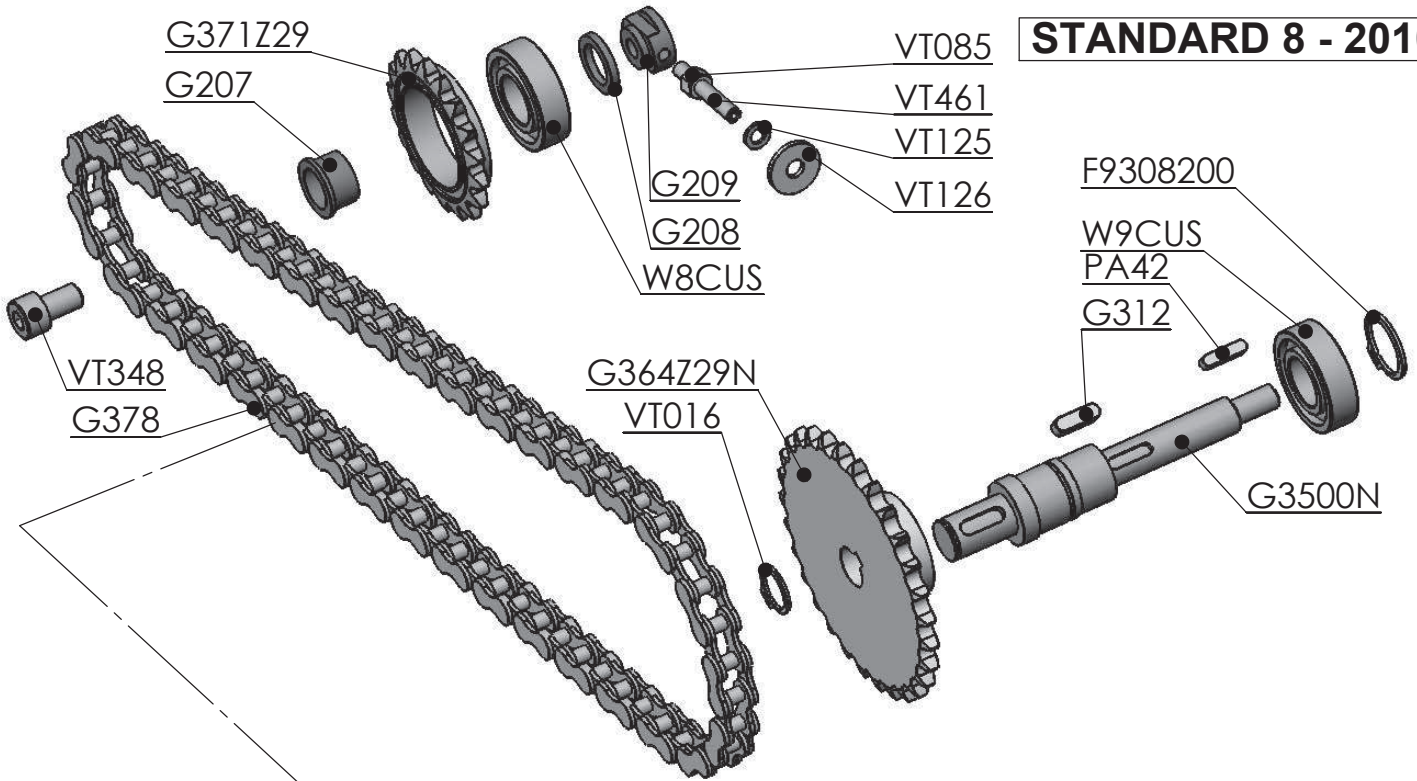

CODE	DESCRIPTION
<b>G214</b>	<b>PIN ASSEMBLY</b>
F9308200	RETAINING RING EXTERNAL M20 SS
G207	BUSHING
G208	CARRIAGE MOVEMENT SPACER
G209	NUT
G210	CONNECTING CHAIN
G211	PIN
G212	PIN
G213	CLIP
G215	EXTERNAL PLATE CHAIN 3/8"
G312	KEY 5x5x16 STAINLESS STEEL
G3500N	GEAR SHAFT
G364NZ29	CARRIAGE MOTOR PINION Z 29
G371Z29	MOTOR PINION Z 29
G378	CHAIN 3,8" - 83 p - mm 790,6
PA42	KEY 4x4x16 STAINLESS STEEL
VT016	RETAINING RING EXTERNAL M14 SS
VT085	HEX NUT M5-0.8 SS
VT125	FLAT WASHER M5 SS
VT126	FLAT WASHER M6 SS
VT348	HEX SOCKET HEAD SCREW M8-1.25x14 SS
VT461	HEX SOCKET SET SCREW FLAT POINT M5-0.8x35 SS
W8CUS	BEARING - 6003 SS 2 RS1
W9CUS	BEARING - 6004 SS 2RS1



BIRO  
B350 GCO  
AUTOMATIC SLICER



STANDARD 8 - 2010

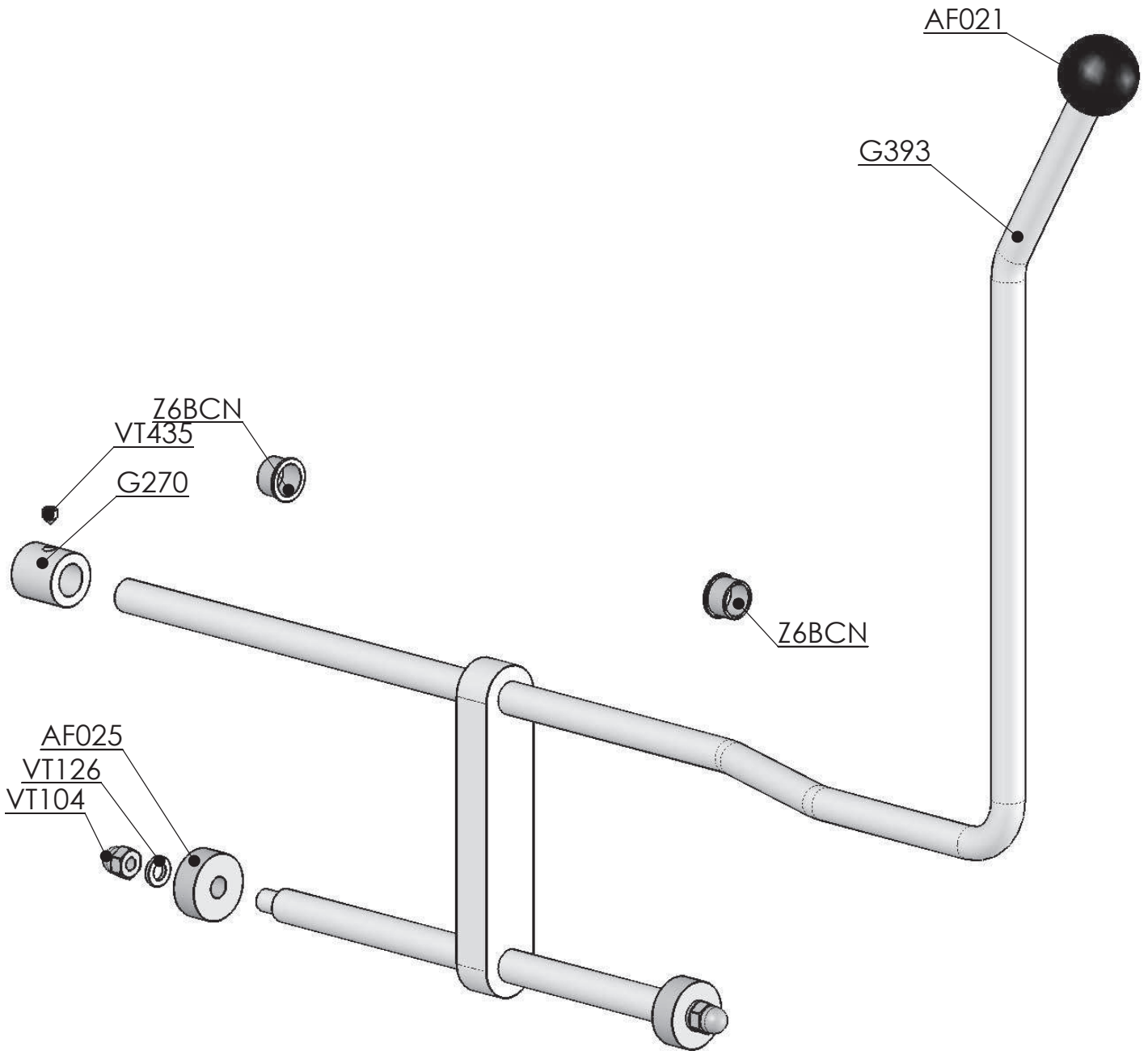

CODE	DESCRIPTION
AF021	KNOB $\varnothing$ 40 M10
AF025	PLASTIC WHEEL
G270	LEVER SPACER
G393	LIFT LEVER
VT 104	ACORN HEX CAP M6-1.0 SS
VT 126	FLAT WASHER M6 SS
VT 435	HEX SOCKET SET SCREW CUP POINT M5-0.8x5 SS
Z6BCN	BUSHING 12 14 9



**STANDARD 8 - 2010**

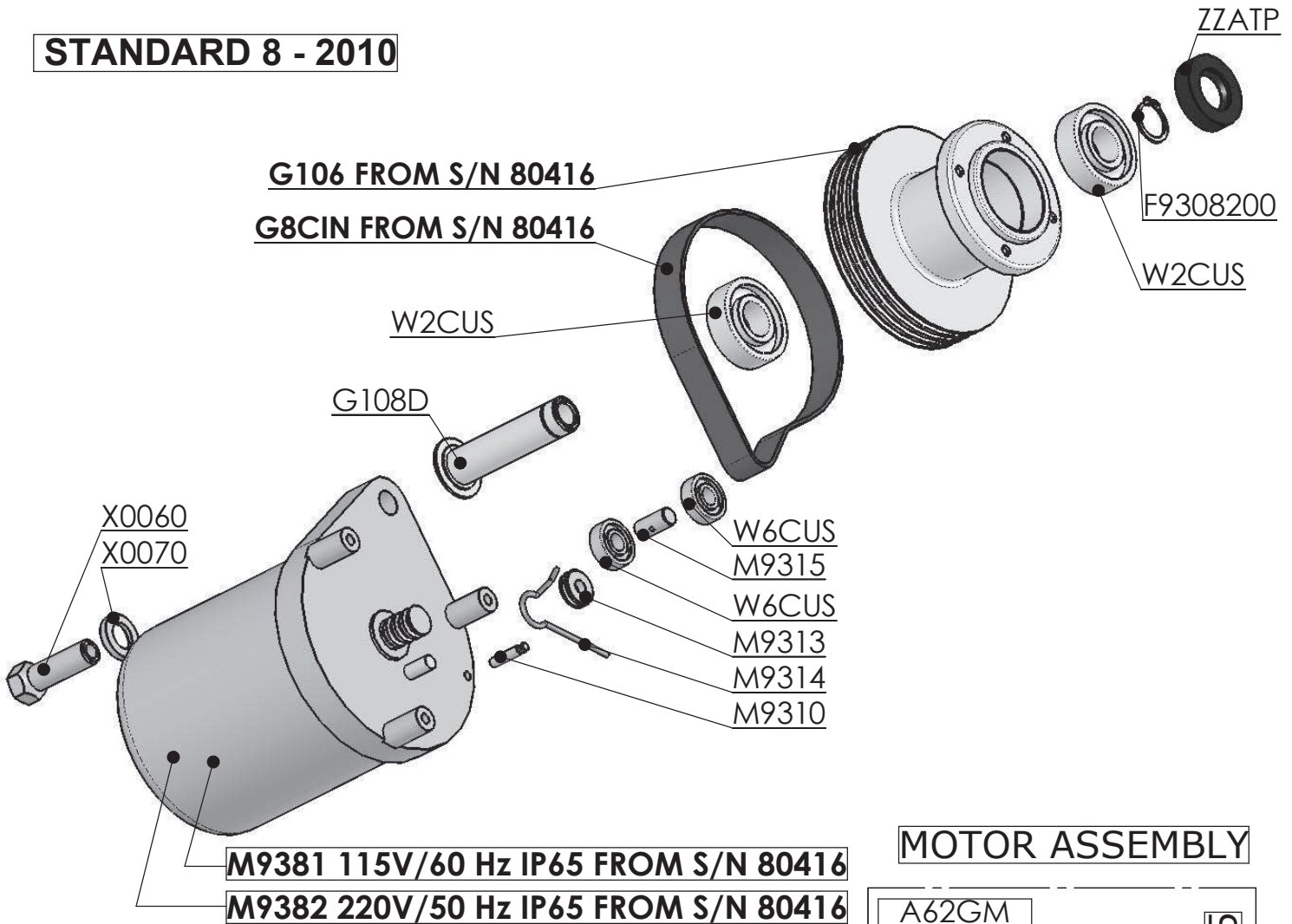

**MOTOR ASSEMBLY**

CODE	DESCRIPTION
F9308200	RETAINING RING EXTERNAL M20 SS
G106	PULLEY B350M FROM S/N 80416
G108D	SHAFT - KNIFE 29 x 97
G8CIN	BELT PJ 406 J9 FROM S/N 80416
M9310	PIN 25 x 5
M9313	RING SUPPORTING SPRING 20 x 6
M9314	BEARING TENS. SPRING
M9315	BEARING PIN
M9381	MOTOR - IP 65 115 VOLT 60 Hz
M9382	MOTOR - IP 65 220 VOLT 50 Hz
W2CUS	SS TRANSMISSION BEARING
W6CUS	SS BEARING 6000 ZZ 10 x 20 X 6
X0060	CAP SCREW
X0070	LOCK WASHER
ZZATP	SEAL
CODE	DESCRIPTION
A62GM	MOTOR ASSEMBLY IP 65 115V/60Hz
A63GM	MOTOR ASSEMBLY IP 65 220V/50Hz

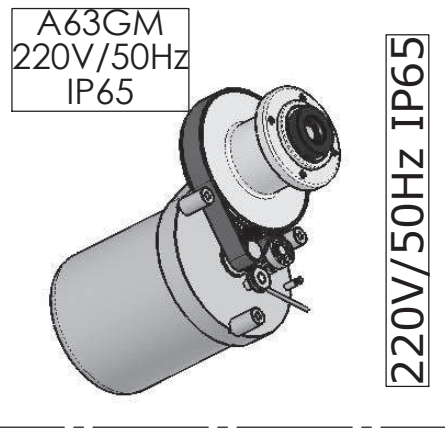
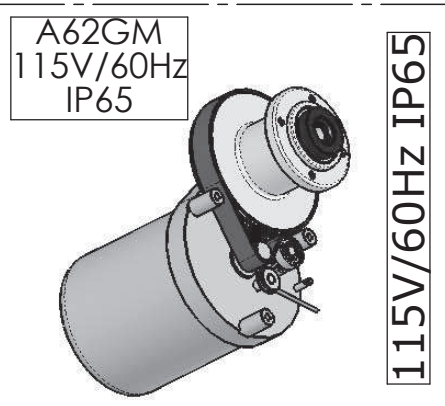

**STANDARD 8 - 2010**

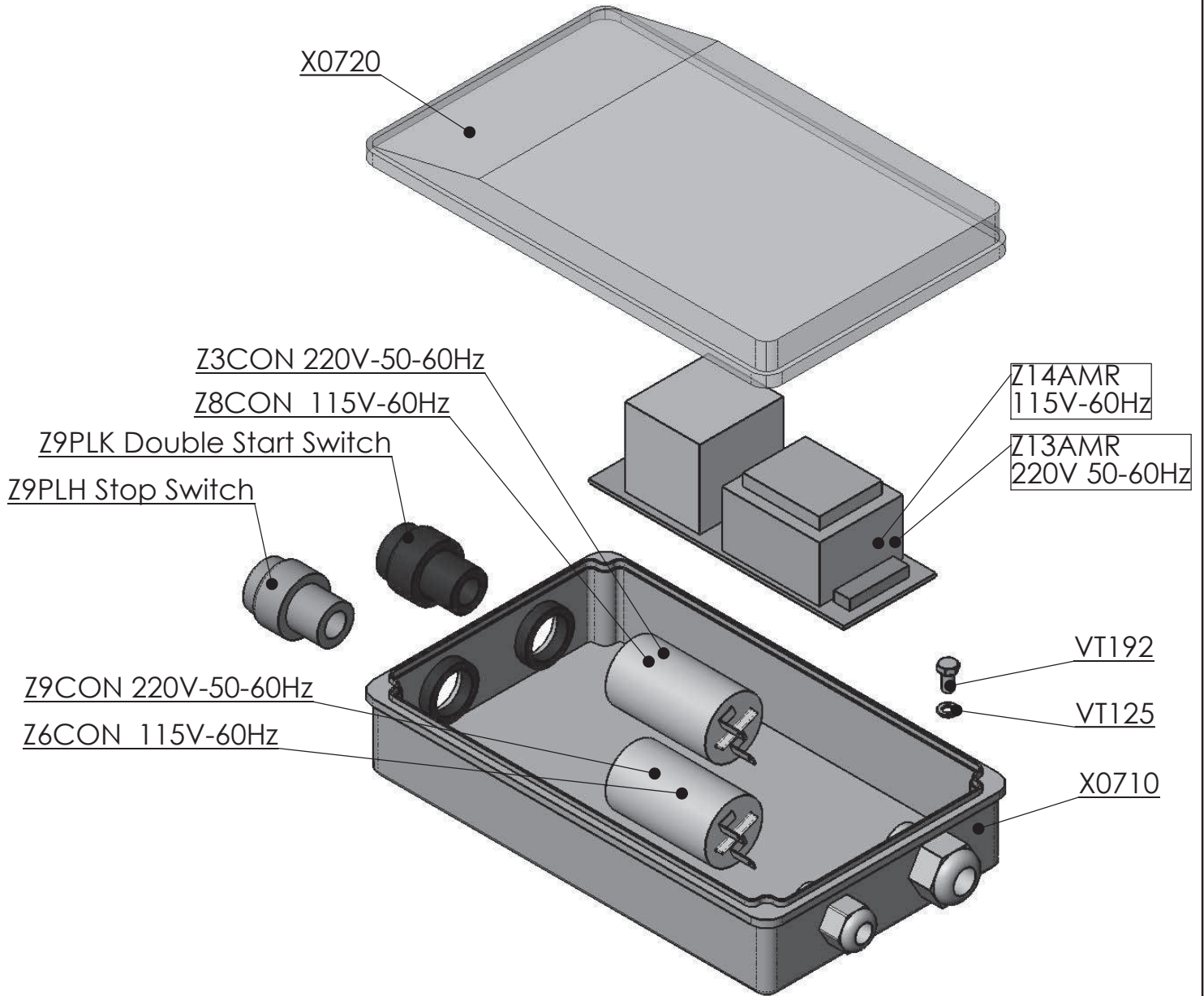

CODE	DESCRIPTION
VT125	FLAT WASHER M5 SS
VT192	HEX HEAD SCREW M5-0.8x10 SS
X0710	ELECTRIC BOX - BASE
X0720	PLASTIC COVER
Z3CON	CAPACITOR 10 Mf 220V-50/60Hz
Z6CON	CAPACITOR 25 Mf 115V-60Hz
Z8CON	CAPACITOR 30 Mf 115V-60Hz
Z9CON	CAPACITOR 6,3 Mf 220V-50/60Hz
Z9PLH	STOP SWITCH - IP 69 RED
Z9PLK	DOUBLE START SWITCH - IP 69
Z13AMR	CARD 220V/50-60Hz
Z14AMR	CARD 115V/60Hz



# BIRO AUTOMATIC SLICER



## STANDARD 8 - 2010

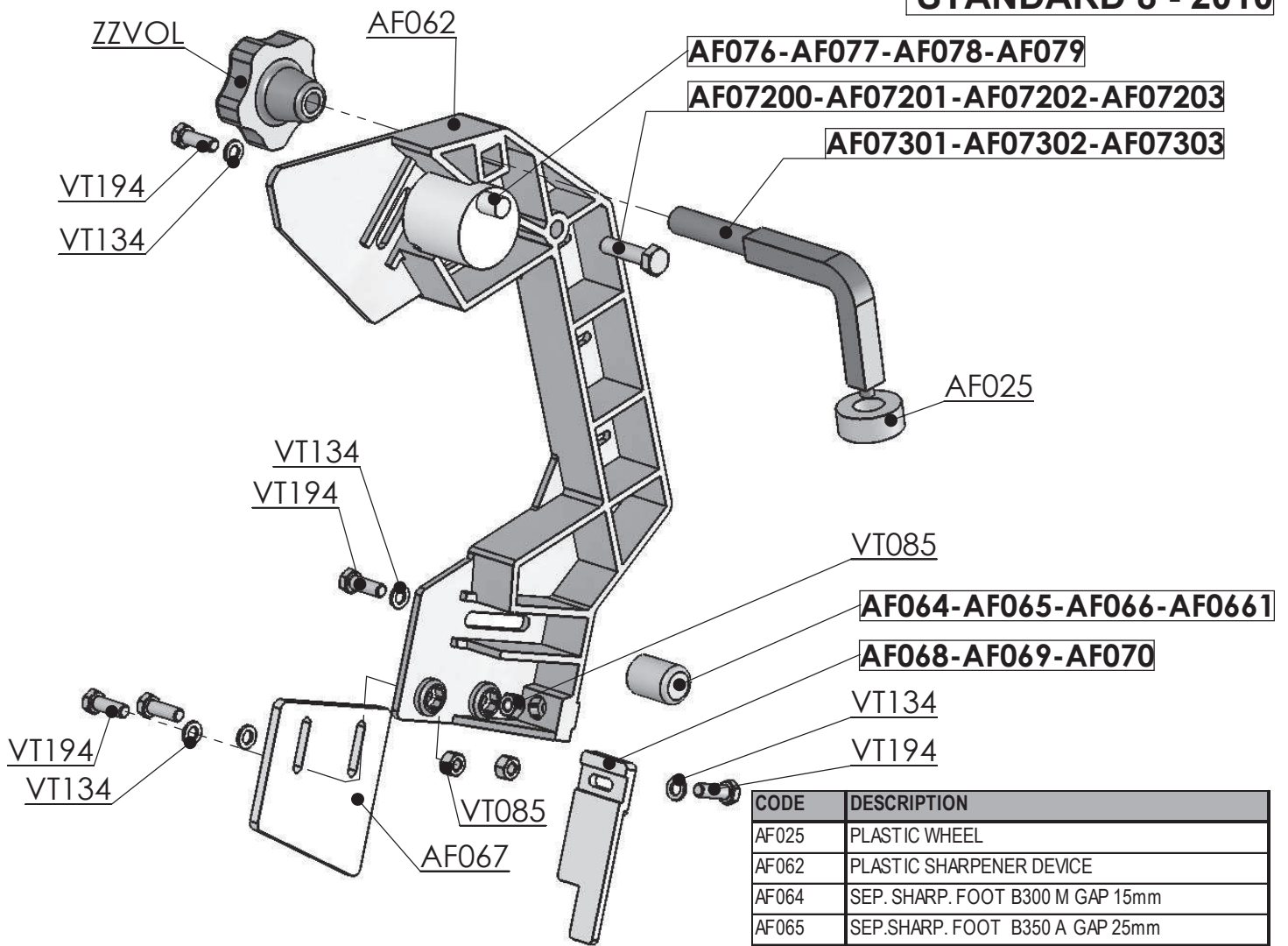

### Complete Assembly

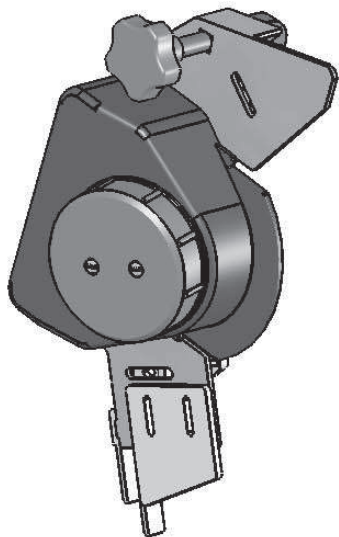

**AF01US-AF02US  
AF03US-AF04US**

CODE	DESCRIPTION
AF025	PLASTIC WHEEL
AF062	PLASTIC SHARPENER DEVICE
AF064	SEP. SHARP. FOOT B300 M GAP 15mm
AF065	SEP.SHARP. FOOT B350 A GAP 25mm
AF066	SEP. SHARP. FOOT B 350 MV/GAP 25mm
AF0661	SEP.SHARP. FOOT B350 M GAP 30mm
AF067	SEP.SHARP. COVER PLATE - ALL
AF068	PROTECTION B300 M
AF069	PROTECTION B350 M / B350 A
AF070	PROTECTION B350 MV
AF07200	PIN B300 M
AF07201	PIN B350 MV
AF07202	PIN B350 A
AF07203	PIN B350M
AF07301	LOCKING SHAFT B350 MV/B350 A
AF07302	LOCKING SHAFT B300 M
AF07303	LOCKING SHAFT B350 M
AF076	REFERING FOOT B300 M
AF077	REFERING FOOT B350 A
AF078	REFERING FOOT B350 MV
AF079	REFERING FOOT B350 M
VT 134	FLAT WASHER LG OD d.5-15od SS
VT 194	HEX HEAD SCREW M5-0.8x14 SS
ZZVOL	KNOB
<b>ASSEMBLY</b>	
AF01US	COMPLETE ASS.BLY B350 A (25mm OPENING)
AF02US	COMPLETE ASS.BLY B300 M
AF03US	COMPLETE ASS.BLY B350 MV
AF04US	COMPLETE ASS.BLY B350 M (30 mm OPENING)

**STANDARD 8 - 2010**

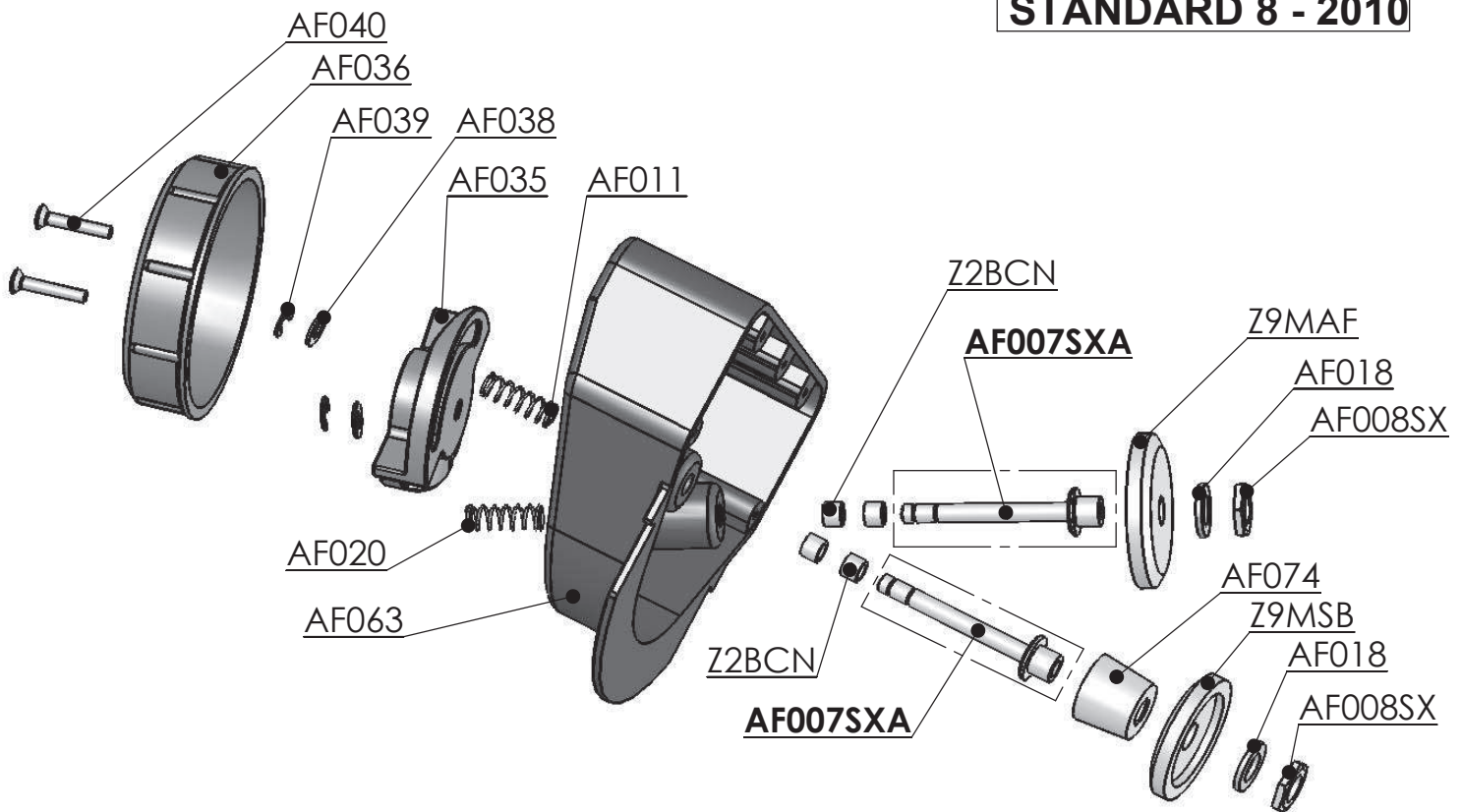

CODE	DESCRIPTION
<b>AF007SXA</b>	<b>SHAFT ASSEMBLY ( AF006 + AF007SX)</b>
AF008SX	NUT - SPECIAL
AF011	SPRING - CLEANING STONE
AF018	SEAL RING
AF020	SPRING - SHARPENING STONE
AF035	SHARPENER CAM
AF036	KNOB - SHARPENER
AF038	WASHER - PLASTIC
AF039	RING - RETAINER - UNI 7434
AF040	SLOTTED FLAT COUNTERSUNK HEAD M5-0.8x10 SS
AF063	SEPARATED SHARPENER BOX
AF074	DUST COVER ALL
Z2BCN	BUSH 06-08-06
Z9MAF	STONE - SHARPENING
Z9MSB	CLEANING STONE

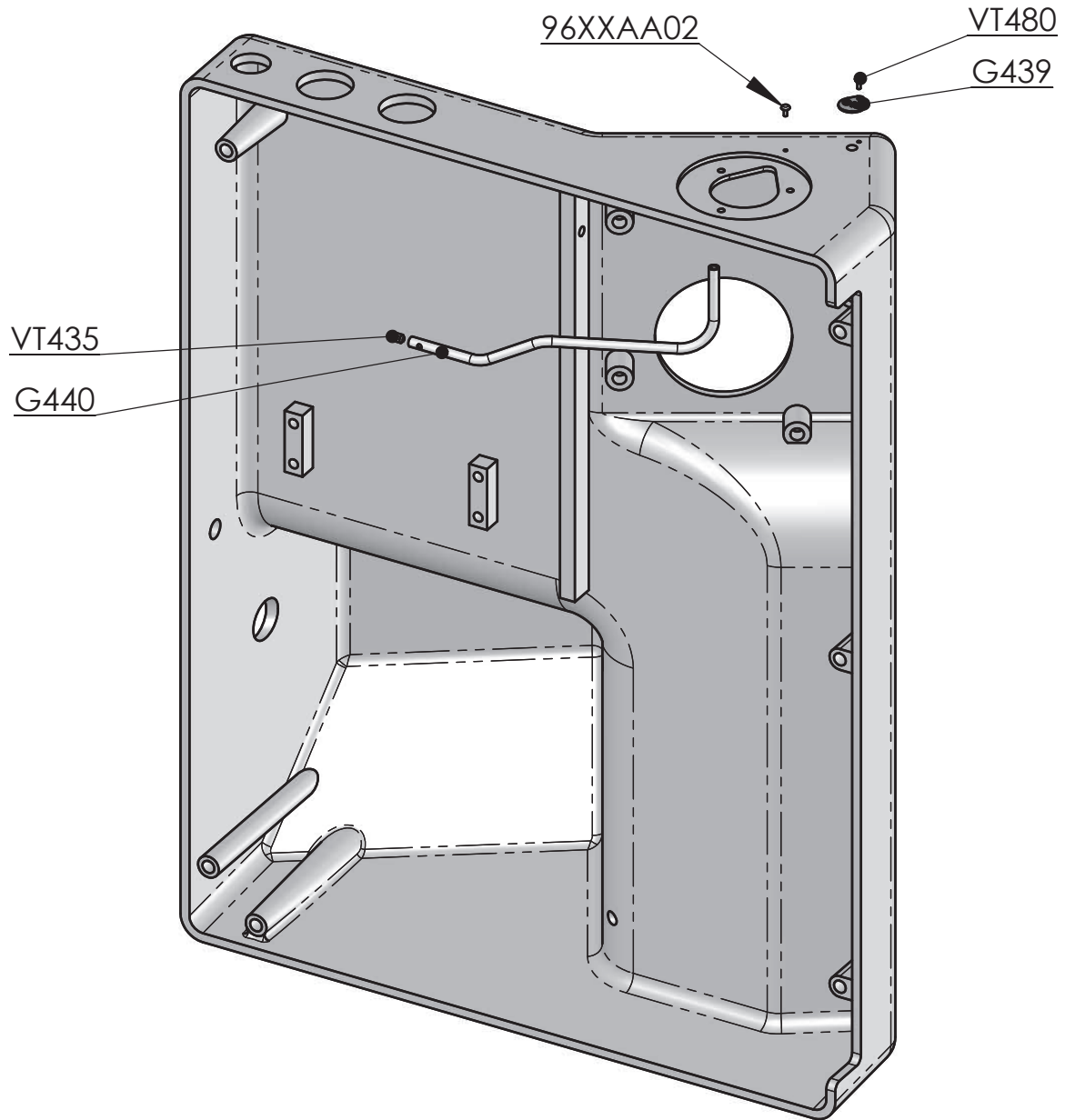

CODE	DESCRIPTION
96XXAA02	WHITE PLASTIC RIVET
G439	LABEL FOR LUBRIFICATION
G440	TUBE FOR LUBRIFICATION
VT 480	NAIL
VT 435	HEX SOCKET SET SCREW CUP POINT M5-0.8x5 SS

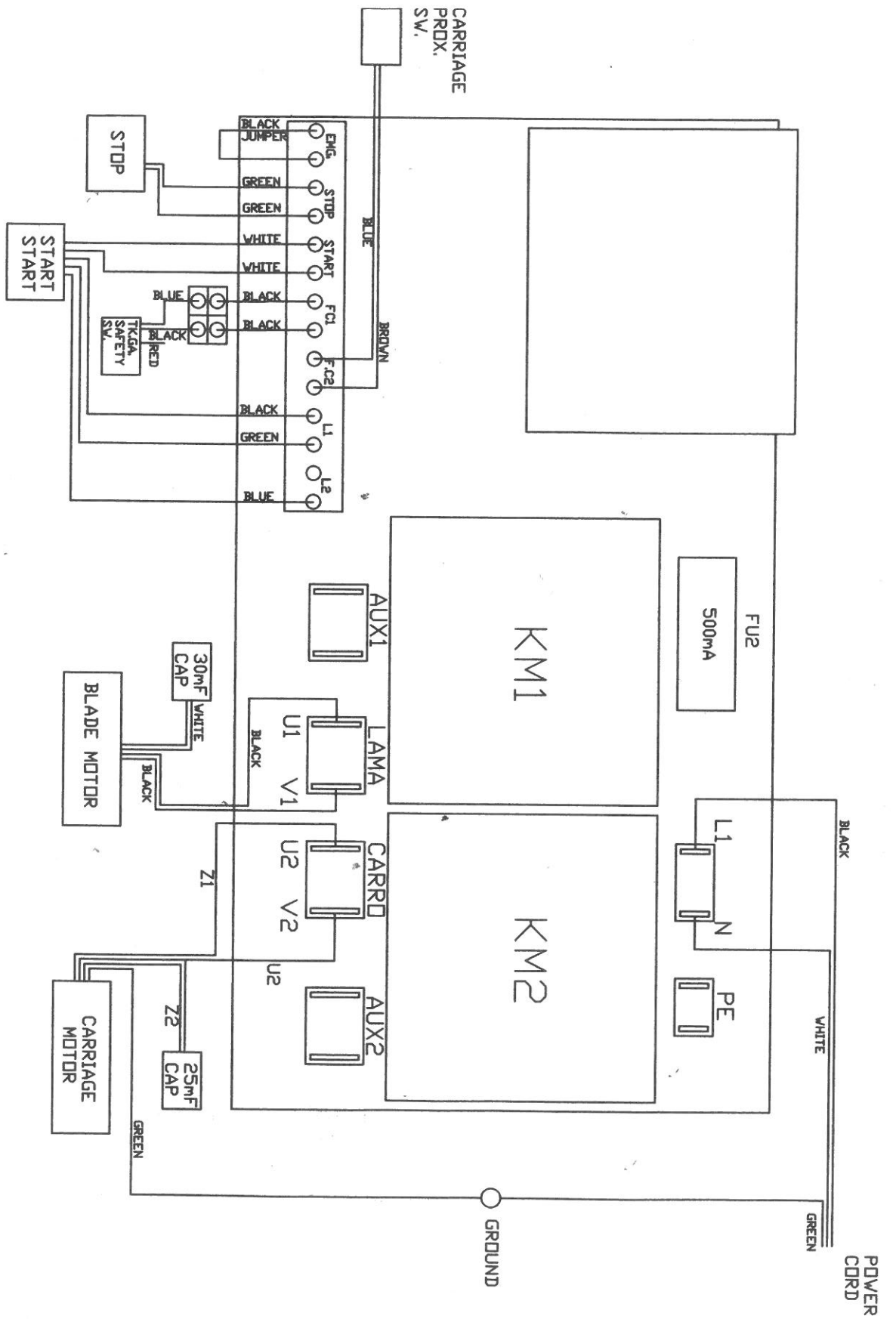



THE BIRO MANUFACTURING COMPANY  
1114 W. Main Street  
Marblehead, OH 43440 USA  
Ph. 419-798-4451 Fax 419-798-9106  
Email: [service@birosaw.com](mailto:service@birosaw.com)