



## MODEL AFMG-56-4 AUTOMATIC FEED MIXER GRINDER OPERATING AND SERVICE MANUAL



### IMPORTANT NOTICE

This Manual contains important safety instructions which must be strictly followed when using this equipment.

# TABLE OF CONTENTS

	Page
NOTICE TO OWNERS AND OPERATORS .....	1
SAFETY TIPS .....	2
INSTALLATION .....	3-5
UNCRATING AND SETUP .....	3
MOTOR WIRING AND ELECTRICAL REQUIREMENTS .....	4
MOTOR SPECIFICATIONS .....	4
OPERATION .....	6
TO PROCESS PRODUCT .....	6
CLEANING .....	7
MAINTENANCE .....	8
GRINDING BOWL INSTALLATION .....	8
MIXING PADDLE REMOVAL AND INSTALLATION .....	9
LUBRICATION .....	9-12
GEAR REDUCER LUBRICATION .....	10, 11
SPUR GEAR LUBRICATION .....	12
MIXER DRIVE GEAR ADJUSTMENT .....	12
AUGER DRIVE BELT TENSION .....	13
OPTIONAL PNEUMATIC FOOT SWITCH .....	13
PARTS DIAGRAMS .....	14-24
FRONT VIEW PARTS DIAGRAM .....	14
SIDE VIEW PARTS DIAGRAM .....	16
BACK VIEW PARTS DIAGRAM .....	18
MIXER DRIVE ASSEMBLY .....	20
LID HINGE COMPONENTS .....	21
JOURNAL BOX ASSEMBLY .....	22
PUSHBUTTON PLATE COMPONENTS .....	23
ELECTRICAL SUBPLATE COMPONENTS .....	24-25
WIRING DIAGRAM .....	26-27
TANDEM OPERATION ILLUSTRATIONS .....	28-29
SAFETY LABEL LOCATIONS .....	30
OPERATOR'S NOTES .....	31-32
OPERATOR'S SIGNATURE PAGE .....	33
LIMITED WARRANTY .....	34

# NOTICE TO OWNERS AND OPERATORS

**WARNING** to all purchasers, operators and operations supervisors: make certain every person who is to operate the **BIRO MODEL AFMG-56-4 MIXER GRINDER** has read this manual before attempting to operate machine. Have all operators sign the signature page found at the end of this manual.

BIRO's products are designed to process food products safely and efficiently. Unless the operator is properly trained and supervised, however, there is the possibility of a serious injury. It is the responsibility of the owner to assure that this machine is used properly and safely, strictly following the instructions contained in this Manual and any requirements of local law.

No one should use or service this machine without proper training and supervision. All operators should be thoroughly familiar with the procedures contained in this Manual. Even so, BIRO cannot anticipate every circumstance or environment in which its products will be used. You, the owner and operator, must remain alert to the hazards posed by the function of this equipment — particularly the **ROTATING GRINDING AUGER** and the **ROTATING MIXING PADDLE**, which can severely injure an inattentive operator amputating fingers and limbs. No one under eighteen (18) years of age should operate this equipment. If you are uncertain about a particular task, ask your supervisor.

This Manual contains a number of safe practices in the **SAFETY TIPS** section. Additional warnings are placed throughout the Manual. Warnings related to your personal safety are indicated by:



OR



Warnings related to possible damage to the equipment are indicated by:



BIRO also has provided warning labels on the equipment. If any warning label or Manual becomes misplaced, damaged, or illegible, please contact your nearest Distributor or BIRO directly for a replacement.

Remember, however, this Manual or the warning labels do not replace the need to be alert and to use your common sense when using this equipment.

– NOTE –

**“A copy of this manual is included with each MODEL AFMG-56-4  
AUTOMATIC FEED MIXER GRINDER.”**

**“The descriptions and illustrations contained in this manual  
are not binding. The manufacturer reserves the right to introduce any  
modification without updating the manual.”**

## SAFETY TIPS

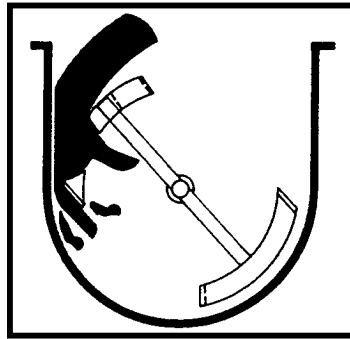

### ROTATING GRINDING AUGER & ROTATING MIXING PADDLE TO AVOID SERIOUS PERSONAL INJURY

- **NEVER** Touch This Machine without Training and Authorization by Your Supervisor.
- **DO NOT** Operate or Work Around This Machine with Loose Fitting Clothing. It Could Become Entangled in the Machine.
- **NEVER** Try to Manually Stop the Mixer. Always Wait Until the Machine has Completely Stopped Before Trying to Manipulate a Position Change.
- **NEVER** Place Hands into Machine Input or Output Openings.
- **NEVER** Run Machine with Guards Removed.
- **NEVER** Open Machine During Operation.
- **NEVER** Overload the Hopper.
- **ALWAYS** Keep Excessive Amounts of Water Away from the Control Panel.
- **ONLY** Use a Qualified Electrician to Install According to Local Building Codes: Machine **MUST** Be Properly Grounded.
- **ALWAYS** Connect to **Proper** Voltage & Phase.
- **ONLY** Install on Level, Non-Skid Surface in a Clean, Well-Lighted Work Area Away from Children and Visitors.
- **ALWAYS** Lock Machine Castors After Moving This Machine.
- **NEVER** Use This Machine For Non-Food Products.
- **NEVER** Operate Machine With Product Mixer Safety Cover Open or Removed or Magnetic Interlock Switch By-Passed. At Any Time an Operator Suspects that an Interlock or Safety Device is Not Functioning Properly, the Operation Should be Terminated, the Machine Unplugged and an Authorized Dealer Called to Inspect and Repair the Machine. Failure to Follow These Steps Could Result in Serious Personal Injury.
- **ALWAYS** Turn Off, Unplug Machine From Power Source and Perform Lockout/Tagout Procedure to this Machine **BEFORE** Attempting to Unjam or Unclog, Cleaning or Servicing
- **NEVER** Leave Machine Unattended While Operating.
- **NEVER** Alter This Machine From its Original Form as Shipped From Factory. **DO NOT** Operate Machine With Missing Parts.
- **PROMPTLY REPLACE** Any Worn or Illegible Warning Labels.
- **ALWAYS** Read Operation and Service Manual **BEFORE** Operating, Cleaning, or Servicing.
- **USE ONLY BIRO** Parts and Accessories Properly Installed.

# INSTALLATION



## TO AVOID SERIOUS PERSONAL INJURY, PROPERLY INSTALL EQUIPMENT IN ADEQUATE WORK AREA

- **ALWAYS** Use Qualified Technician and Electrician for Installation.
- **ALWAYS** Connect to **Proper** Voltage & Phase.
- **ALWAYS** Install Equipment in Work Area with Adequate Light and Space Away From Children and Visitors.
- **ONLY** Operate on a Solid, Level, Non-Skid Surface.
- **ALWAYS** Lock Machine Castors After Moving Machine to Operating Location.
- **NEVER** Bypass, Alter, or Modify This Equipment in Any Way From Its Original Condition.
- **NEVER** Operate With Product Mixer Safety Cover Opened or Removed or Magnetic Interlock Switch by-Passed.
- **NEVER** Operate Without all Warning Labels Attached and Owner/Operator Manual Available to the Operator.

## UNCRATING AND SET UP

1. Read this Manual thoroughly before installation and operation. **Do not** proceed with installation and operation if you have any questions or do not understand anything in this Manual. Contact your local Distributor, or BIRO first.
2. Remove all banding, shipping carton, and all equipment from inside the tub. Then take machine off shipping pallet.
3. This machine is shipped with the adjustable legs. The legs allow for a height adjustment from the floor to centerline of bowl 27 $\frac{7}{8}$ " minimum to 36 $\frac{7}{8}$ " maximum with standard foot assembly.
4. This machine weighs approximately 1700 pounds. To avoid accidents block up machine after raising to desired operating height.
5. The adjustable legs can be screwed in to lower the unit to the floor. **CAUTION, DO NOT** exceed 9" of exposed threaded leg, if more height is required, contact your local distributor.
6. Install machine on a level, non-skid surface in a well-lighted work area away from children and visitors.
7. This machine is complete except for knife and plate. There is a bowl shipping plug placed in the output end of the grinding bowl to retain the grinding auger during shipment. **REMOVE THE BOWL SHIPPING PLUG AND THE GRINDING AUGER.**



8. After checking and making sure the power supply is correct, plug in your machine. **NEVER OPERATE THIS MACHINE WITH PRODUCT MIXER SAFETY COVER OPEN OR REMOVED.** (Machine will not run with cover open.)
9. Machine must be properly grounded. Use qualified electrician to install according to local building codes.

## MOTOR WIRING AND ELECTRICAL REQUIREMENTS

1. Interchange of current is made in motor outlet box. Leads are properly marked. Changing instructions are on the motor plate or motor outlet box.
2. All grinders are wired 240 volts unless otherwise specified. Be sure motor specifications (voltage, cycle, phase) match power supply line. Be sure line voltage is up to specification.
3. Electrical connections to be in accordance with safety codes and National Electrical Code.
4. Rated voltage of the unit shall be identical with full supply voltage.
5. Voltage drop on the supply line shall not exceed 10% of full supply voltage.
6. The feederline conductor size in the raceway from the branch circuit to the unit must be correct to assure adequate voltage under heavy starting and short overload conditions.
7. The feederline conductor shall only be used for the supply of one unit of the relevant horsepower. For connections of more than one unit on the same feederline, a local electrician will have to be consulted to determine the proper conductor size.
8. The size of the electrical wiring required from the power source to the mixer grinder is a **MINIMUM OF No. 6 Ga. WIRE.**

200-230 Volt	6 Gauge Wire
380-480 Volt	8 Gauge Wire
575 Volt	10 Gauge Wire

9. The BIRO Manufacturing Company is not responsible for permanent wiring, connection or installation



**NOTE TO OWNER AND ELECTRICIAN: IF THIS MACHINE IS NOT CORD AND PLUG CONNECTED TO THE ELECTRICAL SUPPLY SOURCE, THEN IT SHOULD BE EQUIPPED WITH, OR CONNECTED TO, A LOCKABLE, MANUALLY-OPERATED DISCONNECT SWITCH (OSHA 1010.147).**

## MOTOR SPECIFICATIONS

### GRINDER MOTOR

HP	VOLTS	HZ	PH	AMPS
15	208	60	3	42.5
15	230	60	3	38.4
15	460	60	3	19.2
15	575	60	3	15
15	380	50	3	27.9

### MIXER MOTOR

HP	VOLTS	HZ	PH	AMPS
5	208	60	3	14.6
5	230	60	3	13.2
5	460	60	3	6.6
5	575	60	3	5.2
5	380	50	3	9.6

10. **Remove the auger** from bowl and hopper
11. Two sets of green and one red pushbuttons are located on the front of the machine that activate the magnetic contactors that control the mix and grind motors. The magnetic interlock switch is mounted in the motor compartment. When the safety cover is raised the machine will stop operation. **NOTE:** Before initial power is applied for start-up, the product mixer safety cover must be lifted slightly (5" to 6") and closed again before pushing the mixer start and/or grind start buttons.
12. Push the green start button for grind. **CHECK THE ROTATION OF THE AUGER DRIVE SHAFT; ROTATION MUST BE COUNTER-CLOCKWISE** as indicated by the rotation decal affixed to the grinding bowl. **ROTATION MUST ONLY BE CHECKED WITH THE GRINDING AUGER REMOVED**, otherwise serious irreparable damage may occur to grinding components. Rewire if necessary at the plug.
13. Push the green start button for mix. **CHECK ROTATION OF THE MIXING PADDLE; ROTATION MUST BE COUNTER-CLOCKWISE** as indicated by the rotation decal located on the paddle front mounting hub. Backwards operation will not allow mixing paddle to feed product to the grinding auger. Rewire if necessary at the plug.



14. If machine runs clockwise (backwards), it must be rewired to correct rotation, otherwise serious irreparable damage may occur to grinding components. Both the auger and the mixing paddle must operate in the same direction.
15. Insert auger assembly into grinding bowl, place knife (sharp edges out) onto the square end of the auger assembly. The breaker plate slides over the worm knife drive pin, and is held from rotating by pins in the grinding bowl. Install the retaining ring.



## **ONLY HAND TIGHTEN RETAINING RING**

For best results, use knife and plate as a set. **Do not operate machine for any period of time** without product in the grinding bowl. This will cause heating and dulling of the knife and plate.

16. Check placement of all warning labels and Manual. Machine is now ready for trained operators to process product.
17. Use meat deflector attached to grinding bowl to eliminate meat splatter.
18. Contact your local Distributor or BIRO directly if you have any questions or problems with the installation or operation of this machine.

# OPERATION



## **ROTATING GRINDING AUGER & ROTATING MIXING PADDLE TO AVOID SERIOUS PERSONAL INJURY**

- **ONLY** Properly Trained Personnel Should Use This Equipment.
- **NEVER** Place Hands Into Machine Input or Output Openings.
- **NEVER** Open Machine During Operation.
- **DO NOT** Wear Gloves While Operating.
- **DO NOT** Tamper With, Bypass, Alter, or Modify This Equipment in Any Way From Its Original Condition.
- **NEVER** Operate Machine With Product Mixer Safety Cover Opened or Removed or Magnetic Interlock Switch By-Passed. If for Any Reason the Hopper Cover or Safety Switches Require Adjustment or Replacement, Contact Your Local Authorized Distributor Immediately.
- **ALWAYS** Turn Off and Unplug Machine from Power Source and Perform Lockout/Tagout Procedure to This Machine Before Unjamming, Unclogging, Cleaning or Servicing.
- **NEVER** Leave Unattended While Operating.
- **NEVER** Operate Without All Warning Labels Attached and Owner/Operator Manual Available to the Operator.

### **A. TO PROCESS PRODUCT**

1. Before starting mixer grinder, have a container for receiving ground product at the output end of the grinding bowl.
2. **FIRST GRIND**
  - a. Fill Product Hopper (Maximum 400 Pounds), close Product Mixer Safety Cover. The paddle direction selector switch must be in the grind direction.
  - b. Push both grind and mix green start buttons to feed first grind. It is recommended to use a breaker plate with  $\frac{3}{8}$ " diameter or larger holes.
  - c. Push red stop button when all product has been ground out.
3. **SECOND GRIND**
  - a. Fill Product Hopper (Maximum 400 Pounds), close Product Mixer Safety Cover. If mixing is required the paddle direction selector switch must be in the mix position. Thorough mixing can be done by turning the paddle direction selector to mix and grind directions. During the mix operation seasonings may be added. The mix position will move product to the back hopper wall.
  - b. Push the mixer paddle green start button only and depending on product and the temperature push the red stop button after one to three minutes. Turn the paddle direction selector switch to the grind position and push the mixer green start button only, product will move to the front hopper wall, then push the red stop button and repeat by selecting the mix position or continue in the grind position.
  - c. Push the mixer paddle green start button and the auger green start button to feed first or second grind out.
  - d. Push red stop button when all product has been ground out.



## CLEANING



### **ROTATING GRINDING AUGER & ROTATING MIXING PADDLE TO AVOID SERIOUS PERSONAL INJURY**

- **ALWAYS** Turn Off, Unplug From Power Source and Perform Lockout/Tagout Procedures to This Machine **Before** Cleaning or Servicing.
- **ONLY** Use Recommended Cleaning Equipment, Materials, and Procedures.
- **NEVER** Spray Water or Other Liquid Substances Directly at Motor, Power Switch or any Other Electrical Components.
- **ALWAYS** Thoroughly Clean Equipment at Least Daily.

#### **CLEANING THE BIRO MIXER GRINDER**

1. Disconnect mixer grinder from power and air source and perform lockout/tagout procedures.
2. Remove grinding bowl end ring, breaker plate, knife and grinding auger.
3. Remove mixing paddles by first loosening the paddle lock set screw (located at the front of the machine). Then turn the locking lever clockwise approximately  $\frac{1}{4}$  turn to unlock the paddle shafts and remove them from the hopper.



### **DO NOT POWER SPRAY DIRECTLY AT ELECTRICAL COMPONENTS**

4. Machine is now ready to be cleaned using warm soapy water and rinsed with clean water. Machine may be cleaned by power spray washing, taking care to not spray directly at any electrical controls.
5. The grinding head can be removed for cleaning if desired. This is accomplished by removing the three nuts on the back flange of the grinding head.
6. After machine has been cleaned and allowed to air dry, all exposed metal surfaces should be coated with a good food grade light oil or grease.

## MAINTENANCE



### **ROTATING GRINDING AUGER & ROTATING MIXING PADDLE TO AVOID SERIOUS PERSONAL INJURY**

- **ALWAYS** Turn Off, Unplug from Power Source and Perform Lockout/Tagout Procedures to This Machine **BEFORE** Servicing.
- **NEVER** Touch This Machine Without Training and Authorization By Your Supervisor
- **NEVER** Place Hands Into Machine Input or Output Openings.
- **NEVER** Bypass, Alter or Modify This Equipment in Any Way From Its Original Condition.
- **PROMPTLY REPLACE** Any Worn or Illegible Warning Labels.
- **USE ONLY GENUINE BIRO** Parts and Accessories Properly Installed.

#### **A. GRINDING BOWL INSTALLATION**

1. Mount the grinding bowl on the three threaded studs on the front of the machine. Tighten in position with provided nuts.
2. Place the grinding auger in the grinding bowl and fully seat rear drive tang into auger drive shaft.
3. Install knife, breaker plate and end retaining ring.



#### **ONLY HAND TIGHTEN RETAINING RING**

4. When the bowl assembly is mounted and tight, there should be approximately  $\frac{1}{8}$ " gap between the back inside wall of the grinding trough and the back of the auger. The bowl ring wrench which is provided with each mixer grinder is used only for **REMOVAL** of the end retaining ring for cleaning purposes or for changing knife and breaker plate.

## B. MIXER PADDLE REMOVAL AND INSTALLATION

1. The BIRO MODEL AFMG-56-4 mixer paddles are timed to allow for proper mixing action.

### 2. PADDLE REMOVAL:

Remove mixing paddles by first loosening the paddle lock set screw (located at the front of the machine). Then turn the locking lever clockwise approximately  $\frac{1}{4}$  turn to unlock the paddle shafts. Remove paddle shafts by first sliding them towards the front of the machine and then lifting them out of the hopper.

### 3. PADDLE INSTALLATION:

The mixing paddles will only fit on its corresponding drive hub. To install paddle shafts first insert the drive end of the paddle shaft into or onto the drive hub and slide toward the back hopper wall. Then insert the lock arm assembly turning the lock arm into place and finally tightening the paddle lock set screw.

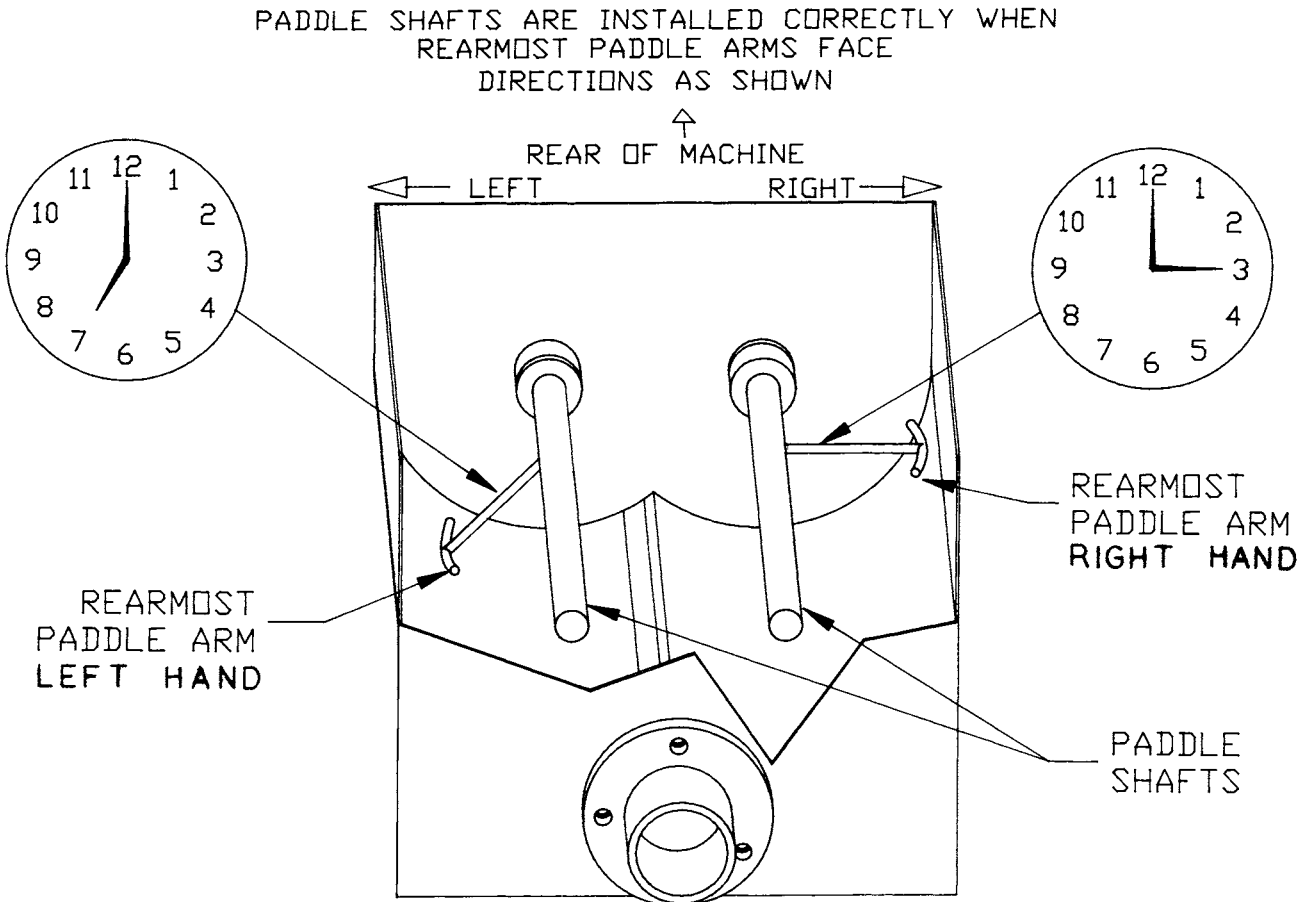

## C. LUBRICATION

1. **MOTORS:** The mix and grind motors have pre-lubricated bearings. These bearings should be re-lubricated annually with a good grade of bearing grease. Do not over-grease.
2. **BEARING HOUSING:** The main bearings are housed in an enclosed and sealed journal box. Re-lubricate semi-annually with a good grade of bearing grease. Do not over-grease. This may cause seal damage.

## No. 60027 GEAR REDUCER LUBRICATION AND MAINTENANCE

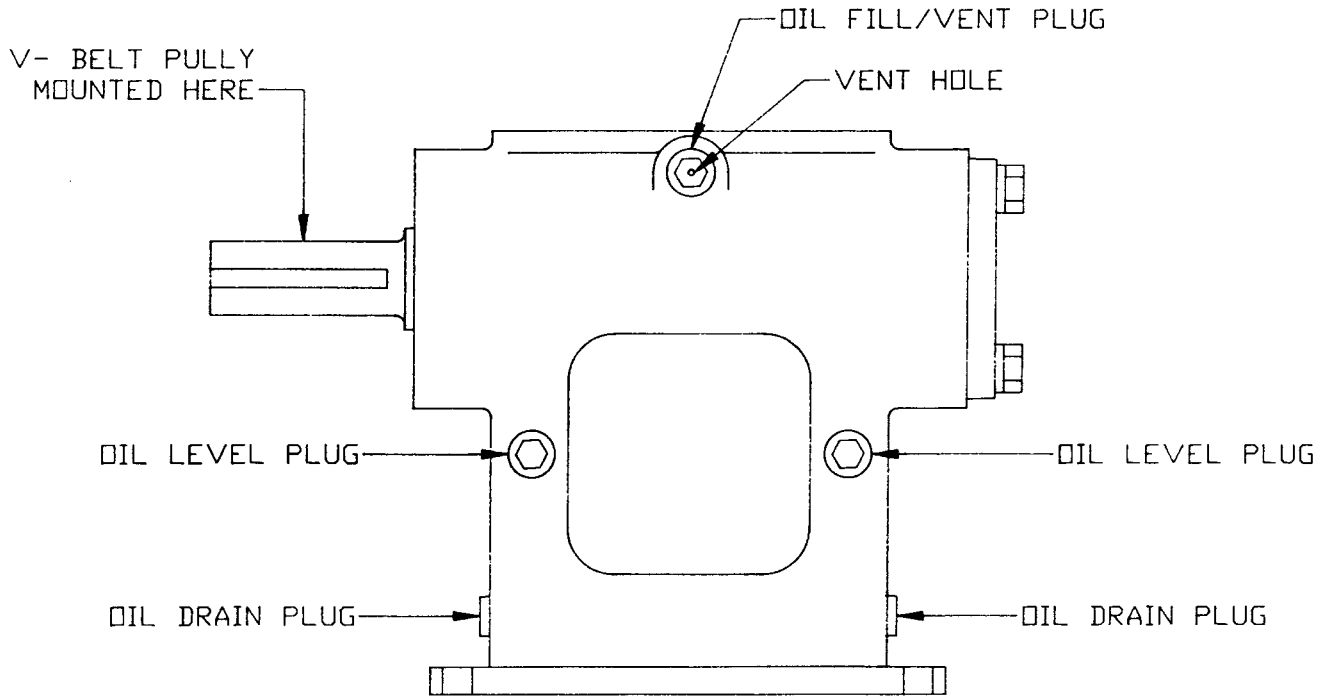

**VIEW IS FROM OPPOSITE SIDE OF DRIVEN SHAFT**

### LUBRICANTS FOR WORM GEAR REDUCERS

The precision-made gears and bearings in Speed Reducers require high-grade lubricants of the proper viscosity to maintain trouble-free performance. For best results, use lubricants on the following chart for worm gear reducers.

	MINERAL OILS	SYNTHETIC OILS
Ambient Temperature	16 to 50°F	96 to 131°F
Final State Worm Speed	Up to 2000 FPM	Up to 450 FPM
ISO Viscosity Grade	460	680
AGMA Lubricant No.	#7 Compounded	8 S

Mobil	600W Super Cylinder	SHC 636
American Lubricants	AGMA #7 Gear Oil	N/A
Castrol	Tribol 1105-7C	Tribol 800/680
Chevron	Cylinder Oil W460	Tregre 680
Conoco	Inca Oil 460	N/A
Exxon (Esso)	Spartan EP 460	Teresstic SHP 680
Fiske Brothers	SPO-277	N/A
Shell	Valvata J 460	Omala RL 680
Texaco	Vanguard 460	Pinnacle 680

**Standard factory-installed lubricant is Mobile Oil Corp. 600 W Super Cylinder Oil (AGMA7).**

Some gear lubricants contain E.P. additives that can be corrosive to gear bronze material. Avoid lubricants that are compounded with sulfur and/or chlorine.

Lubricant selections are provided by the lubricant manufacturer based on AGMA recommended viscosity grades. Viscosity grades are based on Lubrication Standard ANSI/AGMA 9005-D94.

# LUBRICATION (Cont.)

## 1. Factory Filling

The speed reducers are oil filled at the factory with Mobil 600W Super Cylinder Oil to the proper level for the standard mounting position. **The oil level should be checked and adjusted (if necessary) prior to operation, using the oil level plug provided and while the unit is oriented in its operating position.**

## 2. Oil Changing

When changing oil for any reason, it should be remembered that oils of various types may not be compatible. Therefore, when changing to a different oil, it is recommended that the housing be completely drained and thoroughly flushed with a light flushing oil prior to refilling with the appropriate lubricant. The oil level should be rechecked after a short period of operation and adjusted, if necessary.

### A. Initial Oil Change

Oil in the mixer transmission should be changed after the first four (4) weeks of operation. This is to remove the initial oil and also any small metal shavings that may have been generated during the mating of the gears

### B. Subsequent Oil Changes

After the initial oil change, subsequent changes should be performed every six (6) months. After draining the oil, refill the unit to the "level" plug on the side of the transmission with Mobil 600W Super Cylinder oil or equivalent.

### C. Synthetic Oils

Synthetic lubricants can be advantageous over mineral oils in that they generally are more stable, have a longer life, and operate over a wider temperature range. These oils are appropriate for any application but are especially useful when units are subjected to low start-up temperatures or high operating temperatures. However, continuous operation above 225°F may cause damage to seals or other components. It is recommended that the initial oil be changed or filtered after the first 1500 hours of operation to remove metal particles that accumulate during break-in. Subsequent oil changes should be made after 5000 hours operation if the units are operating in a clean environment. This can be extended to 10,000 hours if using new reformulated Mobil SHC 636 lubricants (orange in color) and the lubricant remains free of contamination over this period.

## 3. PROCEDURE FOR REPLACING OIL IN MIXER TRANSMISSION

- a. Unplug mixer grinder from power source and perform lockout/tagout procedures.
- b. Remove rear drive or access cover.
- c. Remove vent plug on the top side of the gearbox and the oil level plug from the side of the gearbox.
- d. With a container in place to catch old oil, remove the lower drain plug on the side of the gearbox.
- e. When all oil has drained, clean the drain plug and re-install in the gearbox.
- f. Refill the gearbox with Mobil 600W Super Cylinder oil or equivalent until oil appears at the bottom of the oil level hole. Approximately 3.1 pints of oil.
- g. Replace oil level and vent plugs.
- h. Reinstall rear drive cover or access cover.

## 4. Overfilling or Underfilling

If a speed reducer is overfilled with oil, the energy used in churning the excessive oil can result in overheating. If this occurs, shut down the drive, remove the oil level plug and allow oil to drain until oil ceases to drain from the level hole, reinstall the oil level plug and restart the drive. If the speed reducer is underfilled, the resultant friction can cause overheating and possible damage. If this occurs, fill the speed reducer to the oil level plug hole and check the gearing for excessive wear.

## 5. Oil Seals

Although the speed reducer uses high quality oil seals and precision ground shafts to provide a superior seal contact surface, it is possible that circumstances beyond the speed reducer's control can cause oil seal leakage (damage during shipment or installation, etc.). When replacing a shaft oil seal, using the following suggestions will help to insure leak-free operation and long seal life.

- A. When installing a new seal, cover the keyway and any other surface discontinuity with smooth tape to protect the seal lip from being damaged.
- B. A sealant should be used between the O.D. of the seal and the I.D. of the bore into which the seal is installed. The seal bore should also be free of any burrs, nicks, or scratches.
- C. Be sure that the seal is not cocked in the seal bore. The outer face of the seal should be flush with the surface into which it is mounted.

## D. SPUR GEARS LUBRICATION

Gears should be checked after the first two weeks of operation. Then every 6 weeks, depending on hour's used or severe duty every 2 weeks. Recommended types of spur gear lubricant are those with Lithium soap base. Also bonded lubricants such as Shell Cassida EPS Grease 2 or equivalent for Spur Gears. The lubricant should be of a viscosity whereby it will stick and bond to the working surfaces to reduce heat and wear to the Spur Gear Teeth.

- a. Unplug mixer grinder from power source and perform lockout/tagout procedures.
- b. Remove rear drive cover or access cover.
- c. Spray or brush lubricant on teeth of the Spur Gears complete.
- d. Reinstall rear drive cover.

## E. MIXER DRIVE GEAR ADJUSTMENT

Unplug mixer/grinder from power source and perform lockout/tagout procedures.

Remove rear drive cover.

Loosen the four bolts and adjustment bolt holding the 5 hp motor and transmission to its mounting plate.

Slide Mixer Transmission to the right.

When the Spur Gears are interlocked leave a little clearance, about  $\frac{1}{64}$ " -  $\frac{1}{32}$ ".

**Do Not Bottom Out the Gear Teeth into the Other Driven Gear.**

This will put excessive and damaging pressure on the transmission bearings and mixer drive shaft bearings. Check with a straight edge from the large spur gear across the face to the face of drive spur gear in two different locations. The spur gears must be aligned. Tighten the adjustment bolt up to the transmission and tighten jam nut. Tighten the four bolts to the transmission and mounting plate. Check the spur gear alignment again. See Lubrication.

Reinstall rear drive cover.

— NOTES —

## F. AUGER DRIVE BELT TENSION

1. Unplug mixer/grinder from power source and perform lockout/tagout procedures.
2. Remove rear drive cover and motor cover for adjusting belt tension.
3. The Eagle Pd belt should be checked after the first 16 hours of use. Recheck the belt tension and the sprocket alignment. Check again every 6 weeks.
4. The Eagle Pd belt total deflection is  $\frac{13}{64}$ ". The sprocket must be aligned. Check with a straight edge across the face of the sprockets.

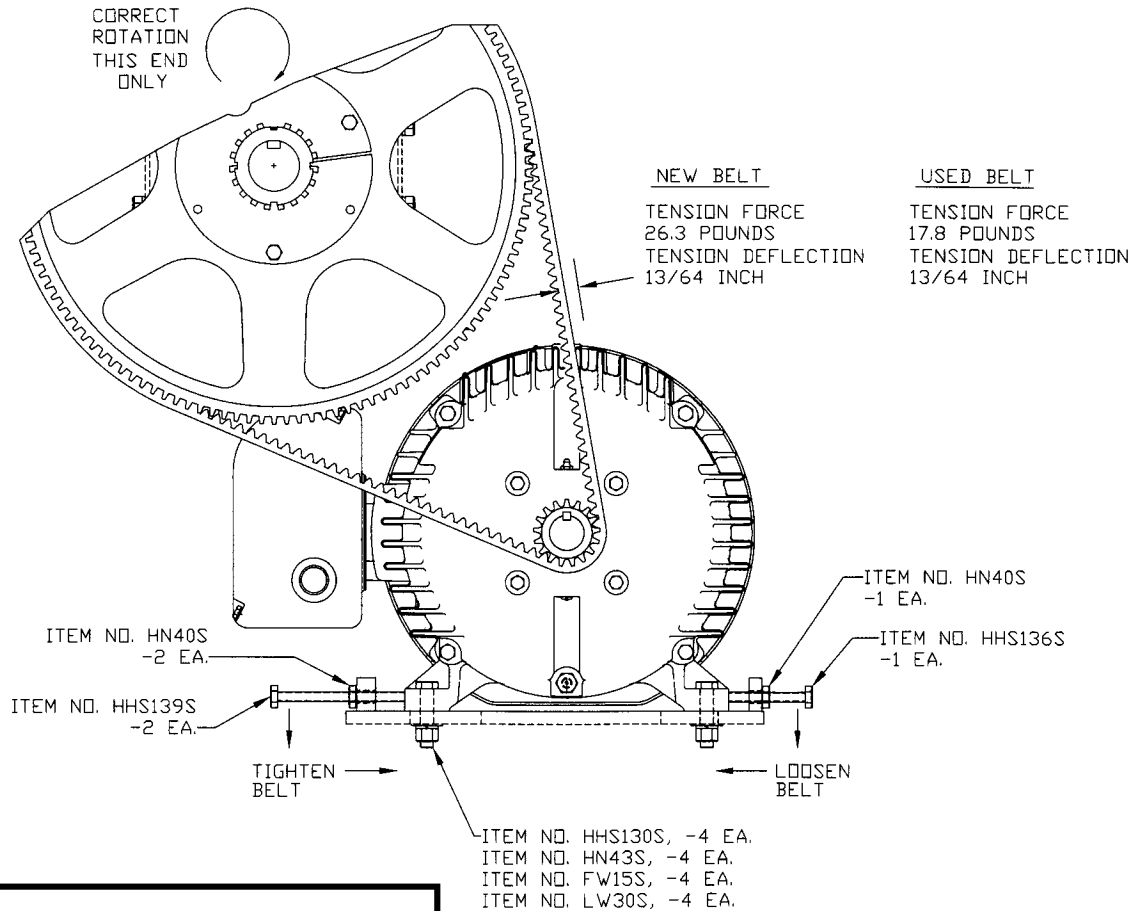

## OPTIONAL PNEUMATIC FOOT SWITCH

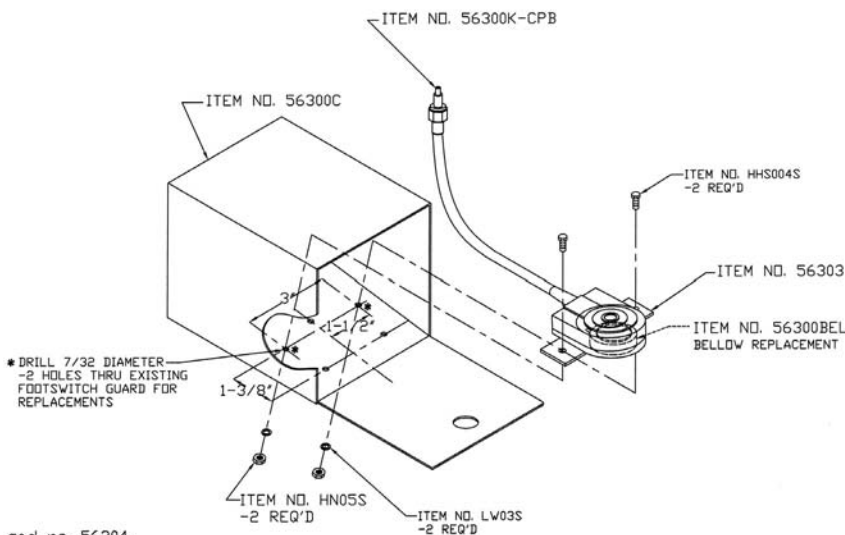

PART NO.	PART NAME/DESCRIPTION
56300K-CPB	Coupling Insert, Male
56304	Foot Switch Assy w/6' Tube & Guard
56303	Foot Switch Only
56300C	Guard Only
HHS004S	Hex Head Screw 8-32 x $\frac{3}{8}$ S.S.
LW05S	Lock Washer #10 S.S.
HN10S	Hex Nut 10-32 S.S.

cad no. 56304

# AFMG-56-4 FRONT VIEW PARTS DIAGRAM

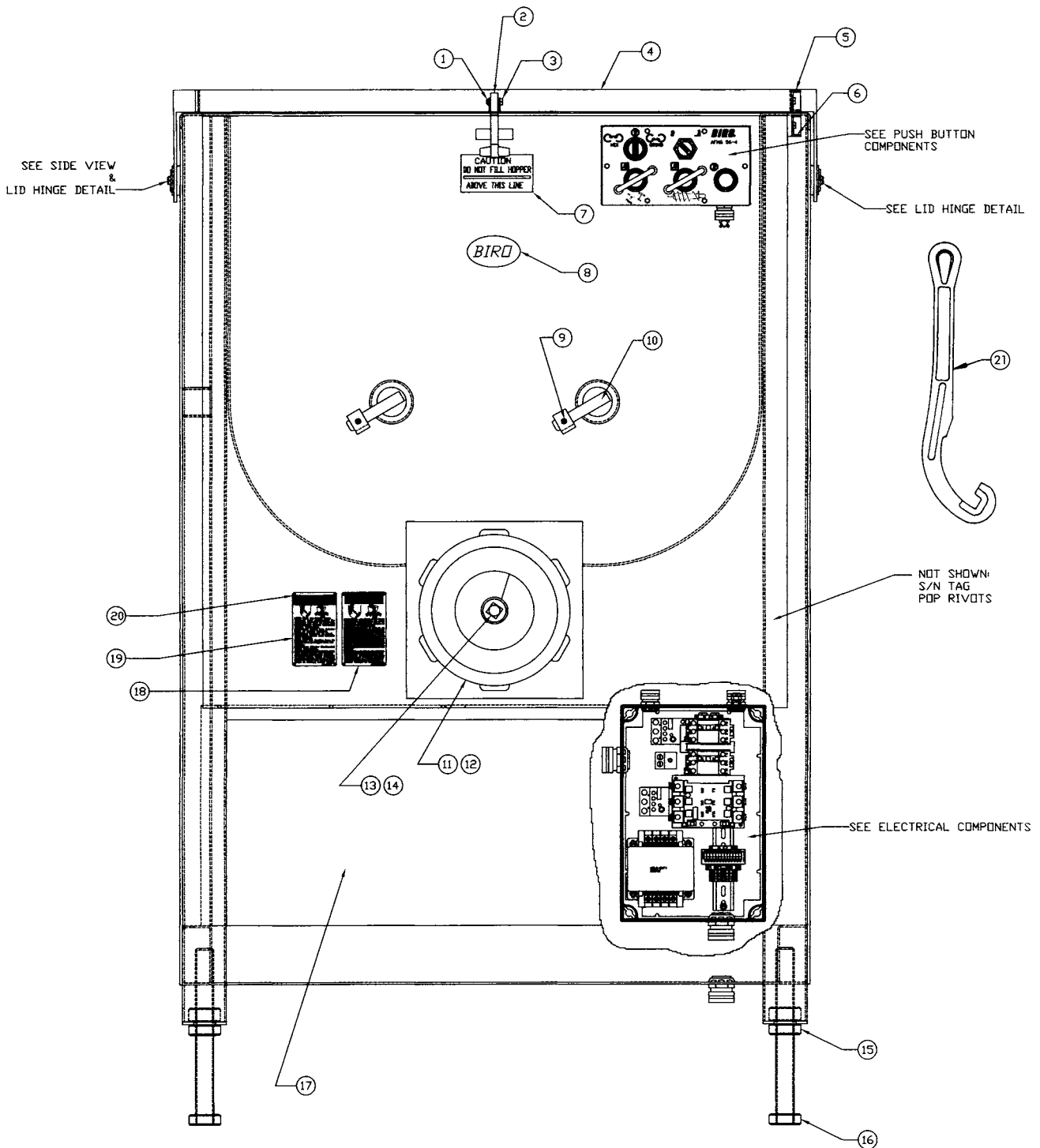



## AFMG-56-4 FRONT VIEW PARTS LIST

Fig.	Item No.	Description
1	HHS040S	1/4-20 x 3/4 hex head screw
2	EMG62102	Safety cover latch
3	HNN16S	1/4-20 hex nut – SS – Nylok
4	40414	Safety cover, 400 lb. hopper
5	60072	Safety switch magnet
6	PC168	Safety switch
7	53687	Decal, Do Not Fill Above This Line
8	VTS7181	Biro world decal
9	53568	Mixer paddle lock screw (2 req'd.)
10	53852-1	Lock arm assembly (2 req'd.)
11	52353-S	Bowl w/plate pins, SS
12	HR56-S	Ring, SS
13	HK52/56	Knife drive pin
14	52556	Auger assembly, fabricated, SS
15	HN68S	1 1/4-7 hex nut, S.S. (4 req'd.)
16	60045	Foot assembly, 12 in. long (4 req'd.)
17	40416-1	Cover, auger motor (S/N 456102 on)
18	H653-SP	Grinder warning label, Spanish
19	H653-E	Grinder warning label, English
20	375	Drive screws (8 req'd.)
21	52357	Ring wrench (order H340)
22	40454	Paddle assembly – left hand – male
23	40453	Paddle assembly – right hand – female

### NOT SHOWN

VT460S  
375

Model & serial no. plate  
Drive screws (4 req'd.)

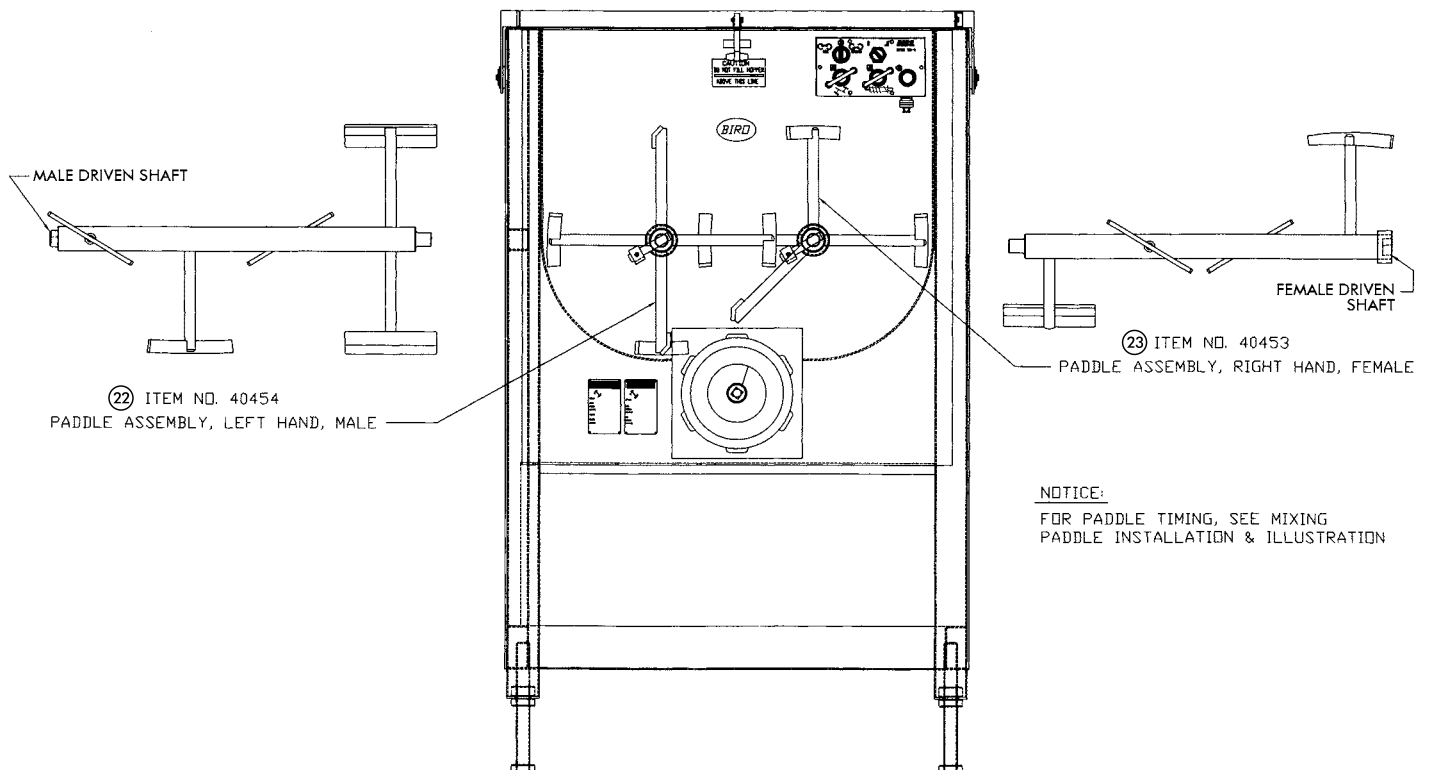

# AFMG-56-4 SIDE VIEW PARTS DIAGRAM

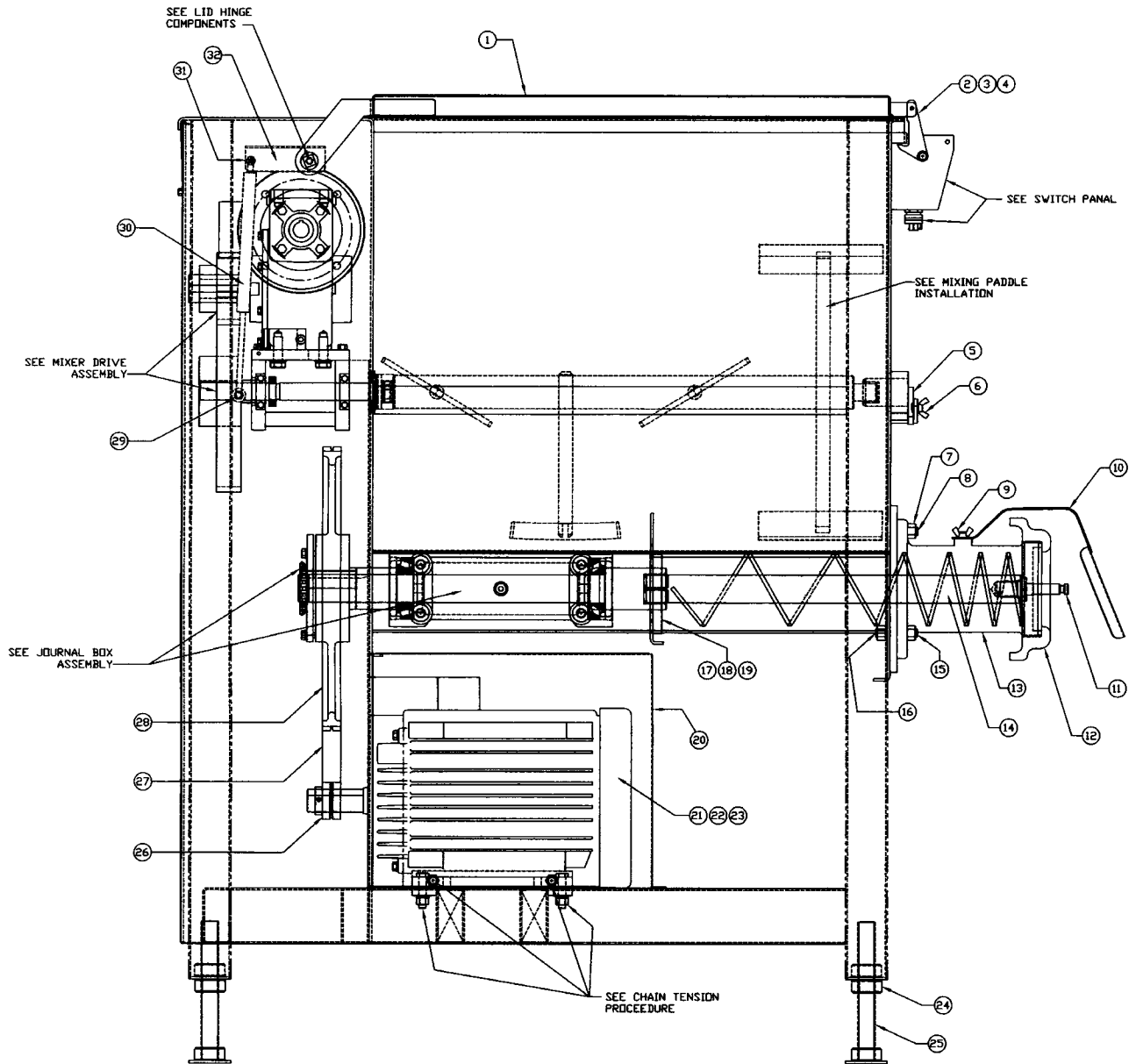

## AFMG-56-4 SIDE VIEW PARTS LIST

Fig.	Item No.	Description
1	40414	Safety cover, 400 lb. hopper
2	56072	Safety cover latch
3	HHS040S	1/4-20 x 3/4 hex head screw
4	AN15S	1/4-20 acorn nut
5	53852	Mixer paddle lock arm assembly
6	53568	Mixer paddle lock set screw
7	HN64	3/4-10 hex nut, zinc plated (3 req'd.)
8	52351	Front plate stud, 3/4-10 x 2 1/8 (1 req'd.)
9	WN20S	3/8-16 wing nut, S.S.
10	52392	Meat guard splash shield
11	HK52/56	Knife drive pin
12	HR56-S	Ring, SS
13	52353-S	Bowl w/plate pin, SS
14	52556	Auger assembly, fabricated, SS
15	52351-1	Front plate stud, 3/4-10 x 3.00 (2 req'd.)
16	HN64	3/4-10 hex nut zinc plated (2 req'd.)
17	52598	Auger drive shaft seal
18	60008	Seal retainer
19	FHS26S	10-32 x 3/4 flat head screw, S.S., (4 req'd)
20	40416-1	Cover, auger motor (S/N 456102 on)
21	65202	Motor, 15HP, 230/460V/60HZ/3Ph
22	65202-200	Motor, 15HP, 200V/60HZ/3Ph
23	65202-575	Motor, 15HP, 575V/60HZ/3Ph
24	HN68S	1 1/4-7 hex nut, S.S. (4 req'd.)
25	60045	Foot assembly, 12 in. long (4 req'd.)
26	40429	Sprocket, 30 teeth
27	40428	Drive belt, 250 teeth
28	40430	Sprocket, 224 teeth
29	EMG62062-1	Ball stud, gas spring
30	EMG62190	Gas spring, internal
31	EMG62062-1	Ball stud, gas spring
32	40444	Lid damper arm, right hand

# AFMG-56-4 BACK VIEW PARTS DIAGRAM

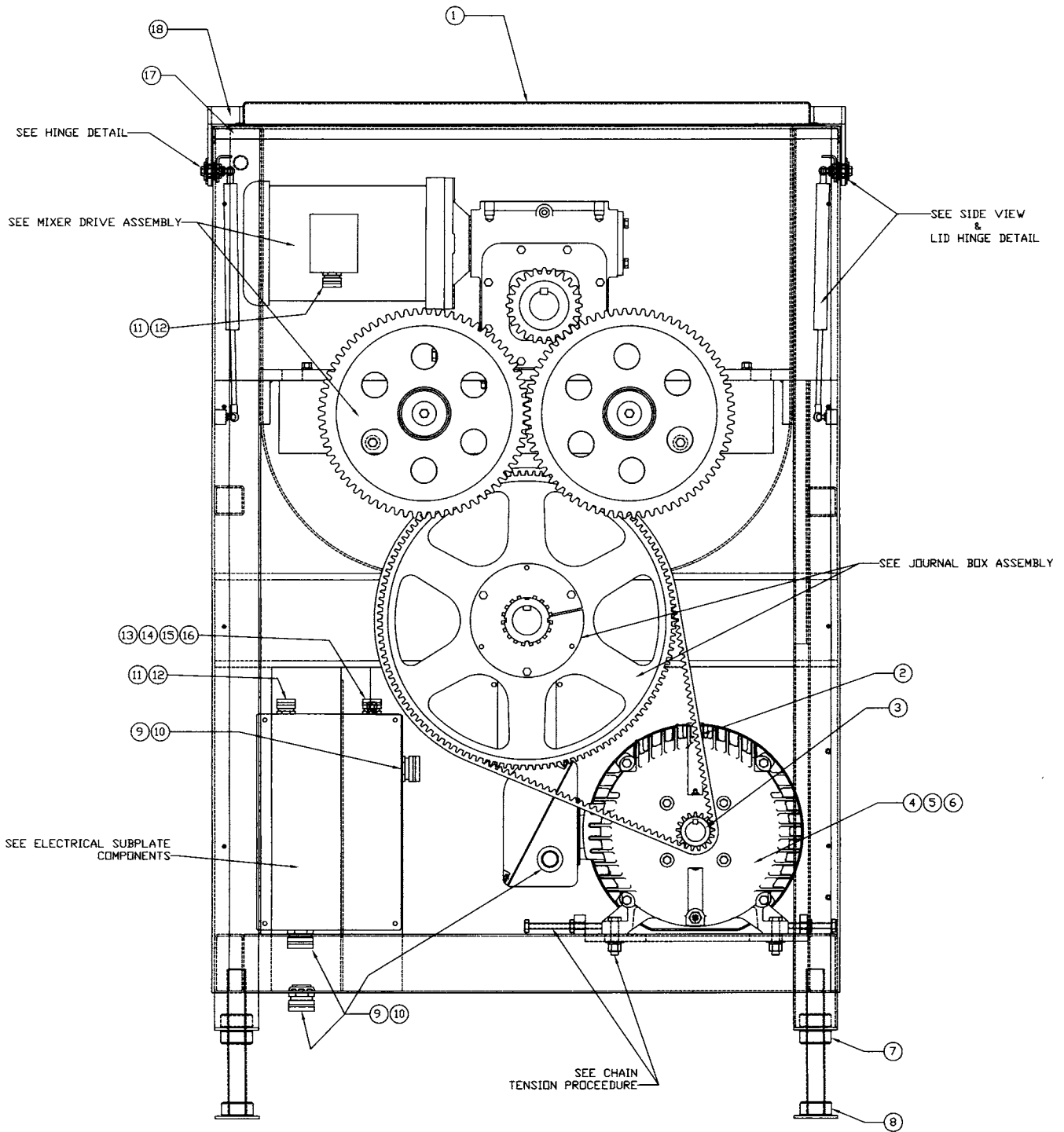

## AFMG-56-4 BACK VIEW PARTS LIST

Fig.	Item No.	Description
1	40414	Safety cover, 400 lb. hopper
2	40428	Drive belt, 250 teeth
3	40429	Sprocket, 30 teeth
4	65202	Motor, 15HP, 230/460V/60HZ/3Ph
5	65202-200	Motor, 15HP, 200V/60HZ/3Ph
6	65202-575	Motor, 15HP, 575V/60HZ/3Ph
7	HN68S	1 $\frac{1}{4}$ -7 hex nut, S.S. (4 req'd.)
8	60045	Foot assembly, 12 in. long (4 req'd.)
9	224-17	Cord grip connector, 1 $\frac{1}{4}$ , 1.00-1.125
10	224-17N	Lock nut, strain relief, 1 $\frac{1}{4}$
11	224-4	Cord grip connector, $\frac{1}{2}$ , .625-.75
12	224-1N	Lock nut, conduit connector, $\frac{1}{2}$ "
13	224-6	Cord grip connector, $\frac{1}{2}$ , .375-.500
14	224-1N	Lock nut, conduit connector, $\frac{1}{2}$ "
15	BES16993	Strain relief fitting, PG7
16	BES16994	Lock nut, PG7
17	PC168	Safety switch
18	60072	Safety switch magnet

## AFMG-56-4 MIXER DRIVE ASSEMBLY

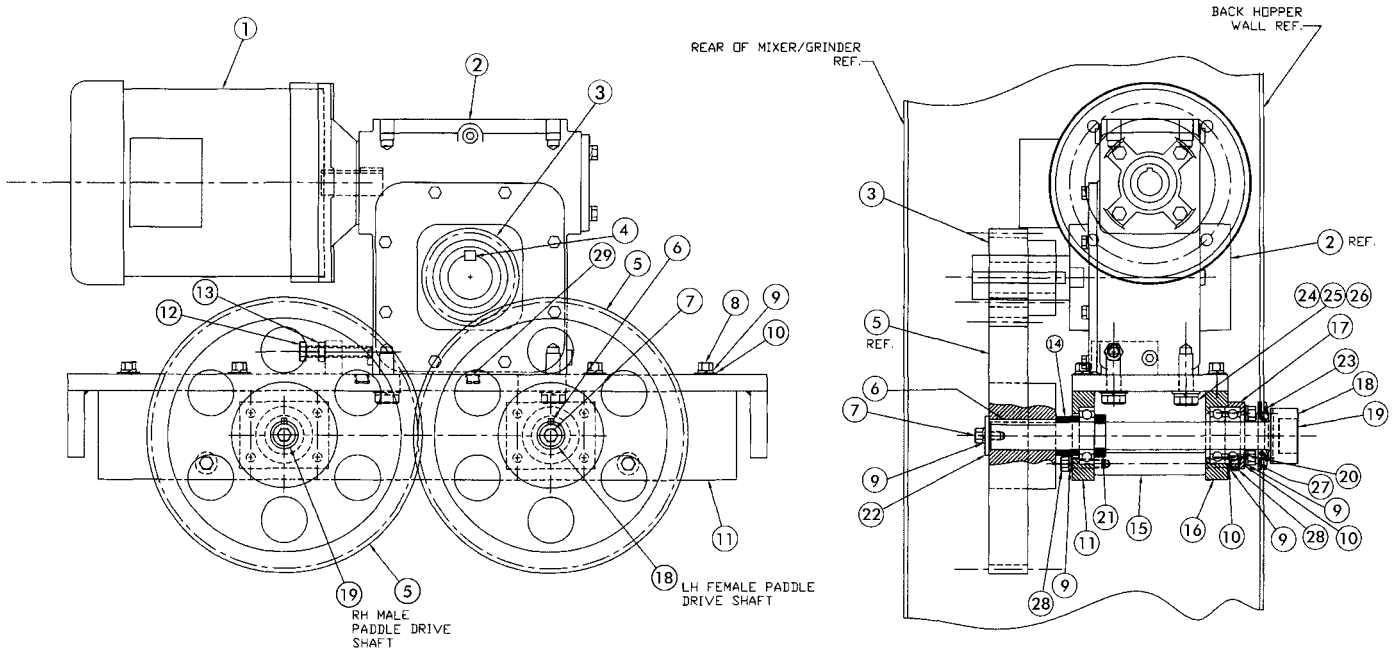

Fig.	Item No.	Description
1	60028	Mixer motor, 5HP-208-230/460V, 3PH, 60Hz
2	60027	Mixer transmission, 25:1 ratio
3	40425	Drive gear, 20 tooth spur gear
4	52413	Key, mixer drive gear – 1/2 sq. x 3
5	40426	Driven gear, 60 tooth spur gear
6	60030	Key, mixer driven sprocket
7	HHS067S	Hex head cap screw, 3/8-16 UNC x 3/4" stn stl
8	HHS083S	Hex head cap screw, 3/8-16 UNC x 1 3/4" stn stl
9	LW20S	Lock washer, 3/8 stn stl
10	FW07S	Flat washer, 3/8 stn stl
11	40433	Bearing mounting plate rear, paddle drive shaft
12	HHS136S	Hex head cap screw, 1/2-13 UNC x 3" stn stl
13	HN42S	Hex nut, 1/2-13 UNC stn stl
14	60043	Spacer, driven spur gear
15	60041	Spacer, paddle drive shaft brg mnt plate
16	40432	Bearing mounting plate front, paddle drive shaft
17	60024	Cap, front bearing mtg plate
18	60047	Paddle drive shaft, LH female
19	60048	Paddle drive shaft, RH male
20	60054	Bearing, 1 1/4 bore single row ball bearing
21	60042	Locking collar, 2pcs
22	60050	Washer, paddle drive shaft
23	53953	Seal, mixer drive shaft
24	HHS147S	Hex head cap screw, 5/8-11 UNC x 2" stn stl
25	LW35S	Lock washer, 5/8 stn stl
26	FW17S	Flat washer, 5/8 stn stl
27	HHS083S	Hex head cap screw, 3/8-16 UNC x 1 3/4" stn stl
28	HHS080S	Hex head cap screw, 3/8-16 UNC x 1 1/2" stn stl
29	SHS080S	Socket head cap screw, 3/8-16 UNC x 1 1/2" stn stl

# LID HINGE COMPONENTS

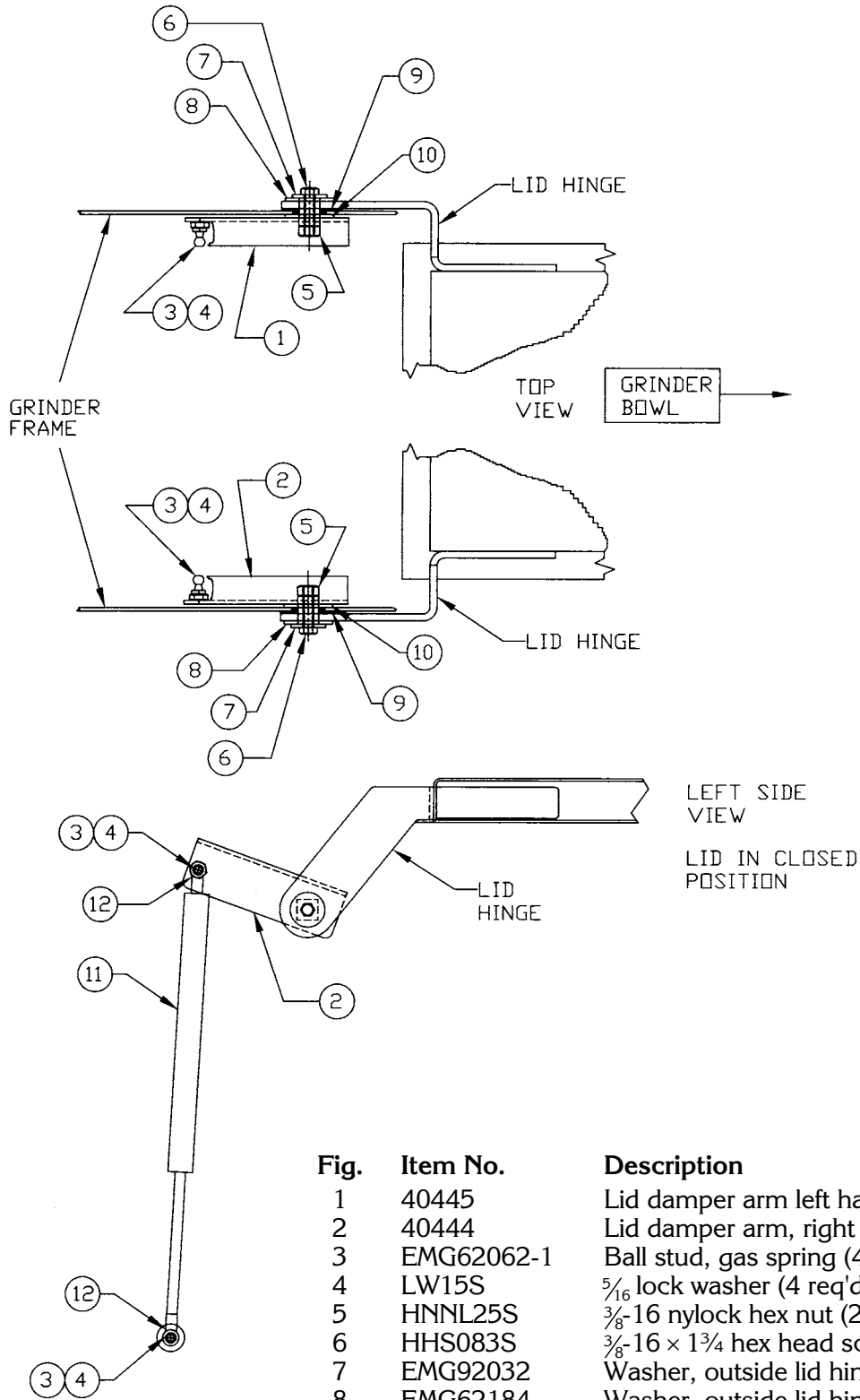

Fig.	Item No.	Description
1	40445	Lid damper arm left hand
2	40444	Lid damper arm, right hand
3	EMG62062-1	Ball stud, gas spring (4 req'd.)
4	LW15S	$\frac{5}{16}$ lock washer (4 req'd.)
5	HNNL25S	$\frac{3}{8}$ -16 nylock hex nut (2 req'd.)
6	HHS083S	$\frac{3}{8}$ -16 $\times$ 1 $\frac{3}{4}$ hex head screw (2 req'd.)
7	EMG92032	Washer, outside lid hinge arm (2 req'd.)
8	EMG62184	Washer, outside lid hinge arm (2 req'd.)
9	EMG62182	Sleeve bushing, hinge (2 req'd.)
10	EMG62181	Washer, inside lid hinge (2 req'd.)
11	EMG62190	Gas spring, internal (2 req'd.)
12	EMG62190-1	Retaining clip – gas spring – internal (4 req'd.)

**NO. 40466**  
**JOURNAL BOX ASSEMBLY**  
**WITHOUT SPROCKET**

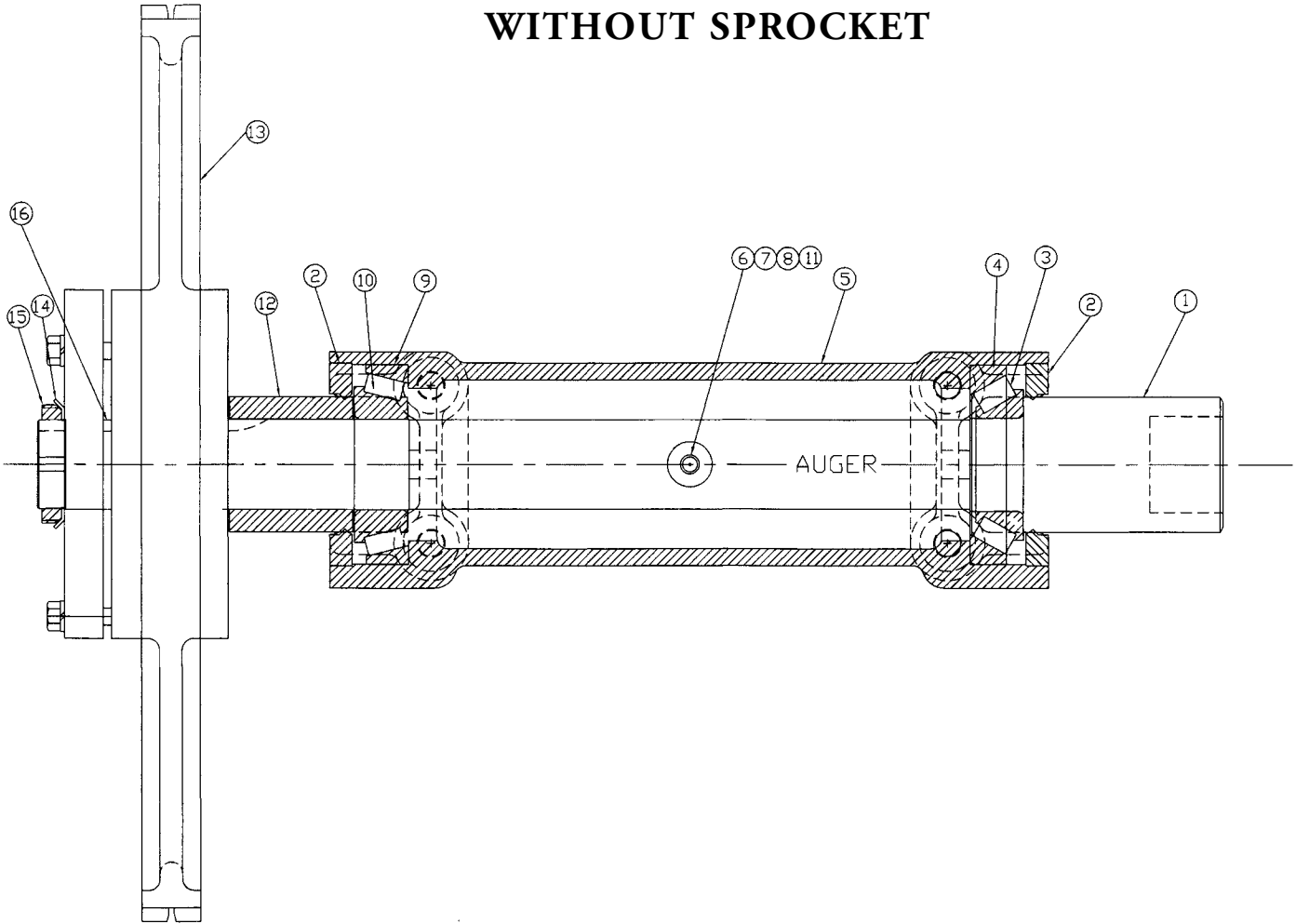

Fig.	Item No.	Description
	40466	Journal Box Assembly w/out Sprocket
1	52527	Auger drive shaft
2	52505	Grease seal
3	52507	Bearing cone
4	52506	Bearing cup
5	52502	Journal box
6	360A1	Grease fitting
7	60059	Coupling, $\frac{1}{8}$ " NPT
8	60060	Nipple, $\frac{1}{8}$ " NPT $\times$ 3"
9	52508	Bearing cup
10	52509	Bearing cone
11	60061	Nipple w/vent, $\frac{1}{8}$ " $\times$ 3"
12	40437	Spacer, journal box
13	40430	Sprocket, W224S, 224 tooth (Eagle Belt Drive)
14	52511	Bearing lock washer
15	52510	Bearing lock nut
16	52413	Key



## AFMG-56-4 PUSHBUTTON PLATE COMPONENTS

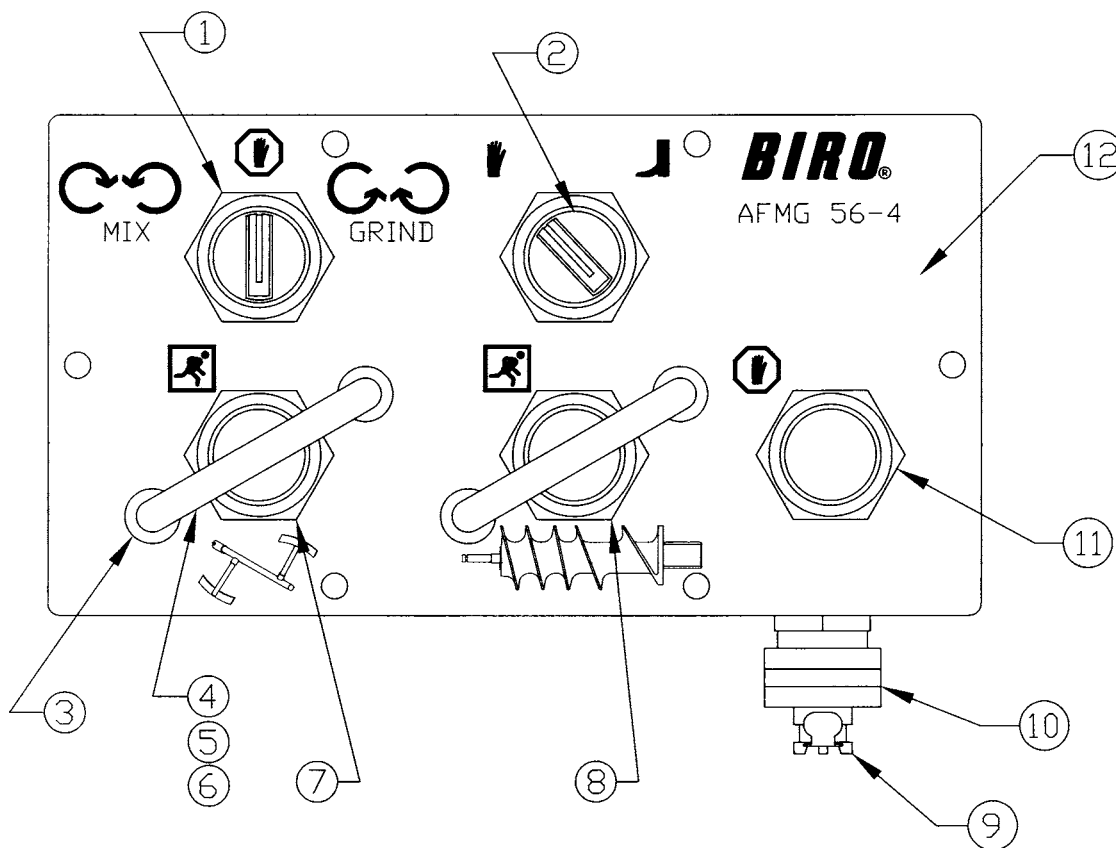

Fig.	Item No.	Description
1	EMG90676	Selector switch, 3 position paddle direction
2	EMG90668	Selector switch, 2 position hand/foot
3	H462-1	Trim ferrule (4 req'd.)
4	50655-1	Switch guard (2 req'd.)
5	LW15S	$\frac{5}{16}$ lock washer (4 req'd.)
6	HN20S	$\frac{5}{16}$ -18 hex nut (4 req'd.) (opposite side, not shown)
7	42MC-Y73	Start switch, mixer
8	42MC-Y73	Start switch, grinder
9	56300J-CPB	Coupling body, female
10	224-6	Cord grip connector, $\frac{1}{2}$ , .375-.500
11	42MC-Y74	Stop switch, all
12	40436	Front cover, pushbutton enclosure

# AFMG-56-4

## S/N 456101-456102, 456105-456110

### ELECTRICAL SUBPLATE COMPONENTS

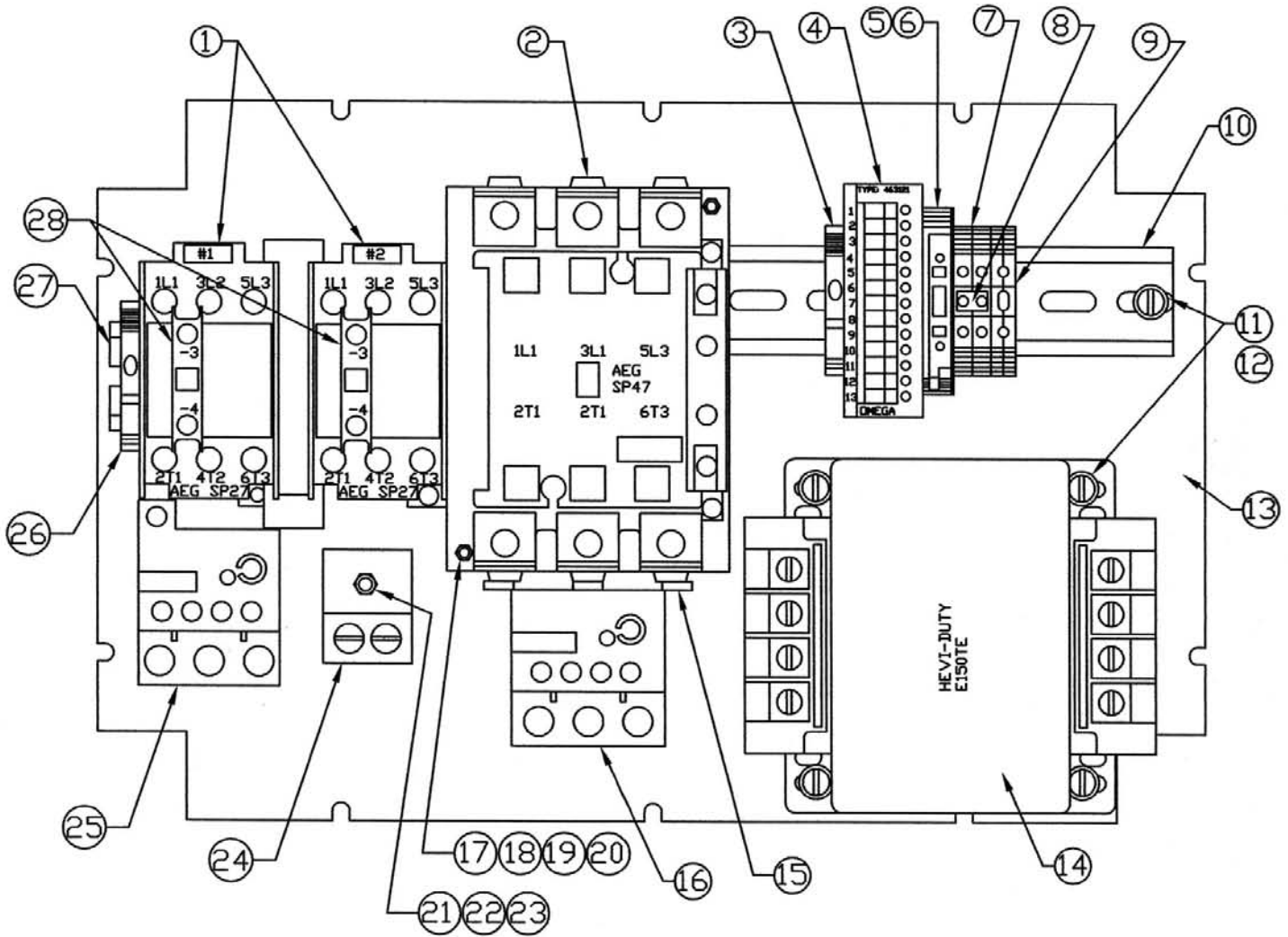

FIG.	ITEM NO.	DESCRIPTION	FIG.	ITEM NO.	DESCRIPTION
1	60069	REVERSING CONTACTOR	16	H281AE-32	OVERLOAD, 23AMP (440V)
2	60068	GRINDER CONTACTOR	16	H281AE-34	OVERLOAD, 50AMP (220V)
3	BLK323	END BARRIER	17	HHS018S	10-32 X 1-1/4
4	PC162	CENTRAL CONTROL UNIT	18	FW04S	HEX HEAD SCREW-2 REQ'D.
5	EMG92014	FUSE BLOCK	19	LW05S	#10 FLAT WASHER-2 REQ'D.
6	EMG90552	FUSE, 3 AMP. TIME DELAY	20	HN10S	#10 LOCK WASHER-2 REQ'D.
7	PC152	TERMINAL, -2 REQ'D.	21	HHS040S	10-32 HEX NUT-2 REQ'D.
8	PC257	INTERNAL JUMPER	21	HHS040S	1/4-20 X 3/4
9	BLK322	GROUND BLOCK	22	LW10S	HEX HEAD SCREW-1 REQ'D.
10	60053	DIN RAIL, 5-5/8"	23	HN10S	1/4 LOCKWASHER-1 REQ'D.
11	RHS09S	10-32 X 3/8 RND. HD. SCREW, -8 REQ'D.	24	60103	1/4-20 HEX NUT-1 REQ'D.
12	FW04S	#10 FLAT WASHER, -8 REQ'D.	25	226AE-DL08L	GROUNDING BLOCK
13	60051	SUBPLATE	25	226AE-DL17N	OVERLOAD, 8AMP (440V)
14	PC141-1	TRANSFORMER, E150TE	26	BLK323	OVERLOAD, 17AMP (220V)
15	60096	BUS LINK,	27	60052	END BARRIER
			28	PC146	DIN RAIL, 4-1/4"
					AUX. CONTACT, N.O. -2 REQ'D.

CAD NO. 56MG-5 SCALE: 1"=1"

AFMG-56-4  
 S/N 456103-456104  
 S/N 456111-DN  
 ELECTRICAL SUBPLATE COMPONENTS

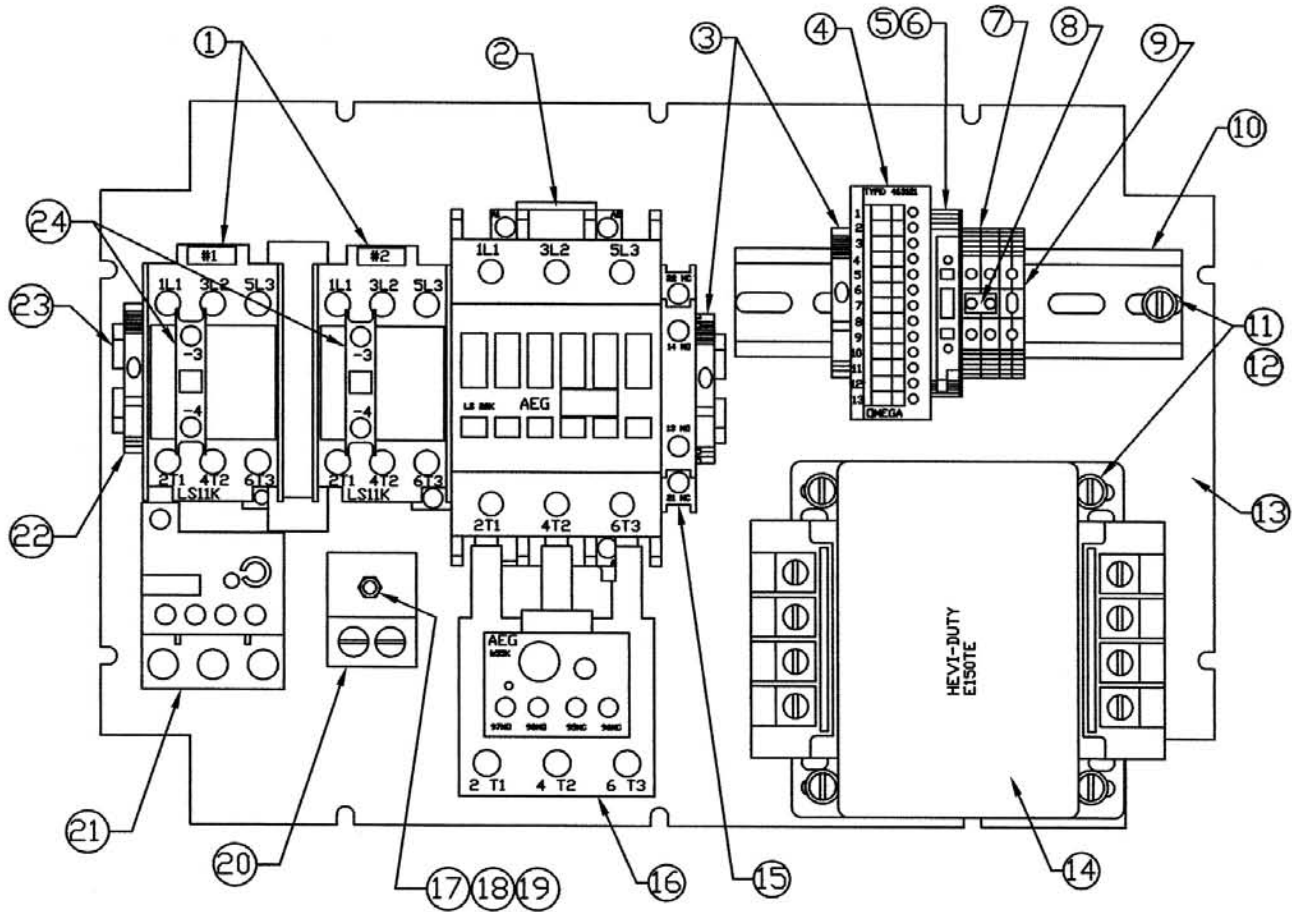
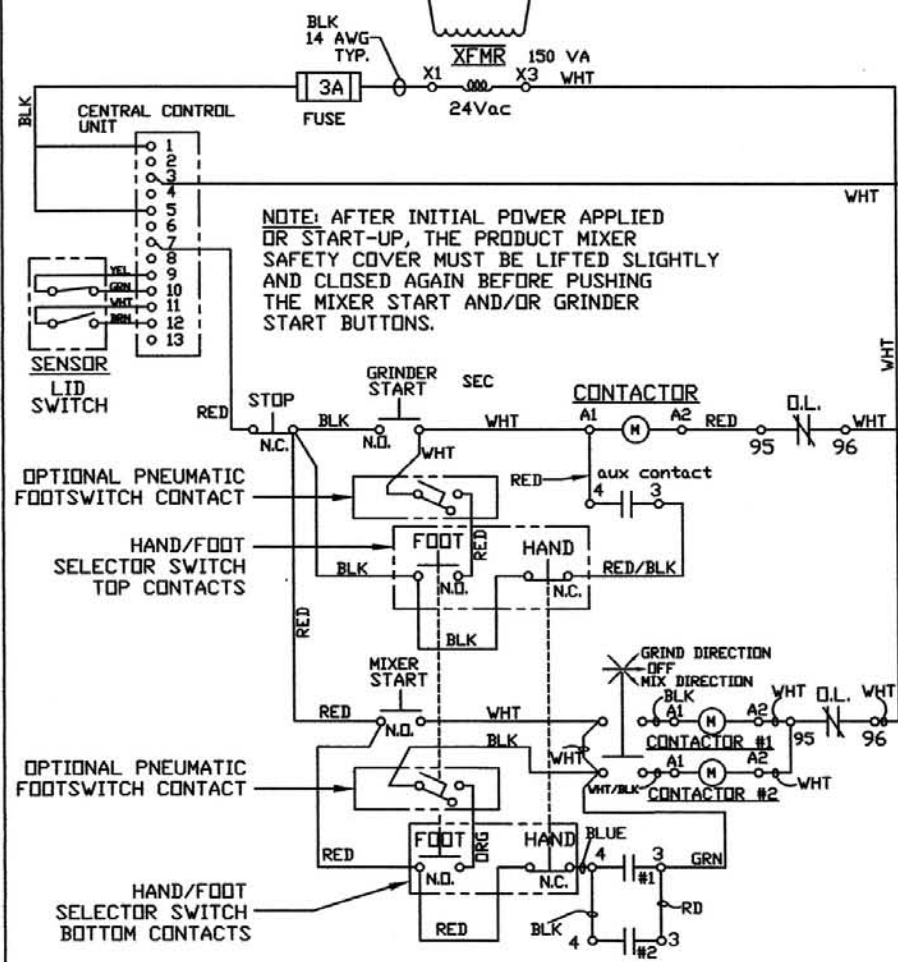
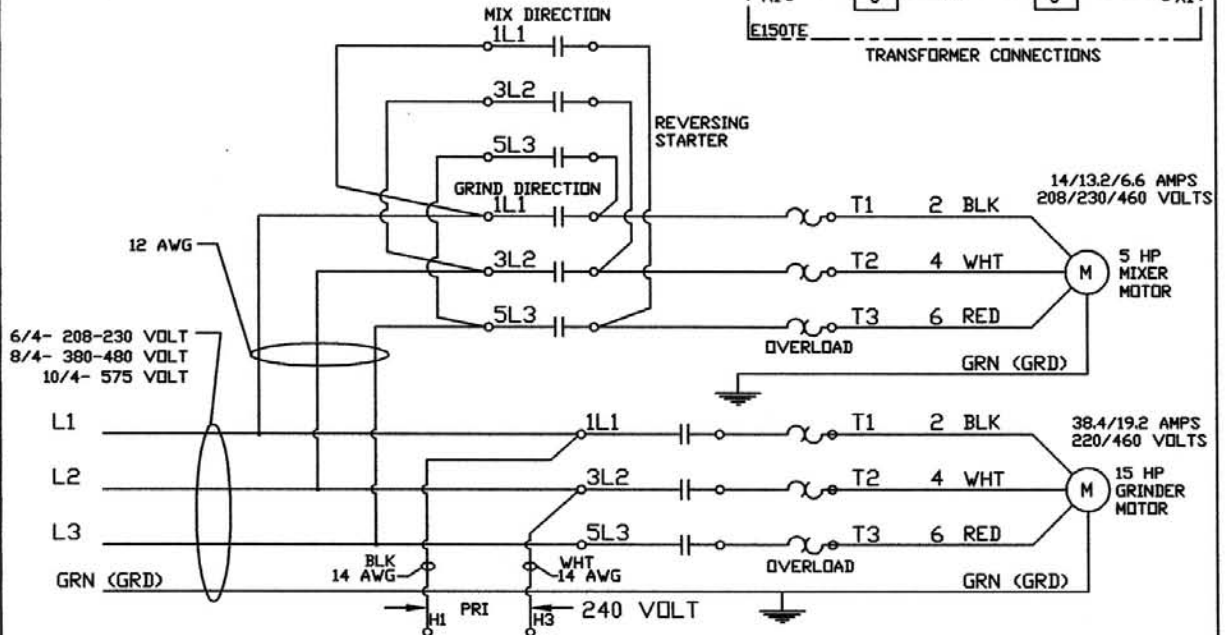
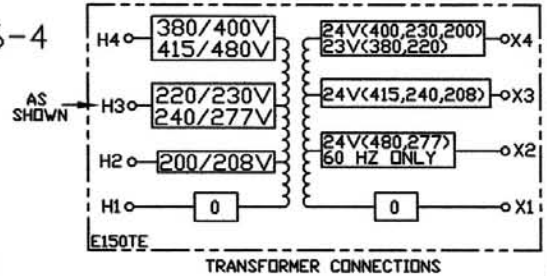

FIG.	ITEM NO.	DESCRIPTION	FIG.	ITEM NO.	DESCRIPTION
1	60069-1	REVERSING CONTACTOR	16	H281EE-43	OVERLOAD, 25AMP (440V)
2	57027-AE-CE	GRINDER CONTACTOR		H281EE-44	OVERLOAD, 43 AMP (220V)
3	BLK323	END BARRIER	17	HHS040S	1/4-20 X 3/4
4	PC162	CENTRAL CONTROL UNIT	18	LW10S	HEX HEAD SCREW-1 REQ'D.
5	EMG92014	FUSE BLOCK	19	HN10S	1/4 LOCKWASHER-1 REQ'D.
6	EMG90552	FUSE, 3 AMP. TIME DELAY	20	60103	1/4-20 HEX NUT-1 REQ'D.
7	PC152	TERMINAL,-2 REQ'D.	21	H281EE-52	GROUNDING BLOCK
8	PC257	INTERNAL JUMPER		H281EE-31	OVERLOAD,8.5AMP (440V)
9	BLK322	GROUND BLOCK	22	BLK323	OVERLOAD,16AMP (220V)
10	60053	DIN RAIL, 5-5/8"	23	60053-1	END BARRIER
11	RHS09S	10-32 X 3/8 RND. HD.	24	EMG90194	DIN RAIL, 8.00"
		SCREW, -8 REQ'D.			AUX. CONTACT, N.D. -2 REQ'D.
12	FW04S	#10 FLAT WASHER,-8 REQ'D.			
13	60051	SUBPLATE			
14	PC141-1	TRANSFORMER, E150TE			
15	226EE-HSK11	AUX. CONTACT, N.D.,-2 REQ'D.			

ELECTRICAL SCHEMATIC AFMG-56-4  
 SERIAL NO 456101-456102  
 SERIAL NO 456105-456110  
 WITH PNEUMATIC FOOT SWITCH  
 THREE PHASE



NOTE: AFTER INITIAL POWER APPLIED OR START-UP, THE PRODUCT MIXER SAFETY COVER MUST BE LIFTED SLIGHTLY AND CLOSED AGAIN BEFORE PUSHING THE MIXER START AND/OR GRINDER START BUTTONS.

- GRINDER MOTOR CONTACTOR W/OVERLOAD XSP47.11-GDW/INC,IND AUX.
- AUX CONTACT 3,4 N/O ATTACHED ON GRINDER MOTOR CONTACTOR
- FOOT/HAND SELECTOR SWITCH SHOWN IN THE HAND MODE
- MIXER MOTOR CONTACTORS W/OVERLOAD RSP27.10-GO
- MIXER PADDLES GRIND DIRECTION
- MIXER PADDLES MIX DIRECTION
- AUX CONTACTS 3,4 N/O ATTACHED ON MIXER MOTOR CONTACTORS, 1&2

# ELECTRICAL SCHEMATIC AFMG-56-4

S/N 456103-456104  
S/N 456111-0N  
WITH PNEUMATIC FOOT SWITCH  
THREE PHASE

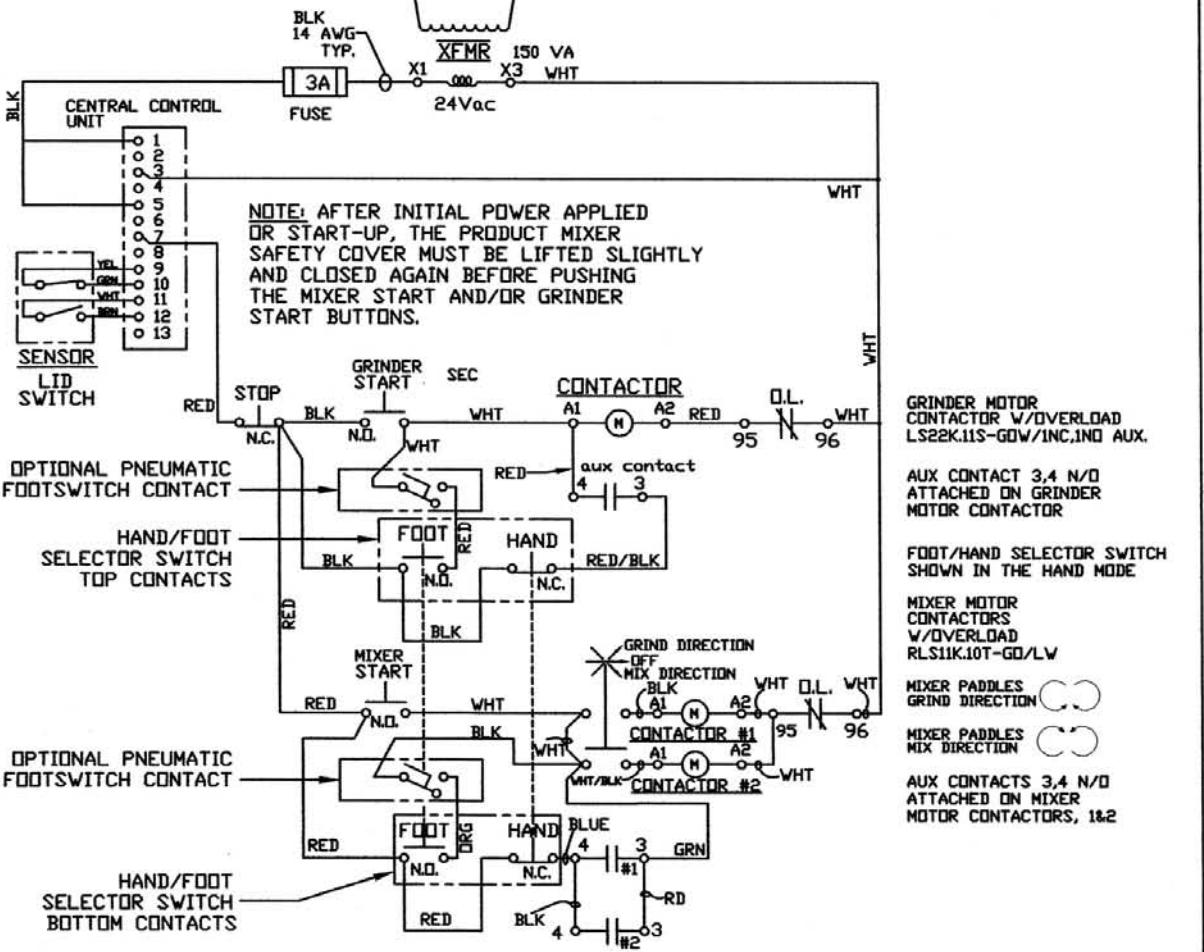
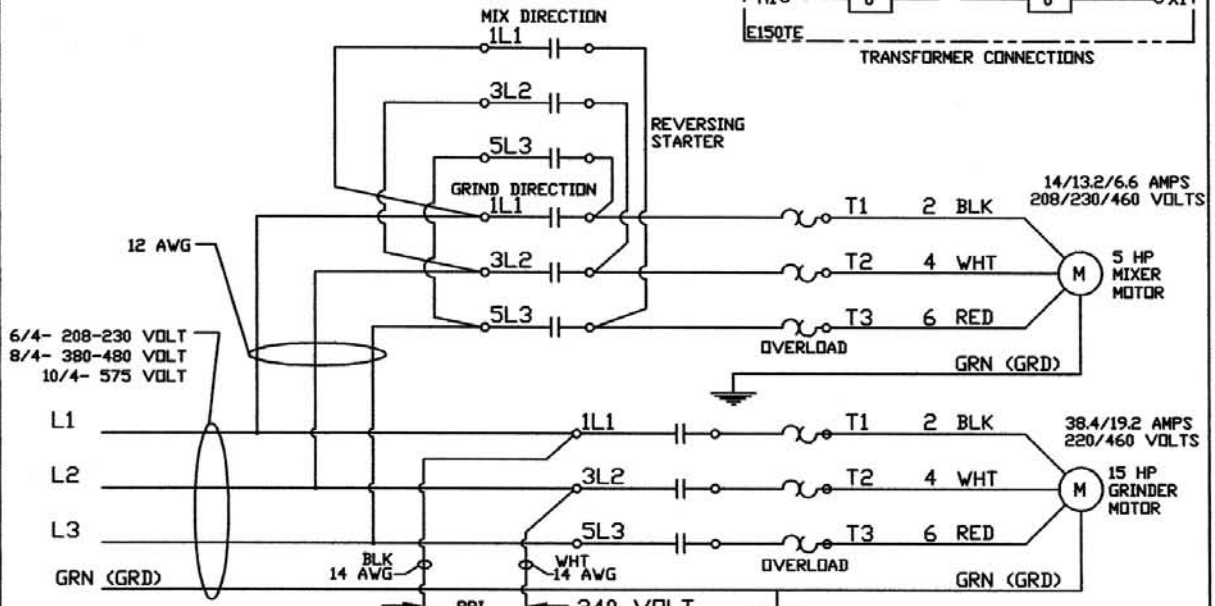
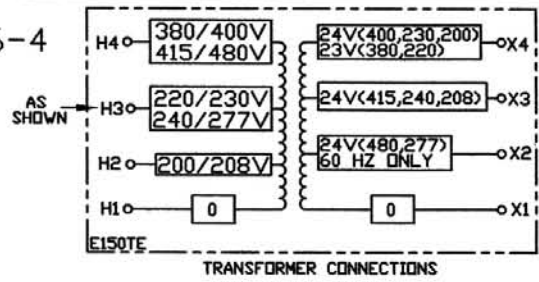

TANDEM OPERATION ILLUSTRATION  
FOR AFMG-56-4 INTO AFMG-56-4

— NOTE —  
60" DEEP  
OVERALL

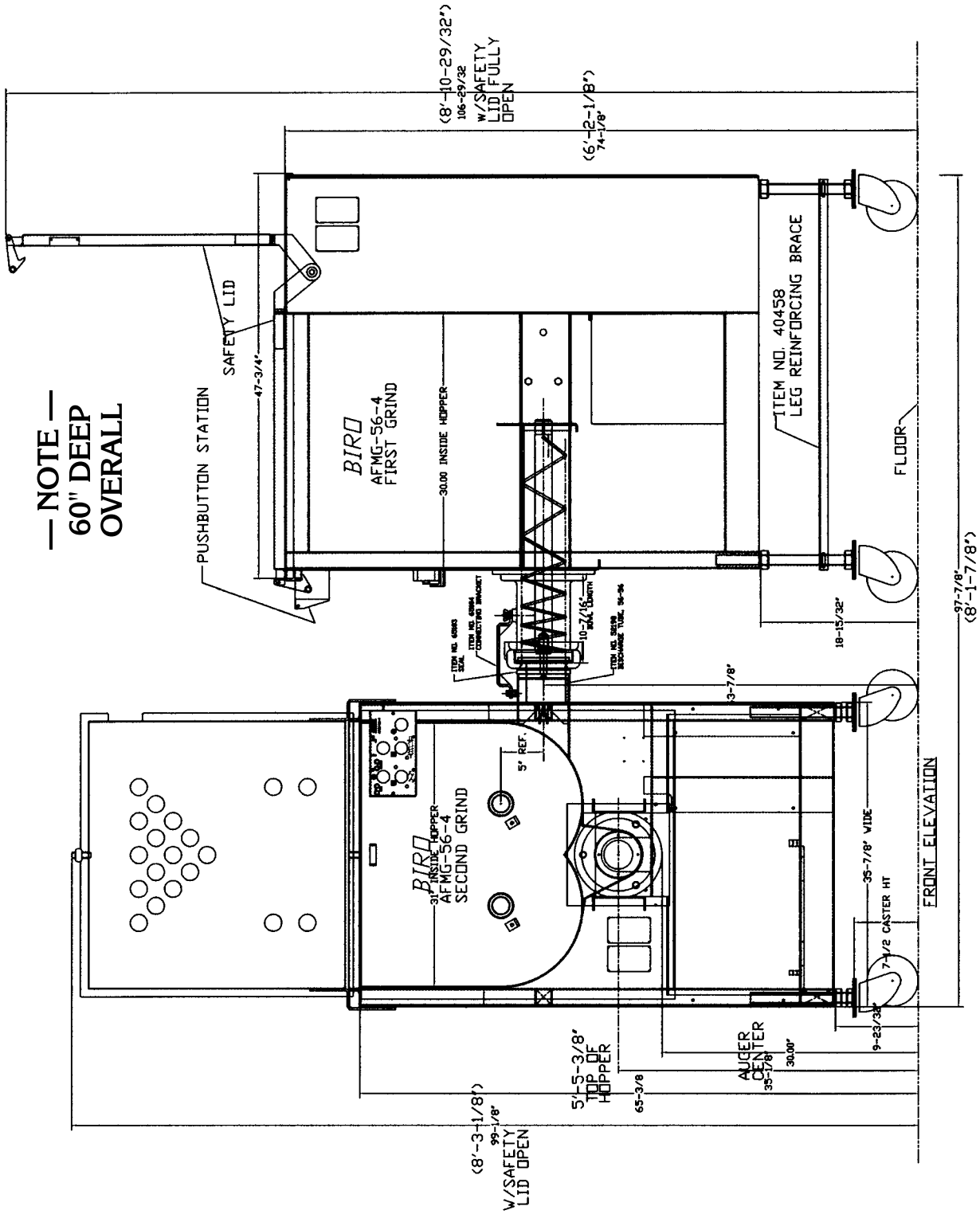

TANDEM OPERATION ILLUSTRATION  
FOR MANUAL FEED INTO AFMG-56-4

— NOTE —  
60" DEEP  
OVERALL

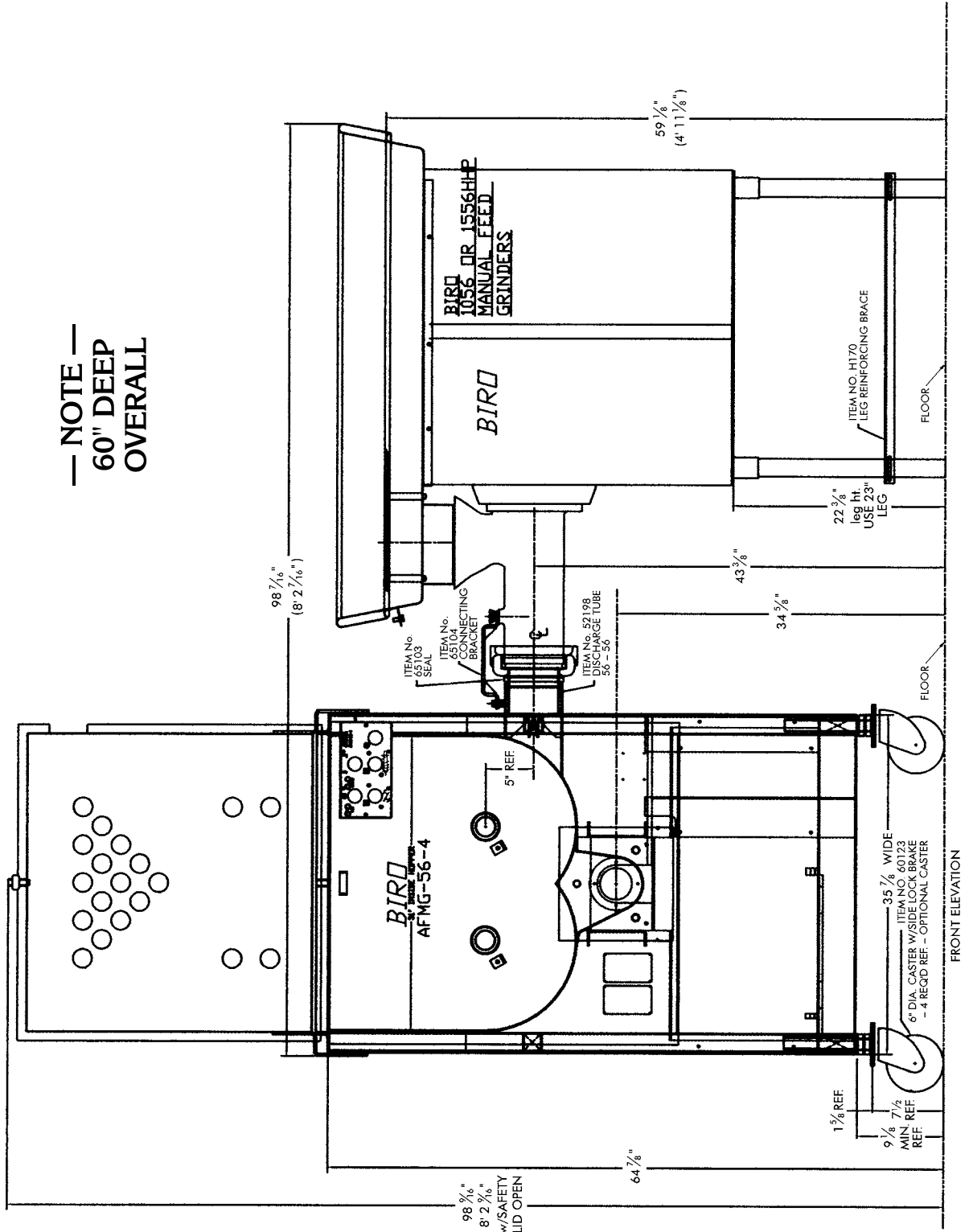

# SAFETY LABEL LOCATIONS

**CAUTION  
KEEP HANDS OUT OF HOPPER**

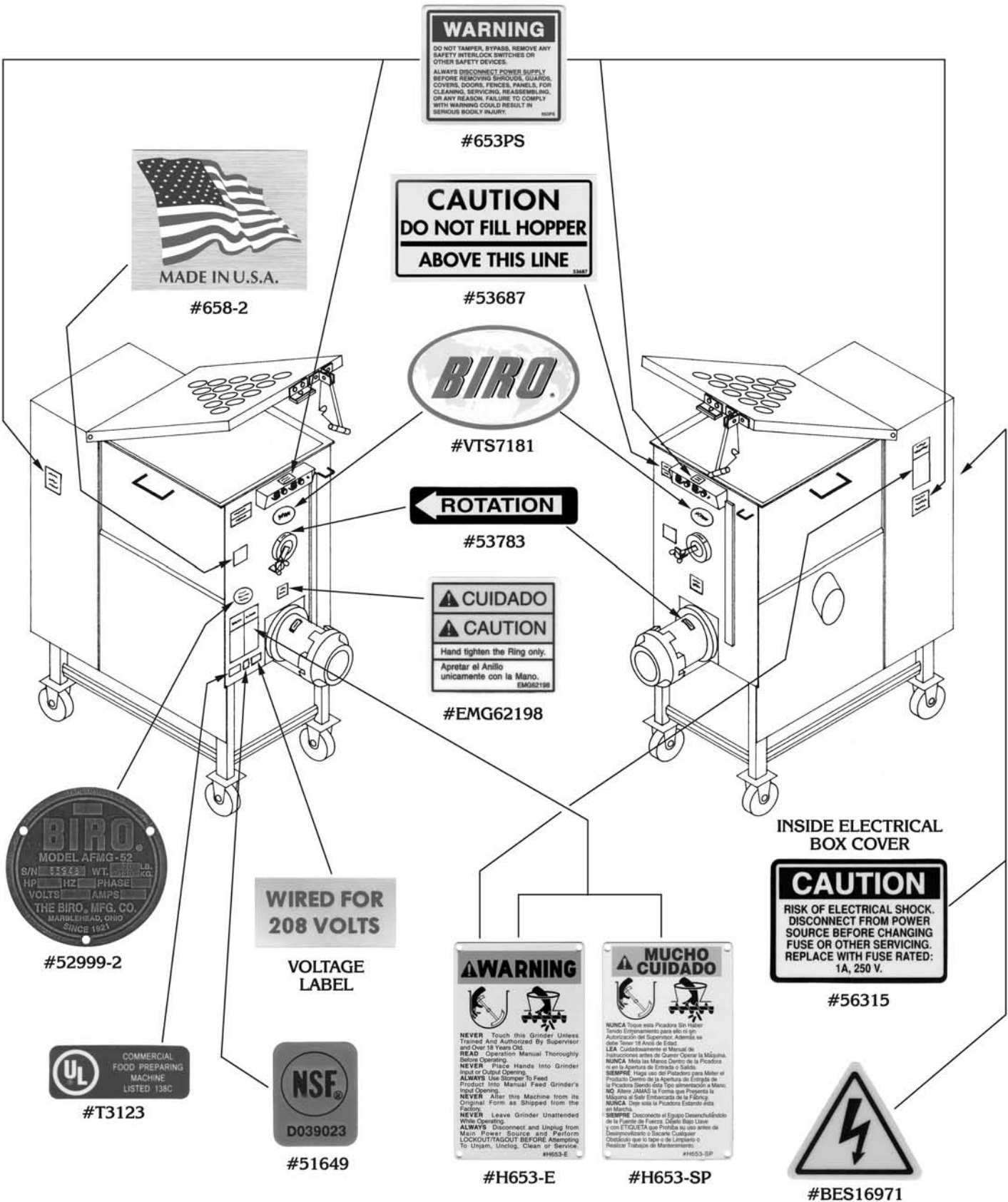



— NOTES —

— NOTES —



## LIMITED WARRANTY

**WARRANTY:** The Biro Manufacturing Company warrants that the BIRO AFMG-56-4 Mixer Grinder/Chopper will be free from defects in material and workmanship under normal use and with recommended service. BIRO will replace defective parts, which are covered by this limited warranty, provided that the defective parts are authorized for return, shipping charges prepaid, to a designated factory for inspection and/or testing.

**DURATION OF WARRANTY:** The warranty period for all parts covered by this limited warranty is one (1) year from date of inspection/demonstration as advised on the returned Warranty registration card, or eighteen (18) months from original factory shipping date, whichever date occurs first, except as noted below.

**PARTS NOT COVERED BY WARRANTY:** The following are **not** covered by this limited warranty: wearable parts in the grinding system such as bowl, ring, worm, drive shaft, and knife drive pin. This limited warranty does not apply to machines sold as used, rebuilt, modified, or altered from the original construction in which the machine was shipped from the factory. Water contaminated electrical systems are not covered under this limited warranty. BIRO is not responsible for electrical connection of equipment, adjustments to the switch controls or any other electrical requirements, which must be performed only by a certified electrician. BIRO is not responsible for service charges or labor required to replace any part covered by this limited warranty or for any damages resulting from misuse, abuse, lack of proper or recommended service.

**EXCLUSION OF WARRANTIES AND LIMITATION OF REMEDIES:** BIRO gives no warranties other than those expressly stated in this limited warranty. THE IMPLIED WARRANTY OF MERCHANTABILITY, THE IMPLIED WARRANTY OF FITNESS FOR PROCESSING OF FOOD PRODUCTS, AND ALL OTHER IMPLIED WARRANTIES ARE SPECIFICALLY EXCLUDED. BIRO IS NOT LIABLE FOR CONSEQUENTIAL OR INCIDENTAL DAMAGES, EXPENSES, OR LOSSES. THE REMEDIES PROVIDED IN THIS BIRO LIMITED WARRANTY ARE PURCHASER'S SOLE AND EXCLUSIVE REMEDIES AGAINST BIRO.

**REGISTRATION CARDS:** You must sign, date and complete warranty registration card supplied with each machine. The warranty card must be returned to The Biro Manufacturing Company for proper registration. If no warranty card is returned to BIRO, the warranty period will begin from the date the machine was originally shipped from the factory.

### HOW TO GET SERVICE:

1. Contact the entity from whom you purchased the machine; or
2. Consult the yellow pages of the phone directory for the nearest authorized dealer; or
3. Contact BIRO Mfg. Company for the authorized service entity (250 plus worldwide) in your area.

## THE BIRO MANUFACTURING COMPANY

1114 Main Street

Marblehead, Ohio

Ph. 419-798-4451

Fax 419-798-9106

E-mail: [service@birosaw.com](mailto:service@birosaw.com)

Web: <http://www.birosaw.com>