



MODEL AFMG-52 AUTOMATIC FEED MIXER GRINDER OPERATING AND SERVICE MANUAL

STARTING WITH SERIAL NO. 52001

STARTING WITH SERIAL NO. 52101
(SIDE OPENING LID)

STARTING WITH SERIAL NO. 52345
(35° INLET/TRI DIRECTIONAL LID)



IMPORTANT NOTICE



This Manual contains important safety instructions which must be strictly followed when using this equipment.

PTCT
AFMG-52
232-4-12-14

— NOTES —

TABLE OF CONTENTS

	Page
NOTICE TO OWNERS AND OPERATORS	1
SAFETY TIPS	2
INSTALLATION	3
UNCRATING AND SETUP	3
MOTOR WIRING AND ELECTRICAL REQUIREMENTS	4
MOTOR SPECIFICATIONS	4
OPERATION	6
TO PROCESS PRODUCT	6
CLEANING	7
MAINTENANCE	8
GRINDING BOWL INSTALLATION	8
MIXING PADDLE INSTALLATION	8
LUBRICATION	8, 9, 10
NORD TRANSMISSION	9, 10
DORRIS TRANSMISSION	11
MIXER DRIVE BELT TENSION	11
MAIN DRIVE CHAIN AND SPROCKET LUBRICATION	11
MAIN DRIVE CHAIN TENSION	12
CHAIN REPLACEMENT	12
WIRING DIAGRAMS	13
OPERATOR'S NOTES	14
PARTS DIAGRAMS	15, 16, 17
STANDARD AND OPTIONAL STAINLESS STEEL BOWLS, AUGERS & END RINGS (130mm UNGER & ENTERPRISE)	18
PRODUCT MIXER SAFTY COVERS & LID LOCKS	19
JOURNAL BOX	20
ELECTRIC FOOTSWITCH	20
ITEMS REQUIRED FOR TANDEM OPERATION TO S/N 52344	21, 22
ITEMS REQUIRED FOR TANDEM OPERATION AFTER S/N 52345	23
CONNECTION INSTRUCTIONS FOR TANDEM OPERATION	24, 25
SAFETY LABEL LOCATIONS	26
OPERATOR'S SIGNATURE PAGE	27
OPERATOR'S NOTES	28
LIMITED WARRANTY	29

NOTICE TO OWNERS AND OPERATORS

BIRO's products are designed to process food products safely and efficiently. Unless the operator is properly trained and supervised, however, there is the possibility of a serious injury. It is the responsibility of the owner to assure that this machine is used properly and safely, strictly following the instructions contained in this Manual and any requirements of local law.

No one should use or service this machine without proper training and supervision. All operators should be thoroughly familiar with the procedures contained in this Manual. Even so, BIRO cannot anticipate every circumstance or environment in which its products will be used. You, the owner and operator, must remain alert to the hazards posed by the function of this equipment — particularly the ROTATING GRINDING AUGER and the ROTATING MIXING PADDLE, which can severely injure an inattentive operator amputating fingers and limbs. No one under eighteen (18) years of age should operate this equipment. If you are uncertain about a particular task, ask your supervisor.

This Manual contains a number of safe practices in the SAFETY TIPS section. Additional warnings are placed throughout the Manual. Warnings related to your personal safety are indicated by:



OR



Warnings related to possible damage to the equipment are indicated by:



BIRO also has provided warning labels on the equipment. If any warning label or Manual becomes misplaced, damaged, or illegible, please contact your nearest Distributor or BIRO directly for a replacement.

Remember, however, this Manual or the warning labels do not replace the need to be alert and to use your common sense when using this equipment.

This Manual applies to machines with serial number 52001 and higher, to machines with tri-directional product mixer safety cover and 35 degree inlet, serial number 52345 and higher.

- NOTE -

A copy of this manual is included with each AFMG-52 MIXER GRINDER.

The descriptions and illustrations contained in this manual are not binding. The manufacturer reserves the right to introduce any modification without updating the manual.

SAFETY TIPS

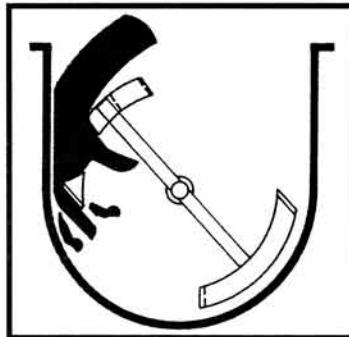

ROTATING GRINDING AUGER & ROTATING MIXING PADDLE TO AVOID SERIOUS PERSONAL INJURY

- **NEVER** Touch This Machine without Training and Authorization by Your Supervisor.
- **NEVER** Place Hands into Machine Input or Output Openings.
- **NEVER** Open Machine During Operation.
- **ONLY** Use a Qualified Electrician to Install According to Local Building Codes: Machine **MUST** Be Properly Grounded.
- **ALWAYS** Connect to **Proper** Voltage & Phase.
- **ONLY** Install on Level, Non-Skid Surface in a Clean, Well-Lighted Work Area Away from Children and Visitors.
- **ALWAYS** Lock Machine Castors After Moving This Machine.
- **NEVER** Use This Machine For Non-Food Products.
- **NEVER** Operate Machine With Product Mixer Safety Cover Open or Removed or Magnetic Interlock Switch By-Passed.
- **ALWAYS** Turn Off, Unplug Machine From Power Source and Perform Lockout/Tagout Procedure to this Machine **BEFORE** Attempting to Unjam or Unclog, Cleaning or Servicing
- **NEVER** Leave Machine Unattended While Operating.
- **NEVER** Alter This Machine From its Original Form as Shipped From Factory. **DO NOT** Operate Machine With Missing Parts.
- **PROMPTLY REPLACE** Any Worn or Illegible Warning Labels.
- **ALWAYS** Read Operation and Service Manual **BEFORE** Operating, Cleaning, or Servicing.
- **USE ONLY BIRO** Parts and Accessories Properly Installed.

INSTALLATION



TO AVOID SERIOUS PERSONAL INJURY, PROPERLY INSTALL EQUIPMENT IN ADEQUATE WORK AREA

- **ALWAYS** Use Qualified Technician and Electrician for Installation.
- **ALWAYS** Connect to **Proper** Voltage & Phase.
- **ALWAYS** Install Equipment in Work Area with Adequate Light and Space Away From Children and Visitors.
- **ONLY** Operate on a Solid, Level, Non-Skid Surface.
- **ALWAYS** Lock Machine Castors After Moving Machine to Operating Location.
- **NEVER** Bypass, Alter, or Modify This Equipment in Any Way From Its Original Condition.
- **NEVER** Operate With Product Mixer Safety Cover Opened or Removed or Magnetic Interlock Switch by-Passed.
- **NEVER** Operate Without all Warning Labels Attached and Owner/Operator Manual Available to the Operator.

UNCRATING AND SET UP

1. Read this Manual thoroughly before installation and operation. **Do not** proceed with installation and operation if you have any questions or do not understand anything in this Manual. Contact your local Distributor, or BIRO **first**.
2. Remove all banding, shipping carton, and all equipment from inside the tub. Then take machine off shipping pallet.
3. This machine is shipped with the adjustable legs fully retracted. The legs allow for a height adjustment from the floor to centerline of bowl $23\frac{9}{16}$ " minimum to $33\frac{1}{16}$ " maximum..
4. This machine weighs approximately 750 pounds. To avoid accidents block up machine after raising to desired operating height.
5. The adjustable legs can now be unbolted and lowered to the floor using the following steps.
 - a. Unbolt leg and while holding leg turn leg adjusting stud (Item No. 53985) clockwise until castor rests on floor.
 - b. Be sure bolt holes line up. Replace bolts and tighten securely.
6. Install machine on a level, non-skid surface in a well-lighted work area away from children and visitors.
7. This machine is complete except for knife and plate. There is a bowl shipping plug (stamped steel) placed in the output end of the grinding bowl to retain the grinding auger during shipment. **REMOVE THE BOWL SHIPPING PLUG AND THE GRINDING AUGER.**



8. After checking and making sure the power supply is correct, plug in your machine. **NEVER OPERATE THIS MACHINE WITH PRODUCT MIXER SAFETY COVER OPEN.** (Machine will not run with cover open.)
9. Machine must be properly grounded. Use qualified electrician to install according to local building codes.

MOTOR WIRING AND ELECTRICAL REQUIREMENTS

1. Interchange of current is made in motor outlet box. Leads are properly marked. Changing instructions are on the motor plate or motor outlet box.
2. All grinders are wired 220 volts unless otherwise specified. Be sure motor specifications (voltage, cycle, phase) match power supply line. Be sure line voltage is up to specification.
3. Electrical connections to be in accordance with safety codes and National Electrical Code.
4. Rated voltage of the unit shall be identical with full supply voltage.
5. Voltage drop on the supply line shall not exceed 10% of full supply voltage.
6. The feederline conductor size in the raceway from the branch circuit to the unit must be correct to assure adequate voltage under heavy starting and short overload conditions.
7. The feederline conductor shall only be used for the supply of one unit of the relevant horsepower. For connections of more than one unit on the same feederline, a local electrician will have to be consulted to determine the proper conductor size.
8. The size of the electrical wiring required from the power source to the mixer grinder with 7½HP grind motor is a **MINIMUM OF No. 10 WIRE**. With 10HP grind motor **MINIMUM OF No. 8 WIRE** to be used.
9. The BIRO Manufacturing Company is not responsible for permanent wiring, connection or installation



NOTE TO OWNER AND ELECTRICIAN: IF THIS MACHINE IS NOT CORD AND PLUG CONNECTED TO THE ELECTRICAL SUPPLY SOURCE, THEN IT SHOULD BE EQUIPPED WITH, OR CONNECTED TO, A LOCKABLE, MANUALLY-OPERATED DISCONNECT SWITCH (OSHA 1010.147).

3-PHASE MOTOR SPECIFICATIONS AND OVERLOADS

MIXER MOTORS

BALDOR/DORRIS MOTOR	Voltage	Cycles	Overload	Amps	Item No.
1HP/.75kw	200	60	E-41	3.7	53900
"	208	60	E-41	3.6	53900
"	220	60	E-41	3.5	53900
"	230	60	E-41	3.4	53900
"	440	60	E-29	1.8	53922
"	460	60	E-29	1.7	53922
"	575	60	E-27	1.3	53997
"	220	50	E-44	4.2	53924
"	380	50	E-34	2.1	53926
"	415	50	E-34	2.0	53926
BALDOR/DORRIS MOTOR	Voltage	Cycles	Overload	Amps	Item No.
1.5HP/1.1kw	200	60	E-48	5.5	50669
"	220	60	E-48	5.0	50669
"	440	60	E-38	2.5	52740
"	460	60	E-36	2.4	52739
"	575	60	E-33	1.9	52729
"	220	50	E-48	6.0	50669
"	380	50	E-39	3.5	52732
"	415	50	E-39	3.2	52732

NORD HIGH EFF. MOTOR	Voltage	Cycles	Overload	Amps	Item No.
1¾HP/1.3kw	200	60	E-50	5.9	50668
"	208	60	E-50	5.7	50668
"	220	60	E-50	5.4	50668
"	230	60	E-50	5.2	50668
"	440	60	E-36	2.7	52739
"	460	60	E-36	2.6	52739
"	550	60	E-34	2.2	53926
"	575	60	E-34	2.1	53926
"	200	50	E-48	7.1	50669
"	380	50	E-39	3.7	52732
"	415	50	E-41	3.4	53900

GRINDER MOTORS

BALDOR MOTOR	Voltage	Cycles	Overload	Amps	Item No.
7.5HP/5.6kw	200	60	E-70	25	53925
"	208	60	E-69	24	54219
"	220	60	E-67	23	52609
"	230	60	E-67	22	52609
"	440	60	E-56	11.5	52743
"	460	60	E-56	11	52743
"	575	60	E-54	8.8	50705
"	220	50	E-70	27.6	53925
"	380	50	E-61	16	52744
"	415	50	E-60	14.6	50667

10HP/7.5kw	Voltage	Cycles	Overload	Amps	Item No.
"	200	60	E-72	30	57028
"	208	60	E-72	28.8	57028
"	220	60	E-70	27.2	53925
"	230	60	E-70	26	53925
"	440	60	E-60	13.6	50667
"	460	60	E-60	13	50667
"	575	60	E-56	10.4	52743
"	220	50	E-72	32.6	57028
"	380	50	E-62	18.8	50704
"	415	50	E-62	17.3	50704

10. Two sets of green and red pushbuttons are located on the front of the machine that activate the magnetic contactors that control the mix and grind motors. The magnetic interlock switch is mounted in the pushbutton box. It lines up with the magnet attached to the product mixer safety cover. When the safety cover is raised the machine will stop operation.
11. Push the green start button for grind. **CHECK THE ROTATION OF THE AUGER DRIVE SHAFT; ROTATION MUST BE COUNTER-CLOCKWISE** as indicated by the rotation decal affixed to the grinding bowl. **ROTATION MUST ONLY BE CHECKED WITH THE GRINDING AUGER REMOVED**, otherwise serious irreparable damage may occur to grinding components.
12. Push the green start button for mix. **CHECK ROTATION OF THE MIXING PADDLE; ROTATION MUST BE COUNTER-CLOCKWISE** as indicated by the rotation decal located on the paddle front mounting hub. Backwards operation will not allow mixing paddle to feed product to the grinding auger.



13. If machine runs clockwise (backwards), it must be rewired to correct rotation, otherwise serious irreparable damage may occur to grinding components. Both the auger and the mixing paddle must operate in the same direction.
14. Check operation of optional footswitch if equipped. Plug footswitch cord into fitting at the bottom of the pushbutton control box. Move toggle selector to foot. The machine will operate with pressure on the footswitch treadle. Releasing the treadle stops the machine. The footswitch operates the mix and grind together.
15. Insert auger assembly into grinding bowl, place knife (sharp edges out) onto the square end of the auger assembly. The breaker plate slides over the worm knife drive pin, and is held from rotating by pins in the grinding bowl. Install the retaining ring.



ONLY HAND TIGHTEN RETAINING RING

For best results, use knife and plate as a set. **Do not operate machine for any period of time without product in the grinding bowl.** This will cause heating and dulling of the knife and plate.

16. Check placement of all warning labels and Manual. Machine is now ready for trained operators to process product.
17. Use meat deflector attached to grinding bowl to eliminate meat splatter.
18. Contact your local Distributor or BIRO directly if you have any questions or problems with the installation or operation of this machine.

OPERATION



ROTATING GRINDING AUGER & ROTATING MIXING PADDLE TO AVOID SERIOUS PERSONAL INJURY

- **ONLY** Properly Trained Personnel Should Use This Equipment.
- **NEVER** Place Hands Into Machine Input or Output Openings.
- **NEVER** Open Machine During Operation.
- **DO NOT** Wear Gloves While Operating.
- **DO NOT** Tamper With, Bypass, Alter, or Modify This Equipment in Any Way From Its Original Condition.
- **NEVER** Operate Machine With Product Mixer Safety Cover Opened or Removed or Magnetic Interlock Switch By-Passed.
- **ALWAYS** Turn Off and Unplug Machine from Power Source and Perform Lockout/Tagout Procedure to This Machine Before Unjamming, Unclogging, Cleaning or Servicing.
- **NEVER** Leave Unattended While Operating.
- **NEVER** Operate Without All Warning Labels Attached and Owner/Operator Manual Available to the Operator.

A. TO PROCESS PRODUCT

1. Before starting mixer grinder, have a container for receiving ground product at the output end of the grinding bowl.
2. **FIRST GRIND**
 - a. Fill Product Hopper (Maximum 200 Pounds), close Product Mixer Safety Cover.
 - b. Push both grind and mix green start buttons to feed first grind. It is recommended to use a breaker plate with $\frac{3}{8}$ " diameter or larger holes.
 - c. Push both grind and mix red stop buttons when all product has been ground out.
3. **SECOND GRIND**
 - a. Fill Product Hopper (Maximum 200 Pounds), close Product Mixer Safety Cover.
 - b. Push the mix green start button only. During this mix operation seasonings may be added through the sight holes in the Product Mixer Safety Cover.
 - c. After the desired mix, push the green grind start button to operate grinding auger and grind out product.
 - d. Push both grind and mix red stop buttons when all product has been ground out.
4. Unplug from power source and perform lockout/tagout procedures.

CLEANING



ROTATING GRINDING AUGER & ROTATING MIXING PADDLE TO AVOID SERIOUS PERSONAL INJURY

- **ALWAYS** Turn Off, Unplug From Power Source and Perform Lockout/Tagout Procedures to This Machine **Before** Cleaning or Servicing.
- **ONLY** Use Recommended Cleaning Equipment, Materials, and Procedures.
- **NEVER** Spray Water or Other Liquid Substances Directly at Motor, Power Switch or any Other Electrical Components.
- **ALWAYS** Thoroughly Clean Equipment at Least Daily.

CLEANING THE BIRO MIXER GRINDER

1. Disconnect mixer grinder from power source and perform lockout/tagout procedures.
2. Remove grinding bowl end ring, breaker plate, knife and grinding auger.
3. Remove mixing paddle. Be sure front most paddle arm is pointing up. Loosen the thumb screw on the mixer paddle lock arm (Item No. 53852). While supporting the mixing paddle, remove the lock arm. Turn the mixing paddle counterclockwise, slide forward to disengage from drive shaft and lift from product hopper.



DO NOT POWER SPRAY DIRECTLY AT ELECTRICAL COMPONENTS

4. Machine is now ready to be cleaned using warm soapy water and rinsed with clean water. Machine may be cleaned by power spray washing, taking care to not spray directly at any electrical controls.
5. The grinding head can be removed for cleaning if desired. This is accomplished by removing the three nuts on the back flange of the grinding head.
6. After machine has been cleaned and allowed to dry, all exposed metal surfaces should be coated with a good food grade light oil or grease.

CLEANING THE BOWL - RING AND WORM CARE OF TIN COATED PRODUCTS (DO'S AND DON'TS)

1. Do not use abrasive cleaning materials, such as Brillo pads or metal scrapers. Tin is a soft metal and should be cleaned with a soft cloth and dried.
2. Do not use a cleaning agent containing a high percentage of free alkali or acid.
3. Do not use detergent containing a high percentage of tri-sodium phosphate or meta-silicate. Tin is reactive to both.
4. Rinse well and dry thoroughly after washing to remove agents that may be reactive to tin.
5. If sterilizing agent containing chlorine is used, the tinned surface must be thoroughly rinsed. Chlorine is corrosive to tin.
6. Dry thoroughly after rinsing and store in a dry environment.
7. If water is exceptionally hard, drying will be necessary to prevent spotting.

MAINTENANCE



ROTATING GRINDING AUGER & ROTATING MIXING PADDLE TO AVOID SERIOUS PERSONAL INJURY

- **ALWAYS** Turn Off, Unplug from Power Source and Perform Lockout/Tagout Procedures to This Machine **BEFORE** Servicing.
- **NEVER** Touch This Machine Without Training and Authorization By Your Supervisor
- **NEVER** Place Hands Into Machine Input or Output Openings.
- **NEVER** Bypass, Alter or Modify This Equipment in Any Way From Its Original Condition.
- **PROMPTLY REPLACE** Any Worn or Illegible Warning Labels.
- **USE ONLY GENUINE BIRO** Parts and Accessories Properly Installed.

A. GRINDING BOWL INSTALLATION

1. Mount the grinding bowl on the three threaded studs on the front of the machine. Tighten in position with provided nuts.
2. Place the grinding auger in the grinding bowl and fully seat rear drive tang into auger drive shaft.
3. Install knife, breaker plate and end retaining ring.



ONLY HAND TIGHTEN RETAINING RING

4. When the bowl assembly is mounted and tight, there should be approximately $\frac{1}{8}$ " gap between the back inside wall of the grinding trough and the back of the auger. The bowl ring wrench which is provided with each mixer grinder is used only for **REMOVAL** of the end retaining ring for cleaning purposes or for changing knife and breaker plate.

B. MIXING PADDLE INSTALLATION

1. Check that mixer paddle drive pin (Item No. 53516) in the mixer paddle drive shaft (Item No. 53955-N) is positioned vertically.
2. Holding the mixing paddle by the center shaft and with the front blade up carefully fit drive receiving collar onto the end of the drive shaft. Insert paddle lock arm assembly (Item No. 53852) into the front of the mixing tub and onto the front of the mixing paddle.
3. When fully seated, turn the lock arm counterclockwise so the protruding arm is behind the lock set screw bracket. Tighten the mixer paddle lock set screw (Item No. 53568).

C. LUBRICATION

1. **MOTORS:** The mix and grind motors have pre-lubricated bearings. These bearings should be re-lubricated annually with a good grade of bearing grease. Do not over-grease.
2. **BEARING HOUSING:** The main bearings are housed in an enclosed and sealed journal box. Re-lubricate semi-annually with a good grade of bearing grease. Do not over-grease.

OPERATING AND MAINTENANCE INSTRUCTIONS STARTING WITH SERIAL No. 55665

3. FOR NORD HELICAL – WORM GEAR AND MOTOR REDUCER

ELECTRICAL CONNECTIONS

Check the motor nameplate to verify the phase, hertz and voltage agrees with the available power supply. Connection should conform to local codes. A connection diagram for the motor is located inside the conduit box and on the motor nameplate. The motor starter has overload protector.



NORD GEAR CORP.

800 Nord Drive
P.O. Box 376
Waunakee, WI 53597-0367

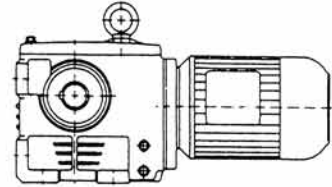

START-UP

All units are lubricated before shipment. The lubricant level should be checked with the unit mounted in its correct operating position. Lubricant should be added or removed to bring it to the correct level.

MAINTENANCE

A. MOTOR

During maintenance, inspect the fan guard and remove any accumulated debris from under or around the gear reducer. Motor bearings are greased and sealed for life. Motor requires no periodic maintenance.

B. GEAR REDUCER

All units are filled from factory with ISO VG680as. This is a Polyglycol (PG) type synthetic lubricant. Units should be checked periodically for increase noise, surface temperature, vibration, shaft movement, and amperage draw. Gear reducer should have the lubricant changed every 20,000 hours or four years, whichever occurs first. For adverse operating conditions the interval should be shorter. **DO NOT MIX SYNTHETIC & MINERAL BASE OILS.** After the unit is drained of the used lubricant, it should be filled with approximately 1.48 Qts. of a compatible lubricant to the above specification. Once the unit is filled, the lubricant level should be verified at the Oil Level Plug.

Please note the chart below for oil compatibility:

Oil Compatibility		
Polyglycol	Mineral	No
Polyalphaolefin	Polyglycol	No
Polyalphaolefin	Mineral	Yes

The listing below offers suggestions on the manufacturers of recommended lubricants. Use synthetic oil (Polyglycol-Base) between 14 – 175° with an ISO Viscosity Class of ISO VG 680.

Aral Degol GS 680	Klober Klubersynth GH 6-680
BP Enersyn SG-XP 680	Mobile Glycgoyle HE 680
Texaco Pinnacle 680	Tribol 800/680
	Shell Omala HD 680

Starting with Serial No. 55665

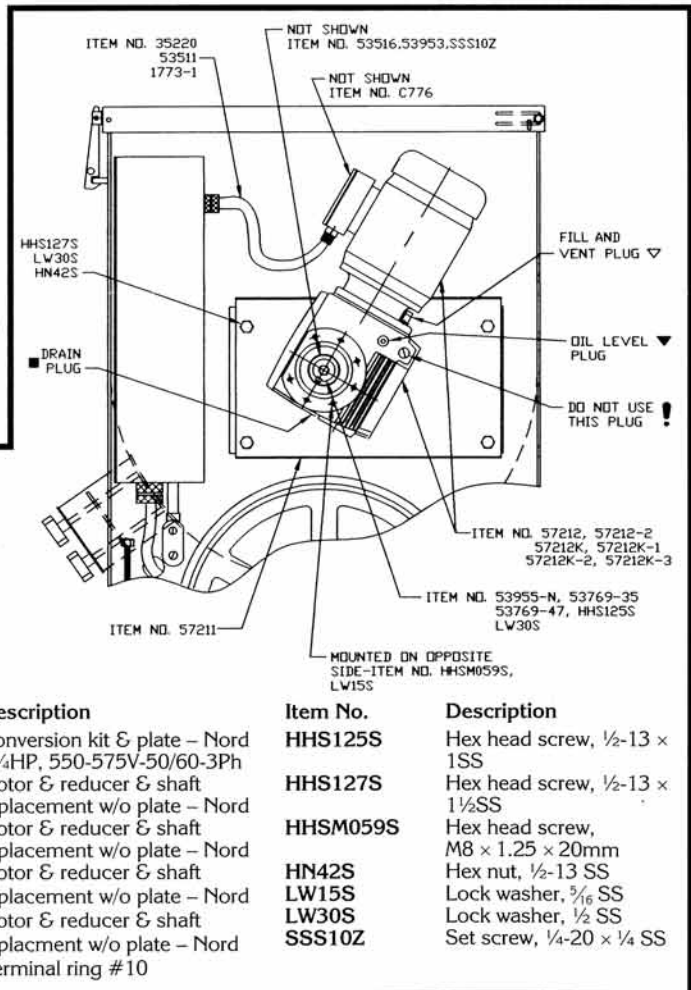

Item No.	Description
1773-1	Lock Ring ½"
35220	Motor cord SO 14/4 x 41"
53511	Cord connector 14/4 AL.
53516	Mixer paddle drive pin
53769-35	Mixer drive shaft key
53769-47	Mixer shaft washer retainer
53953	Mixer drive shaft seal
53955-N	Mixer drive shaft
57211	Mounting plate
57212	Motor & reducer only – Nord 1¼HP, 208/460V-50/60-3Ph.
57212-1	Motor reducer only – Nord 1¼HP, 200/60-3Ph
57212-2	Motor & reducer only – Nord 1¼HP, 550-575V-50/60-3Ph
57212K	Conversion kit & plate – Nord 1¼HP, 200-230V-50/60-3Ph
57212K-1	Conversion kit & plate – Nord 1¼HP, 380-415V-50/60-3Ph
57212K-2	Conversion kit & plate – Nord 1¼HP, 440-460V-50/60-3Ph

Item No.	Description
57212K-3	Conversion kit & plate – Nord 1¼HP, 550-575V-50/60-3Ph
57212K-208	Motor & reducer & shaft replacement w/o plate – Nord
57212K-380	Motor & reducer & shaft replacement w/o plate – Nord
57212K-440	Motor & reducer & shaft replacement w/o plate – Nord
57212K-575	Motor & reducer & shaft replacement w/o plate – Nord
C776	Terminal ring #10

Item No.	Description
HHS125S	Hex head screw, ½-13 x 1SS
HHS127S	Hex head screw, ½-13 x 1½SS
HISM059S	Hex head screw, M8 x 1.25 x 20mm
HN42S	Hex nut, ½-13 SS
LW15S	Lock washer, ⅜ SS
LW30S	Lock washer, ½ SS
SSS10Z	Set screw, ¼-20 x ¼ SS

INSTRUCTIONS FOR MOUNTING NEW 1-PIECE NORD GEAR REDUCER/GEAR MOTOR

1. **Disconnect and unplug from main power source and perform lockout/tagout before attempting to service.**
2. Remove rear cover.
3. Remove junction box cover from 1HP motor, disconnect the lead wires from the mixer motor. Loosen the strain relief and pull the cord thru, attach blue ring terminals to black, white, red, and green wires.
4. Remove the paddle assembly from the tub.
5. Remove Item No. SSS10Z, set screw from the end of the mixer drive shaft.
6. Remove Item No. 53516, mixer paddle drive pin from the shaft. Note the position of shims and replace at the same position with new installation.
7. Loosen the two fasteners to the transmission mounting angle and the two fasteners to the transmission and motor mounting bracket. With the help of another person, remove the hex nuts from the four mounting fasteners and remove the mixer transmission and motor assembly. Be careful not to damage tub mixer seal.
8. Attach the new transmission mounting plate, Item No. 57211, to the new gear motor. Use the 7-pc. M8 x 20 hex head cap screws and lock washers supplied (see drawing for reference). Install new mixer drive shaft, Item No. 53955-N with key into the hollow shaft of the gear unit. Secure with large flat washers, lock washer, and hex bolt.
9. With another person, attach the mounting plate with the gear motor onto the existing mounting brackets sliding the mixer drive shaft through the mixer drive seal. Try not to damage the mixer seal. Note the shim position, and use the existing fasteners, ½-13 x 1½ hex cap screws, lock washer, and nuts to secure.
10. Insert the mixer paddle drive pin, Item No. 53516. Tighten the set screw, Item No. SSS10Z.
11. Place the mixer paddle assembly back in the hopper and onto the mixer drive shaft.
12. Assemble the lock arm assembly, Item No. 53852, onto the front of the hopper on the paddle assembly.
13. Be sure the transmission mounting plate is tight to the mounting brackets.
14. Does the lock arm assembly turn free with the paddle assembly? If there were shims on the old mixer transmission assembly to the mounting brackets, you will need to use them again to align the lock arm assembly with the paddle assembly.
15. Re-attach the electrical cord. Tighten the strain relief on the cord. Be sure all other electrical connections are tight.
CAUTION – BE SURE the motor is connected for the proper voltage – check the arrangement of the jumper straps in the motor junction box.
16. Plug in the mixer-grinder to power.
17. Check the rotation to the mixer paddle assembly. The direction of the mixer paddle assembly is counter clockwise. If the rotation is clockwise, switch two of the three wires to the mixer motor. Check rotation again for the mixer paddle assembly. The rotation for the mixer paddle and the auger are both counter-clockwise.
18. Reattach the motor junction box cover.
19. Attach rear cover.

KIT, Item #57212K consists of:

1 pc.	57212	NORD GEAR-MOTOR REDUCER, 1¾HP	1 pc.	HHS125S	HEX HEAD SCREW ½-13 x 1 SS
3 pcs.	50668	E50 OVERLOAD HEATER ELEMENTS	1 pc.	LW 30S	LOCK WASHER ½ SS
1 pc.	57211	TRANSMISSION MOUNTING PLATE	41"	35220	MOTOR CORD, 14 ga. x 4 WIRE, TYPE SO
1 pc.	53955-N	MIXER DRIVE SHAFT FOR NORD	2 pcs.	53511	CORD CONNECTOR
1 pc.	53953	MIXER DRIVE SHAFT SEAL	4 pcs.	1773-1	RING, TERMINAL #10, 16-14AWG, insulated
1 pc.	53953A-1	LOCTITE ADHESIVE FOR SHAFT SEAL	7 pcs.	HHSM059S	HEX HEAD SCREW, M8 x 1.25 x 20MM SS
1 pc.	53516	MIXER PADDLE DRIVE PIN	7 pcs.	LW15S	LOCK WASHER 5/16 SS
1 pc.	SSS10Z	SET SCREW FOR DRIVE PIN ¼-20 x ¼			
1 pc.	53769-35	KEY FOR MIXER DRIVE SHAFT			
1 pc.	53769-47	WASHER RETAINER FOR MIXER SHAFT			

4. **FOR DORRIS MIXER TRANSMISSION (OBSOLETE -N/A) BEFORE SERIAL NO. 55665**

DORRIS MIXER TRANSMISSION: Oil in the mixer transmission should be changed after the first four (4) weeks of operation. This is to remove the "run-in" oil and also any small metal shavings that may have been generated during the initial mating of the gears. After the first oil change, subsequent changes should be performed every six (6) months. After draining the oil, refill the unit to the "level" plug (1 qt.) at the center of the transmission with a petroleum based rust and oxidation (R&O) inhibited gear oil. Viscosity Range for 15-75 degrees F (-9 – 24 degrees C) is AGMA Lube No. 3 or ISO Grade 100.

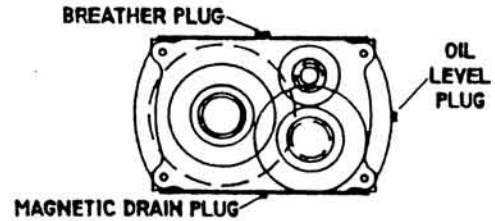

**SUGGESTED POPULAR NAME BRANDS:
R & O GEAR OILS
(RUST & OXIDATION INHIBITED)**

TO CHANGE OIL:

- a. Unplug mixer/grinder from power source and perform lockout/tagout procedures.
- b. Remove rear drive cover.
- c. Remove breather plug from top of transmission and oil level plug from side of transmission
- d. With a container in place to catch old oil, remove the magnetic drain plug from the bottom of the transmission.
- e. When all oil has drained, clean the drain plug and replace into the transmission.
- f. Refill transmission with approx. one (1) quart of the recommended gear oils or equivalent. Or until oil appears at bottom of oil level sight hole.
- g. Replace breather and oil level plugs.
- h. Carefully turn mixer transmission pulley by hand to lubricate internal gears.
- i. Reinstall rear drive cover.

COMPANY	ISO VISCOSITY GRADE 100 (AGMA3)
AMOCO	American Ind'l Oil 100
CHEVRON	Machine Oil \$ & O ISO 100
CITGO	Pacemaker Oil 100
CONOCO	Dectol R & O Oil 100
EXXON	Teresstic 100
MOBIL	DTE Heavy
PHILLIPS	Magnus Oil ISO VG 100
SHELL	Morlina Oil 100
SUN	Sunvis 9100
TEXACO	Regal Oil R & O 100

D. MIXER DRIVE BELT TENSION

1. Unplug mixer/grinder from power source and perform lockout/tagout procedures.
2. Remove rear drive cover.
3. Loosen the four bolts holding the 1HP motor to its mounting plate.
4. Slide 1HP motor away from mixer transmission.
5. When approximately 1/2" total belt flex has been attained, retighten motor bolts.
6. Reinstall rear drive cover.

E. MAIN DRIVE CHAIN AND SPROCKET LUBRICATION:

The main drive chain has been pre-lubricated at the factory to protect it against dirt and moisture. Chain life will vary appreciably depending upon its lubrication. The better the lubrication, the longer the chain life.

Lubrication effectiveness will vary with the amount of lubricant and frequency of application. Ideally, a lubricant film should always be present between the working parts. Manually lubricate the chain as often as **is needed** (possibly once a week). **NEVER** exceed three months without lubricating.

Lubricating just the outside of the chain does little good. Apply lubrication on the inside of the chain span so that it will work through the moving parts and joints by centrifugal force as the chain rotates and reach the area where one surface "scrubs" another.

MAIN DRIVE CHAIN AND SPROCKETS LUBRICATION (continued):

Recommended types of chain lubricant are those with Molybdenum Disulphide or Graphite added. Also bonded lubricants such as Dow Corning Molykote 321R or equivalent are excellent for open chains. The lubricant should be of a viscosity whereby it will "flow" somewhat and penetrate the internal working surfaces. Thick stiff greases are of little value because they cannot work into moving parts of the chain.

- Unplug mixer/grinder from power source and perform lockout/tagout procedures.
- Remove rear drive cover.
- Spray or brush lubricant on inside of chain, slowly and carefully turning large sprocket by hand.
- Reinstall rear drive cover.

F. MAIN DRIVE CHAIN TENSION (See Diagram Below)

- Unplug mixer/grinder from power source and perform lockout/tagout procedures.
- Remove rear drive cover.
- Remove right and left side skirts.
- Loosen the four bolts that hold the motor to the frame of the machine.
- Loosen the lock nuts on the motor adjusting stud.
- To Loosen Chain Tension.** Turn motor adjusting studs counterclockwise. Grasp motor and pull toward adjusting stud. Be sure to turn both adjusting studs the same amount and evenly. Total chain flex should be $\frac{1}{8}$ " to $\frac{3}{8}$ ". Be sure to keep motor shaft **parallel** with auger drive shaft.

To Tighten Chain Tension. Turn motor adjusting studs clockwise. Be sure to turn both adjusting studs the same amount and evenly. Total chain flex should be $\frac{1}{8}$ " to $\frac{3}{8}$ ". Do not overtighten chain as this will put excessive and damaging pressure on the motor bearings. Be sure to keep motor shaft **parallel** with auger drive shaft.

- Retighten motor mounting bolts.
- Retighten motor adjusting stud lock nuts.
- Reinstall the right and left side skirts.
- Reinstall the rear drive cover.

**AFTER INSTALLATION
THE CHAIN SHOULD BE
TENSIONED TO
APPROXIMATELY
 $\frac{1}{8}$ to $\frac{3}{8}$ FLEX**

SPRING CLIP

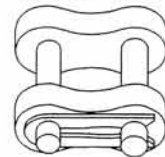

G. CHAIN REPLACEMENT

- Part No. H384-CL Service Replacement Chain is provided with a "Connecting Link" (Part No. H384-LINK) so that it can be separated to facilitate installation over the sprockets

Upon assembly, be sure the connecting link is installed so the spring clip is orientated with its opening facing "opposite" the direction of the chain travel (See Diagram). →

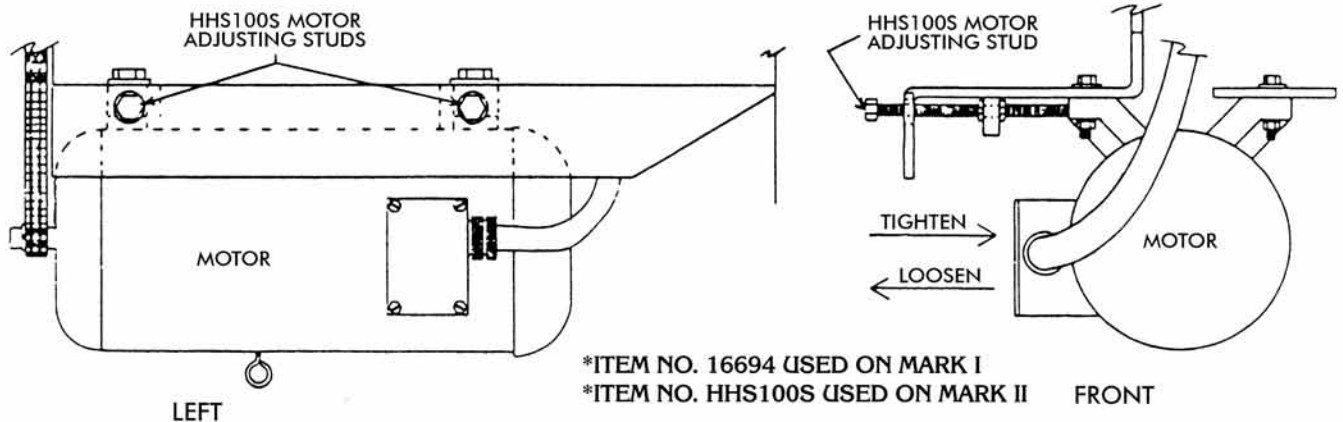

INSTALLATION NOTES:

- INCOMING WIRE SIZE - A.W.G. 10 GA.(7-1/2 H.P.)/8 GA. (10 H.P.)
- DEPENDENT ON N.E.C. AND LOCAL CODE
- EXTERNAL GROUND PER N.E.C. ARTICLE 250
- ROTATION OF MIXER & GRINDER - COUNTER CLOCKWISE
- FACING PRODUCT DISCHARGE IF ROTATION IS REVERSED -
- INTERCHANGE ANY -TWO- POWER LEADS

NOTE: DPDT SWITCH CONTACTS 'MAKE' OPPOSITE OF TOGGLE POSITION. ALL CONTROLS & NOMENCLATURE AS VIEWED FROM OPERATING SIDE OF LEGEND PLATE. ALL CONTACTS SHOWN IN 'OFF' POSITION & 'HAND' MODE OF OPERATION.

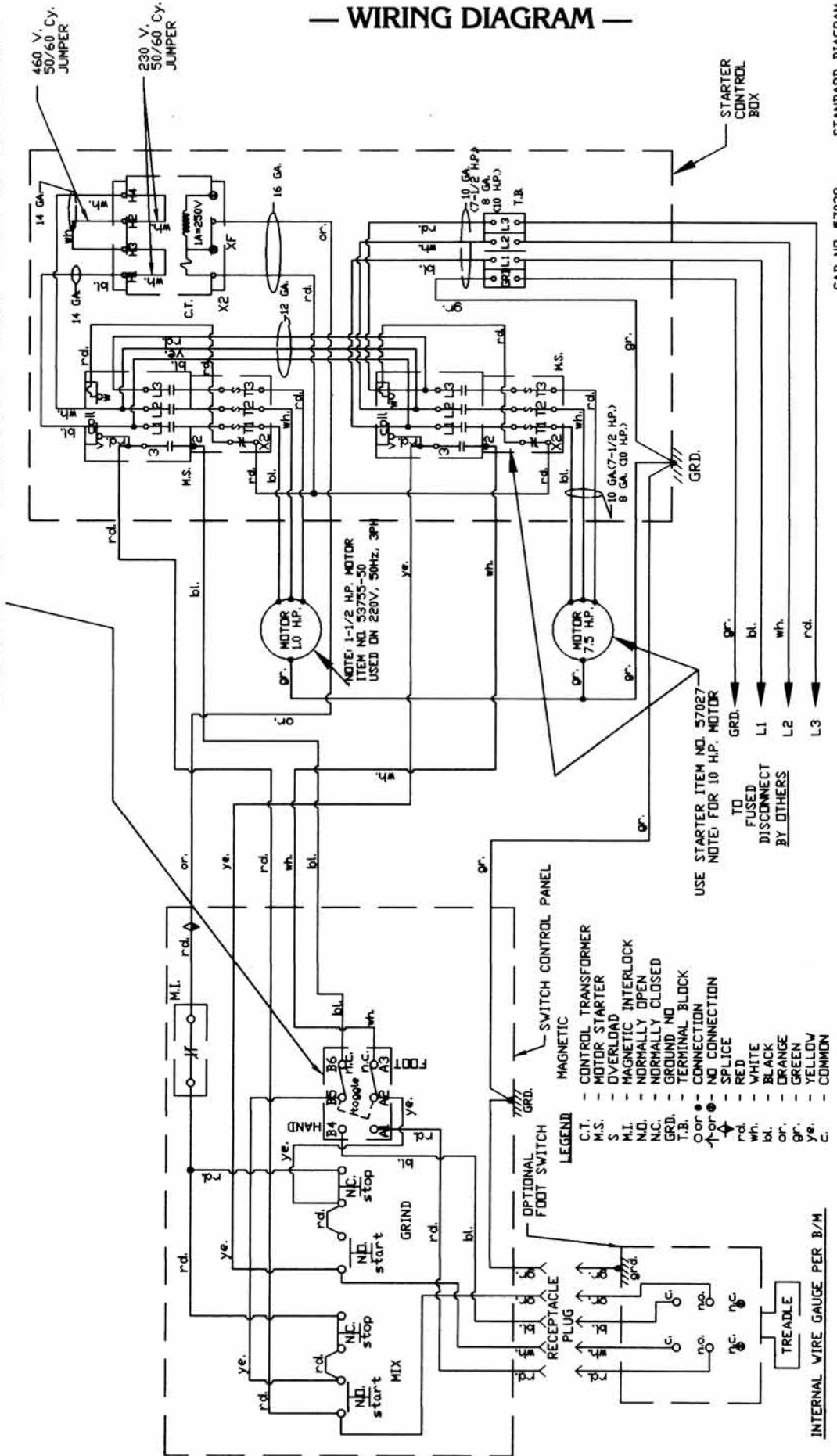

— NOTES —

AFMG-52 SIDE VIEW PARTS DIAGRAM

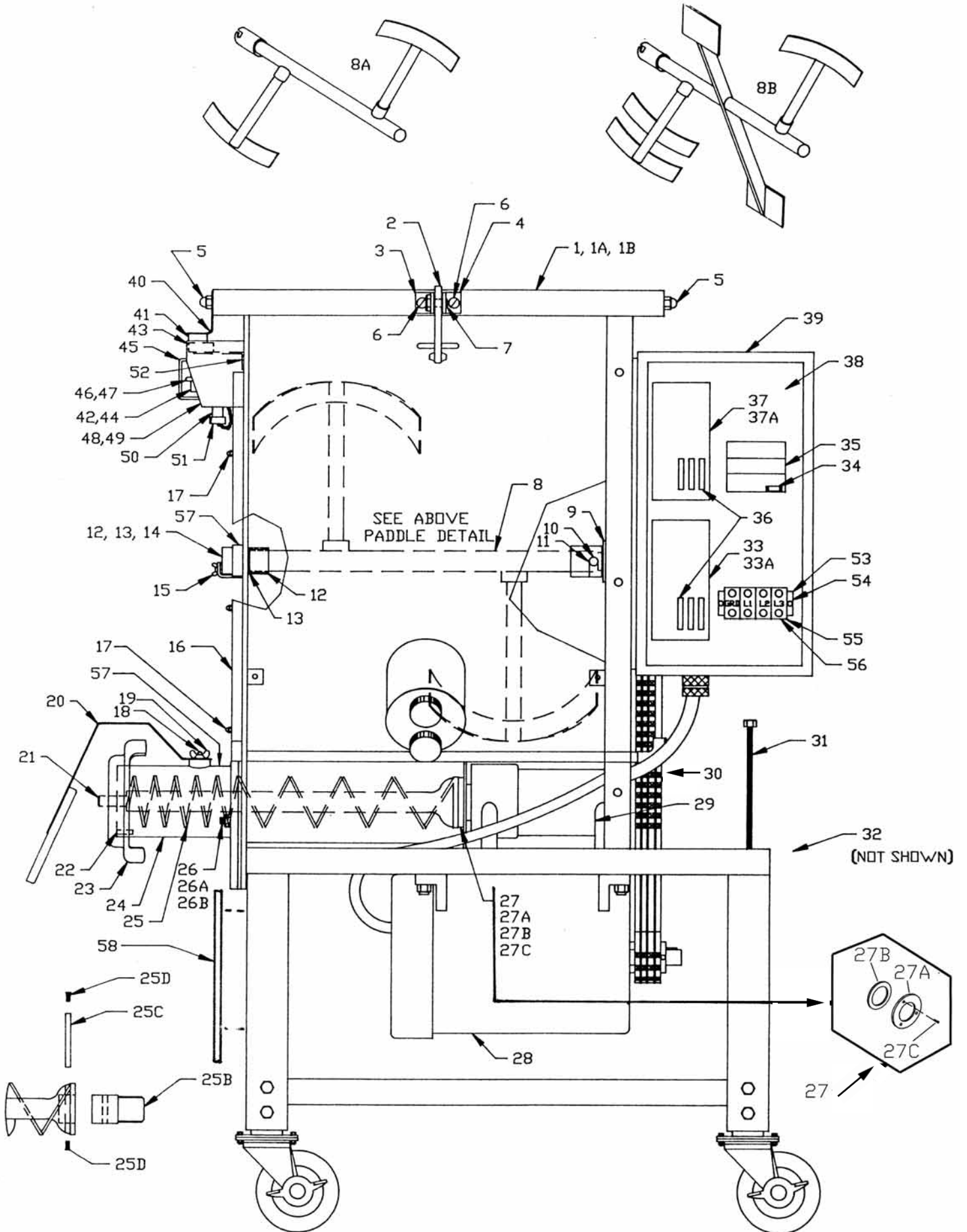

BIRO MODEL AFMG-52 MIXER GRINDER PARTS LIST

Fig.	Item No.	Description	Fig.	Item No.	Description
1	57154	Product mixer safety cover, tri directional, #52345 on		HHS055S	Hex head screw $\frac{5}{16}$ -18 x $\frac{3}{4}$, SS
1A	53547	Lid with chute opening		HN07S	Hex nut 10-24, SS
1B	53543	Conveyor chute		HN15S	Hex nut $\frac{1}{4}$ -20, SS
2	56072	Safety cover latch		HN20S	Hex nut $\frac{5}{16}$ -18, SS
3	56073	Safety cover latch mounting bracket, L.H.		LW10S	Lock washer $\frac{1}{4}$, SS
4	56074	Safety cover latch mounting bracket, R.H.	33	LWE10P	Lock washer #10 ext tooth, SS
5	AN20S	Acorn nut, $\frac{3}{8}$ -16 (2 req.)		53478	Starter w/110V coil, Furnas size 1, 14DP32AF81, $7\frac{1}{2}$ HP
6	RHS24S	Round head screw, $\frac{1}{4}$ -20 x $\frac{1}{2}$ (2 req.)		55046	Starter w/24V coil, Furnas size 1, 14DP32AJ71, $7\frac{1}{2}$ HP
	HNNL15S	Hex nut, nylok, $\frac{1}{4}$ -20 (2 req.)		75DF14	Contact kit, Furnas 1 pole only (size 1) $7\frac{1}{2}$ HP
7	RHS31S	Round head screw, $\frac{1}{4}$ -20 x 1		57027	Starter w/110V coil, Furnas size $1\frac{3}{4}$, 14EP32AF81, 10HP
	HNNL15S	Hex nut, nylok, $\frac{1}{4}$ -20		57027CE	Starter w/24V coil, Furnas size $1\frac{3}{4}$, 14EP32AJ71, 10HP
8A	53456	Mixer paddle assembly, 1st grind, optional		75EF14	Contact kit, Furnas 1 pole only (size $1\frac{3}{4}$) 10HP
8B	53918	Mixer paddle assembly, 2nd grind, standard	33A	34478	Holding coil - 120V/240V
9	53953	Mixer drive shaft seal		55047	Holding coil - 24V
10	53516	Mixer paddle drive pin	34	53851	Fuse, FNM-1 AMP, 250V timedelay
11	SSS10Z	Drive pin set screw	35	53914	Transformer, 230/460 to 115V
12	53594	Bearing for 53520 assembly		53731	Transformer, 575 to 115V
13	53517-1	Thrust bearing		PC141-1	Transformer replacement, 200/208/220/240/277/380 to 24V
14	53852	Lock arm assembly w/brgs.	36		See electrical diagram, page 4
15	53568	Mixer paddle lock set screw	37	53477	Starter w/110V coil, Furnas size 00, 14BP32AF81, $1\frac{3}{4}$ HP
16	57047	Wireway cover, #52101 on		55045	Starter w/24V coil, Furnas size 00, 14BG32AJ71, 1HP
17	1116	Acorn nut, 10-32 (3 req.)		75BF14	Contact kit, Furnas 1 pole only (size 00) 1HP
18	SSS45S	Meatguard mounting stud	37A	34478	Holding coil - 120V/240V
19	WN20S	Wing nut		55047	Holding coil - 24V
20	52392	Meat guard splash shield	38	53633	Starter box cover
21	HK52/56	Knife drive pin	39	53860	Starter box
22	HP52	Bowl plate pin (3 req.)	40	52181-1	Magnetic switch bracket for magnet
23	HR52	Bowl ring	41	52181-1	Magnet w/mounting brkt. (110 volt)
24	57023-CTN	Bowl w/plate pins		PC166	Magnetic safety switch (24 volt) old style units only (not CE)
25	57022-CTN	Auger assembly	42	42MC-Y73	Green start control
25B	54278B	Square drive auger adapter	43	H442-1	Magni switch, 3 amp
25C	54278C	Auger shear pin		53872	Safety switch mounting bracket
25D	FHS36S	Shear pin flat head screw, $\frac{1}{4}$ -20 x 1	44	42MC-Y74	Red stop control
26	53413	Bowl mounting stud - short (1 req.)	45	50655-1	Switch guard
	HNF42S	Hex flange nut, $\frac{1}{2}$ -13, (2 req.)		H462-1	Switch guard ferrule
26A	53413-2	Bowl mounting stud - long (2 req.)		HN20S	Hex nut $\frac{5}{16}$ -18 SS
26B	HNF42S	Hex flange nut $\frac{1}{2}$ -13 bowl mounting nut (3 req.)		LW15S	Lock washer $\frac{5}{16}$ SS
27	57159K	Auger drive shaft seal kit	46	54320K	Toggle switch, hand/foot, w/boot
27A	57160	Seal retainer, SS	47	54321	Toggle switch waterproof half boot
27B	57159	Auger drive shaft seal, double lip	48	53869CEK	Legend plate, w/int'l. symbols, int'l kit
27C	FHS26S	Flat head screw 10-32 x $\frac{3}{4}$, SS	49	53870	Legend plate gasket
28	53475-200	Motor, $7\frac{1}{2}$ HP, 200/400-60-3	50	52655	Female receptacle, 5 pole, for footswitch
	53475	Motor, $7\frac{1}{2}$ HP, 208/460-60-3	51	52662	Protective cap assembly
	53475-50	Motor, $7\frac{1}{2}$ HP, 208/380-50-3	52	53872	Safety switch bracket
	53941	Motor, $7\frac{1}{2}$ HP, 575-60-3	53	35376	End anchor
	53475-1	Baldor $7\frac{1}{2}$ HP, bearing both ends - 206KDD	54	35241	Mounting channel
	53475-2	Doerr $7\frac{1}{2}$ HP, bearing, opp. shaft - 206KDD	55	35375	End barrier
	53475-3	Doerr $7\frac{1}{2}$ HP, bearing, shaft end - 207KDD	56	35374	Terminal block
	57025-200	Motor, 10HP, 200/400-60-3	57	53783	Decal, rotation
	57025	Motor, 10HP, 208/460-50/60-3	58	57157	Front splash shield
	57025-5	Motor, 10HP, 575-60-3		HHS025S	Hex head screw $\frac{1}{4}$ -20 x $\frac{1}{2}$, SS
	57092	Motor, 10HP, 220/380-50-3		HN15S	Hex nut $\frac{1}{4}$ -20, SS
29	53886	Journal box assembly		LW10S	Lock washer $\frac{1}{4}$, SS
30	H384-CL	Roller chain			
31	54310	Adjusting stud			
32	55092	Rear drive cover w/handles			
	55092-COSK	Rear drive cover COS kit			
	55092-COS	Rear drive cover w/handles & magnet			
	14688	4-point knob, AL			
	14688-COS	Locking knob, AL, 8 Req			
	57219	Screw - COS rear drive cover, 8 Req			
	FW05S	Flat washer $\frac{1}{4}$, SS			
	FW16S	Flat washer $\frac{5}{16}$, SS			
	HHS025S	Hex head screw $\frac{1}{4}$ -20 x $\frac{1}{2}$, SS			
	HHS049S	Hex head screw $\frac{3}{16}$ -18 x $\frac{1}{2}$, SS			
	HHS050S	Hex head screw $\frac{3}{16}$ -18 x $\frac{5}{8}$, SS			
				NOT SHOWN	
				57073	Power cord, 10', 8-4
				54268	Power cord, 10', 10-4
				2563	Legend plate hex screw 10-32 x $\frac{1}{2}$, SS
				53965	Optional leg ext. kit with brace

**AFMG-52 MIXER GRINDER
PARTS LIST WITH NORD
GEAR TRANSMISSION
STARTING WITH
SERIAL No. 55665**

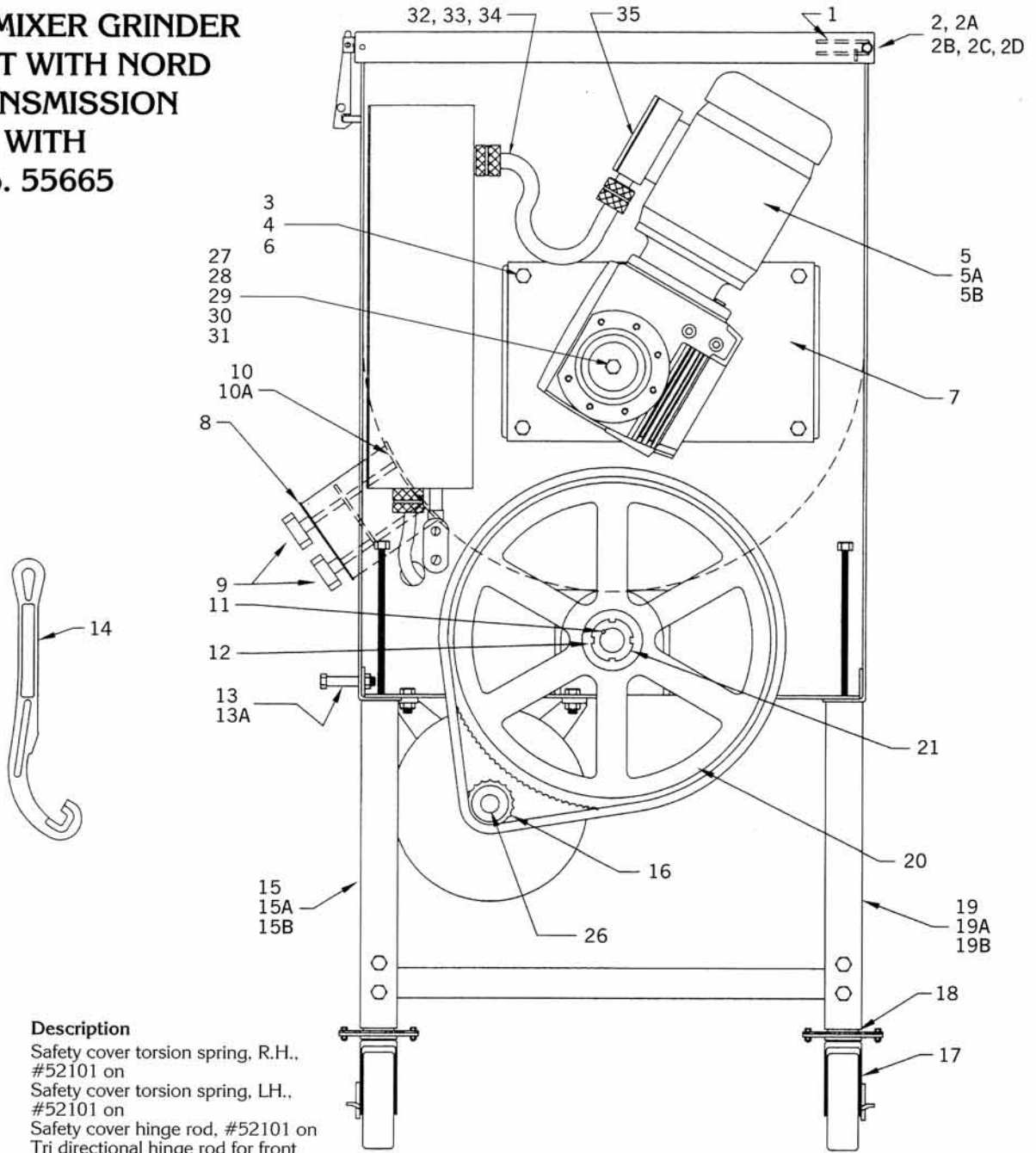
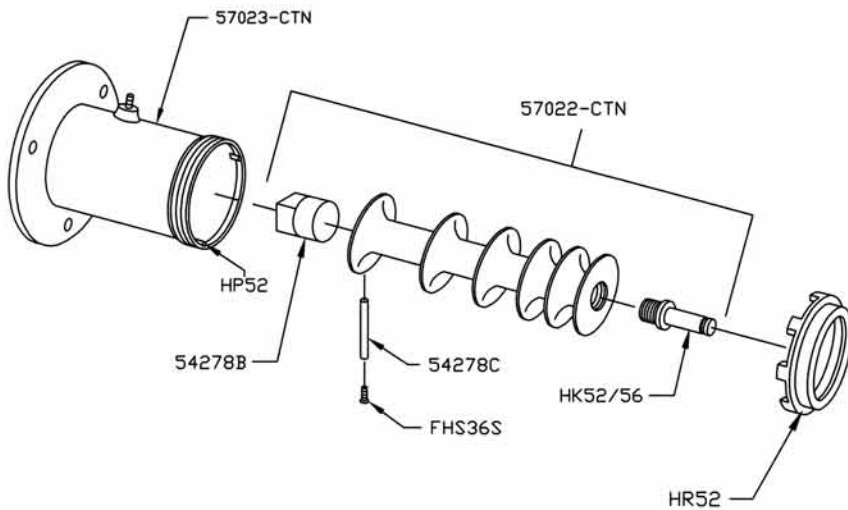

Fig.	Item No.	Description	Fig.	Item No.	Description
1	56221	Safety cover torsion spring, R.H., #52101 on	15A	55094	Right side skirt – no hole
	56222	Safety cover torsion spring, L.H., #52101 on		15B	55095
2 2A	57050	Safety cover hinge rod, #52101 on	16	53580	Sprocket, 22 tooth, (order H382-1)
	57153	Tri directional hinge rod for front opening, #52345 on 27 3/4 Long		H382	Sprocket, 19 tooth (replacement only)
2B	56045	Hinge rod spacer (2 req'd)	17	PC175-1	Swivel caster w/total lock, (4 req.) – new style
	AN20S	Acorn nut 3/8-16, SS (2 req'd)		53952	Swivel caster w/lock, (4 req.) – old style
2C	57050	Safety Cover Hinge Rod for Side Opening 25 5/16 Long	18	53944-1	Standard leg, 9 1/2" adjusting – new style caster pad
	57050	Safety Cover Hinge Rod for Side Opening 25 5/16 Long		53944	Standard leg, 9 1/2" adjusting – old style caster pad
3	HHS127S	Hex head screw, 1/2-13 x 1 1/2 SS	19	53944-5K	Foot leg pad bumper kit (4 ea.)
	LW30S	Lock washer, 1/2 SS		55096	Left side skirt – 35° inlet
4	57212	Motor & reducer only – Nord 1 3/4HP, 208-220-230/380-415-460/50-60/3Ph	19A	55097	Left side skirt – no hole
	57212-1	Motor & reducer only – Nord 1 3/4HP, 200/60-3Ph		55098	Left side skirt, 90° inlet
5A	57212-2	Motor & reducer only – Nord 1 3/4HP, 550-575V-50/60-3Ph	20	53727	Main sprocket
	57212-2	Motor & reducer only – Nord 1 3/4HP, 550-575V-50/60-3Ph		21	53895
6	HN42S	Hex nut, 13 SS	26		C617
	57211	Mounting plate		53955-N	Mixer drive shaft
7	54303	Outer disc, double rod, #52001 on	27	53769-35	Mixer drive shaft key
	14688	Lock knob, (2 req.)		53769-47	Mixer shaft washer retainer
8	57133	Side entrance seal, double rod, 35° inlet, #52345 on	30	HHS125S	Hex head screw, 1/2-13 x 1 SS
	54302	Side entrance seal, double rod, 90° inlet, #52001 to #52344		31	LW30S
10A	53891	Auger drive shaft key	32		35220
	53894	Auger drive shaft lockwasher		33	53511
11	53715-1	Ring wrench hanger	34		1773-1
	HN15S	Hex nut 1/4-20, SS		35	C776
13A	52357	Ring wrench (order H340)			
	15	55093	Right side skirt, 35° inlet, #52345 on		

**STANDARD "ENTERPRISE" BOWL ASSEMBLY
(SINGLE KNIFE & SINGLE PLATE)**



<u>ITEM NO.</u>	<u>DESCRIPTION</u>
54278B	Square Drive Auger Adapter
54278C	Auger Shear Pin
57022-CTN	Auger Assembly
57023-CTN	Bowl w/Plate Pins
FHS36S	Shear Pin Fastener 1/4-20 x 1 SS
HK52/56	Knife Drive Pin
HP52	Bowl Plate Pin (3 req.)
HR52	Bowl Ring

**OPTIONAL "ENTERPRISE" SIZE 52
SINGLE KNIFE & SINGLE PLATE**

<u>ITEM NO.</u>	<u>DESCRIPTION</u>
MC52-17	Knife, 4 Blade
MC52-18-125	Plate, 1/8" Holes (3.5 mm)
MC-52-18-156	Plate, 5/32" Holes (4.0 mm)
MC52-18-187	Plate, 3/16" Holes (5.0 mm)
MC52-18-375	Plate, 3/8" Holes (9.0 mm)

**OPTIONAL STAINLESS STEEL "ENTERPRISE" BOWL ASSEMBLY
(SINGLE KNIFE & SINGLE PLATE)**

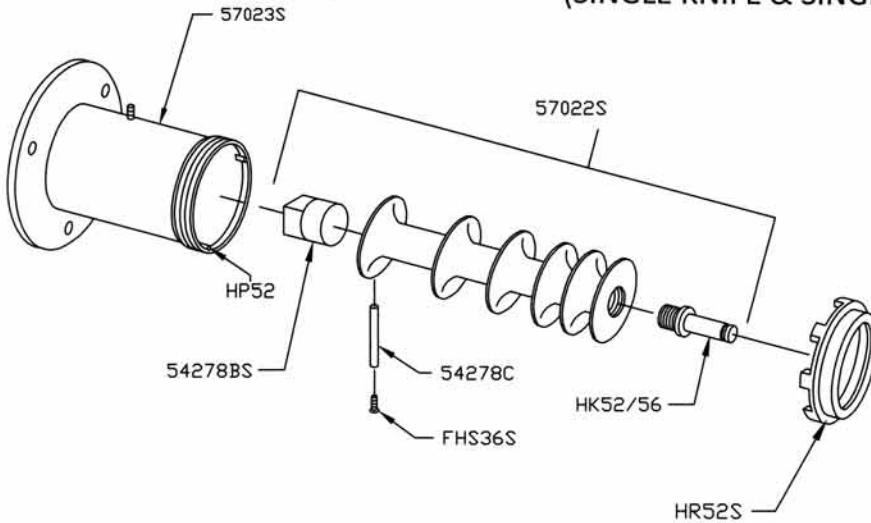

<u>ITEM NO.</u>	<u>DESCRIPTION</u>
54278BS	Square Drive Auger Adapter, SS
54278C	Auger Shear Pin
57022S	Auger Assembly, SS
57023S	Bowl w/Plate Pins, SS
FHS36S	Shear Pin Fastener 1/4-20 x 1, SS
HK52/56	Knife Drive Pin
HP52	Bowl Plate Pin (3-req.)
HR52S	Bowl Ring, SS

**OPTIONAL "ENTERPRISE" SIZE 52
SINGLE KNIFE & SINGLE PLATE**

<u>ITEM NO.</u>	<u>DESCRIPTION</u>
MC52-17	Knife, 4 Blade
MC52-18-125	Plate, 1/8" Holes (3.5 mm)
MC-52-18-156	Plate, 5/32" Holes (4.0 mm)
MC52-18-187	Plate, 3/16" Holes (5.0 mm)
MC52-18-375	Plate, 3/8" Holes (9.0 mm)

**OPTIONAL STAINLESS STEEL "UNGER" BOWL ASSEMBLY
(NON-STANDARD MULTI KNIVES & PLATES)**

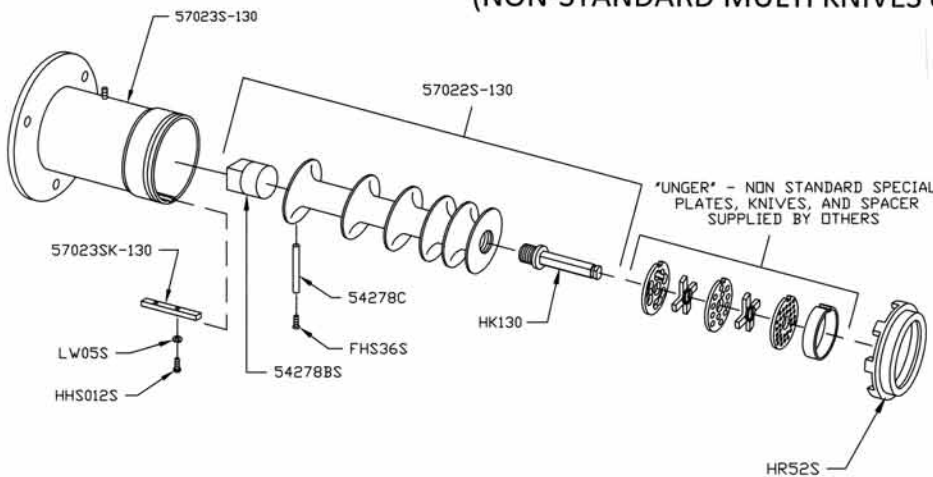

130mm UNGER

<u>ITEM NO.</u>	<u>DESCRIPTION</u>
54278BS	Square Drive Auger Adapter, SS
54278C	Auger Shear Pin
57022S-130	Auger Assembly, SS 130mm Unger
57023S-130	Bowl, SS, 130mm Unger
57023SK-130	Key, 130mm Unger
FHS36S	Shear Pin Fastener 1/4-20 x 1, SS
HHS012S	Hex Head Screw, 10-32 x 1/2, SS
HK130	Knife Drive Pin, 130mm Unger
HR52S	Bowl Ring, SS
LW05S	Lock Washer, #10, SS

PRODUCT MIXER SAFETY COVER UP TO S/N 52100 – FRONT OPENING ONLY

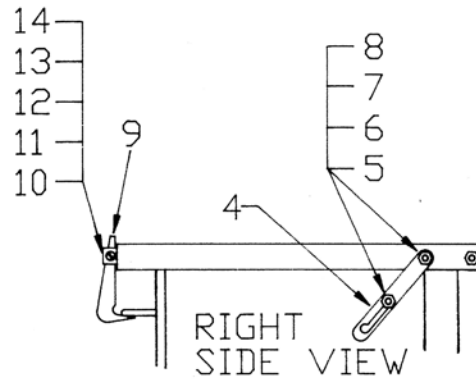
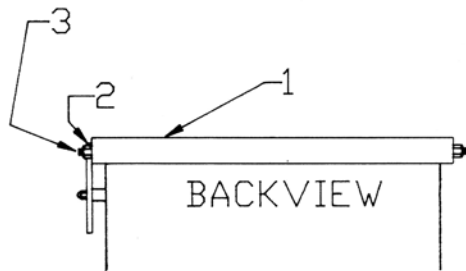
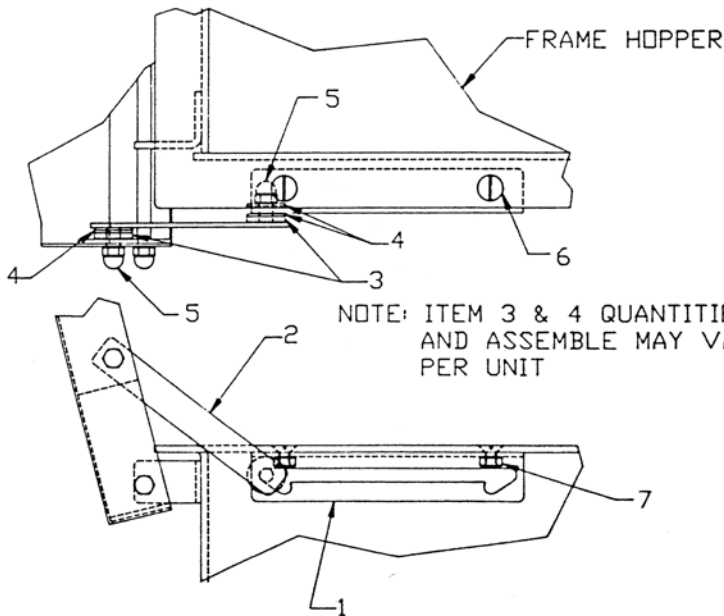

Fig.	Item No.	Description
1	53446	Lid assembly to #52100
2	HN30S	Hex nut, $\frac{3}{8}$ -16, SS (2 ea.)
3	51563	Lid hinge pin to #52100 (2 ea.)
4	53530	Lid lock arm to #52100
5	53533	Lid lock spacers to #52100 (2 ea.)
6	AN15S	Acorn nut, $\frac{1}{4}$ -20, SS (2 ea.)
7	HHS035S	Hex head screw, $\frac{1}{4}$ -20 x $\frac{5}{8}$, SS (2 ea.)

Fig.	Item No.	Description
8	FW05S	Flat washer, $\frac{1}{4}$, SS (2 ea.)
9	56072	Safety cover latch
10	56073	Latch mounting bracket, LH
11	56074	Latch mounting bracket, RH
12	RHS24S	Round head screw, $\frac{1}{4}$ -20 x $\frac{1}{2}$, SS (2 ea.)
13	HNNL15S	Hex nut, $\frac{1}{4}$ -20 nylok (3 ea.)
14	RHS31S	Round head screw, $\frac{1}{4}$ -20 x 1, SS (1 ea.)



**PRODUCT MIXER SAFETY COVER
LID LOCK FEATURE
S/N 54248 ON**

RETROFITS ON S/N 52100 TO S/N 54247

Fig.	Item No.	Description
	55081	Lid lock retrofit kit S/N 52100 to 54247
1	55059	Lid lock
2	55061	Lever arm assembly
3	2503	Nylon washer, .125 thick (2 ea.)
4	2504	Nylon washer, .060 thick (4 ea.)
5	AN17S	Acorn nut, $\frac{5}{16}$ -18, SS (2 ea.)
6	FHS33S	Flat head screw, $\frac{1}{4}$ -20 x $\frac{1}{2}$, SS (2 ea.)
7	HN15S	Hex nut, $\frac{1}{4}$ -20, SS (2 ea.)

No. 53886 JOURNAL BOX ASSEMBLY

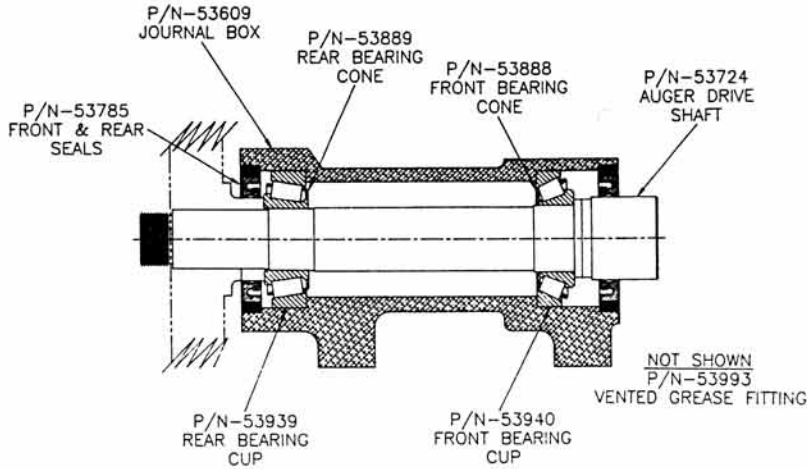

Item No.	Description
53609	Journal box
53724	Auger drive shaft
53785	Journal box seal (2 ea.)
53886	Journal box assembly complete
53888, 53940	Front bearing cup/cone assembly Order H310A
53889, 53939	Rear bearing cup/cone assembly Order H311A
53993	Vented grease fitting

FOOT SWITCH WIRING DIAGRAM

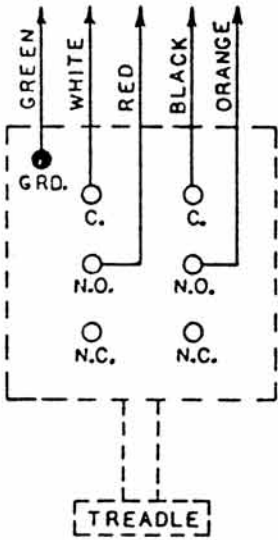

FOOT SWITCH ADJUSTMENT

To change adjustment of the operating point of an interior switch, depress the treadle to the point where you want the switch to operate. With the treadle depressed to the desired operating point, turn the adjusting screw until the switch snaps. Turn clockwise to lower the operating point and counter clockwise to raise it.

FOOT SWITCH WITHOUT COVER

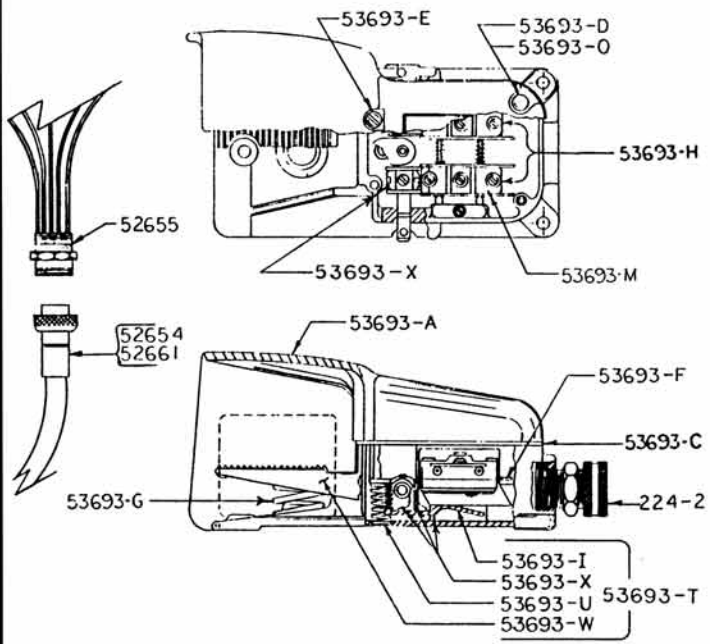
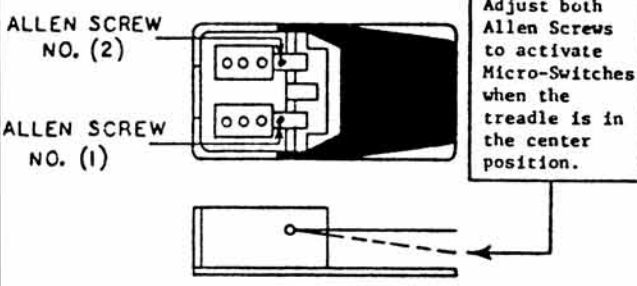

FOOTSWITCH PARTS LIST

224-2	Cord connector, wt, straight, 3/4"
52654	Male plug w/6' cord, 5 wire
52655	Female receptacle, 5 pole
52661	Male plug w/12' cord, 5 wire
52668	Footswitch w/12' cord and plug
53693	Footswitch
53693-A	Cover guard
53693-C	Cover gasket
53693-D	Cover screw - short
53693-E	Cover screw - long
53693-F	Ground screw
53693-G	Treadle spring
53693-H	Internal assembly complete
53693-I	Actuator
53693-M	Micro switch BA-2R62-A4
53693-O	Washer
53693-T	Treadle w/actuator & return spring
53693-U	Auxiliary treadle return spring
53693-W	Treadle
53693-X	One actuator & actuator spring assembly
53979-1	Cord 8' w/o foot switch
54213	Foot switch w/ 6' cord & plug

**ITEMS REQUIRED
FOR TANDEM OPERATION
USED ON ALL UNITS THROUGH 52344**

**BIRO MANUAL TO BIRO AFMG52
BIRO AFMG52 TO BIRO AFMG48
BIRO AFMG52 TO BIRO AFMG52**

**PLEASE NOTE – THESE ARE DESIGNED
TO WORK ON BIRO EQUIPMENT ONLY**

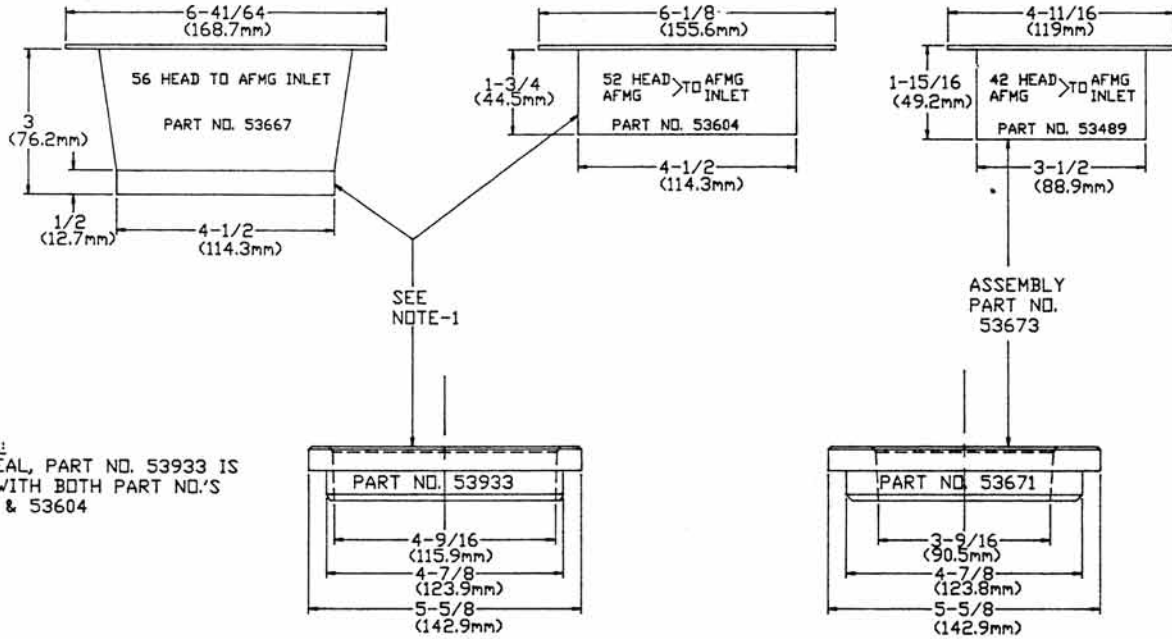

NOTE-1:
THE SEAL, PART NO. 53933 IS
USED WITH BOTH PART NO.'S
53667 & 53604

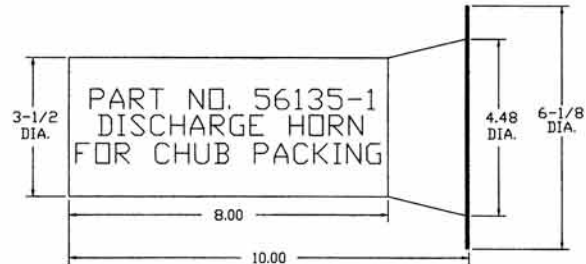
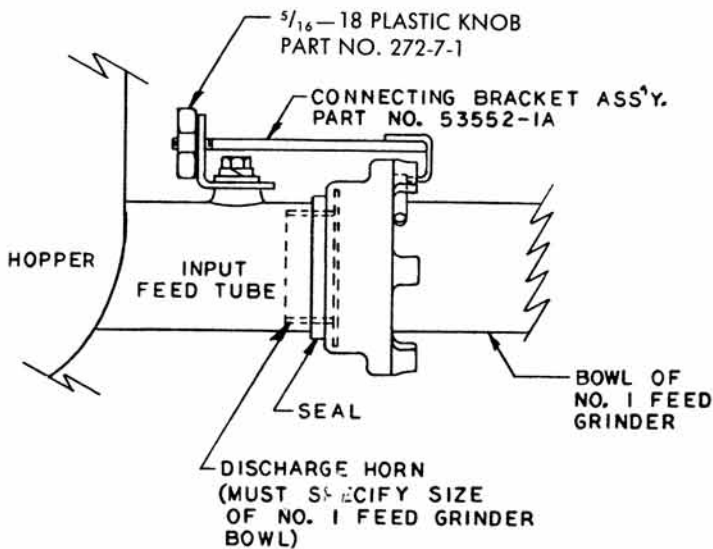

**TANDEM OPERATION
PARTS LIST**

- | | |
|----------|----------------------------------------------------|
| 272-7-1 | 5/16-18 plastic knob, 3 pt. |
| 53489 | Dscg. Horn 24/42/46/48 to 24/48/52 inlet less seal |
| 57044 | Connec. brkt. AFMG52 to AFMG48 |
| 57044 | Connec. brkt. AFMG52 to AFMG52 |
| 53552-1A | Connecting brkt. assem. man/auto |
| 53604 | Dscg. horn 52 to 24/48/52 inlet |
| 53667 | Dscg. horn 56 to 24/48/52 inlet |
| 53671 | Seal only 24/42/46/48 to 24/48/52 inlet |
| 53673 | Disc. horn 48-52 w/seal |
| 53933 | Seal only 52/56 to 24/48/52 inlet |

TANDEM OPERATION ILLUSTRATION FOR 90° INLET

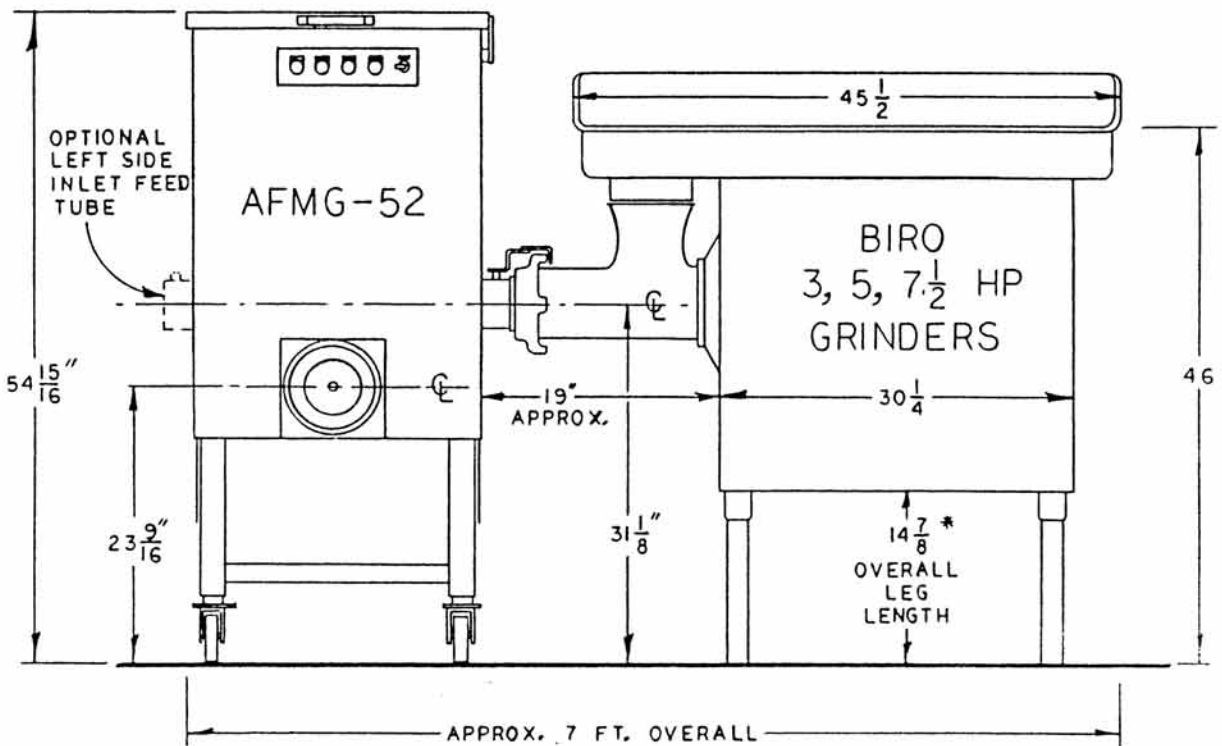
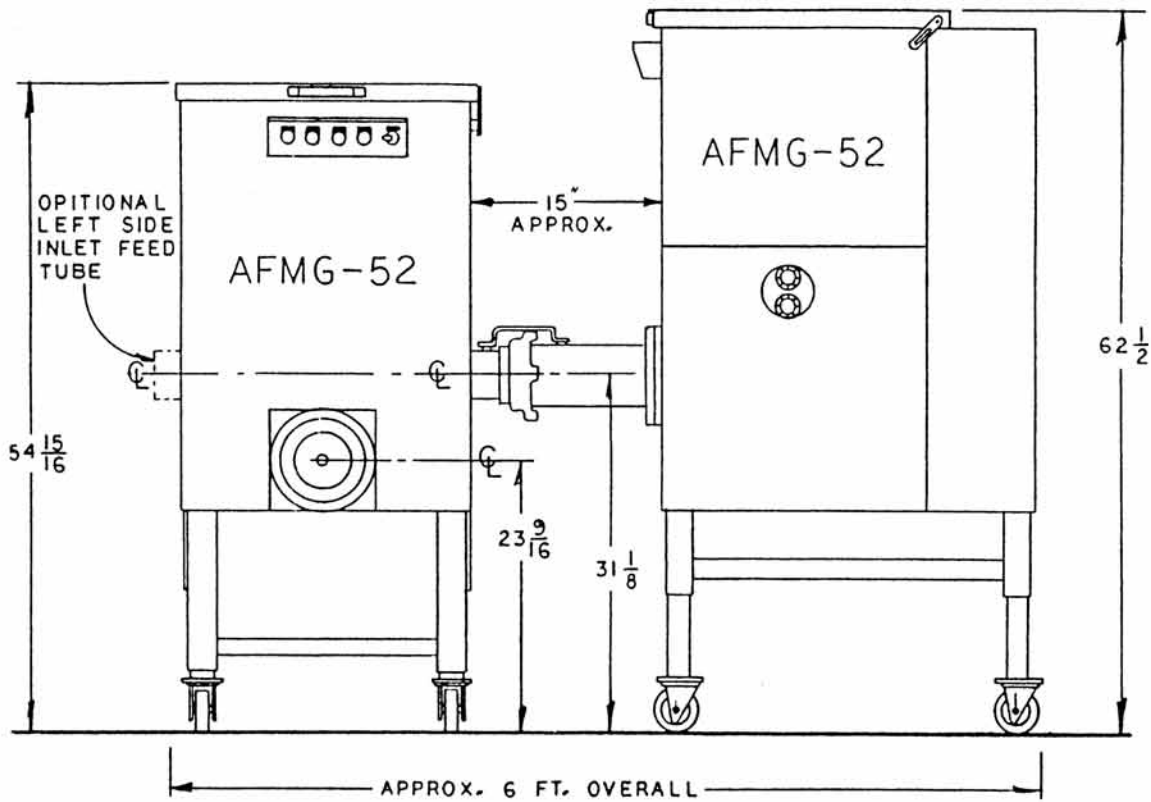

* MODEL 1056 & 1556 OVERALL LEG LENGTH - 10 $\frac{5}{8}$

**ITEMS REQUIRED
FOR 35° TANDEM OPERATION
STARTING WITH SERIAL No. 52345**

**{ BIRO MANUAL TO BIRO AFMG52
BIRO AFMG52 TO BIRO AFMG48
BIRO AFMG52 TO BIRO AFMG52**

**PLEASE NOTE – THESE ARE DESIGNED
TO WORK ON BIRO EQUIPMENT ONLY**

**52 SIZE DISCHARGE HORN ASSEMBLY
Item No. 57143 Includes Clamp Assy.
Item No. 57143-11**

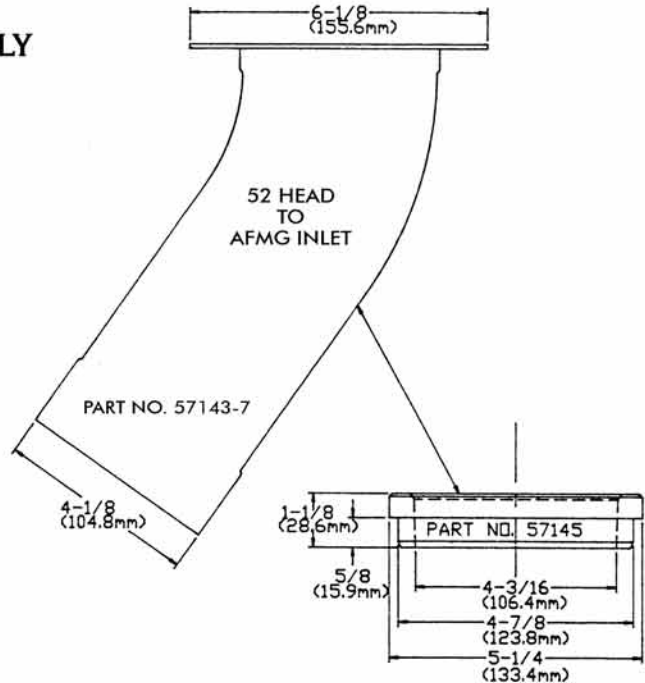
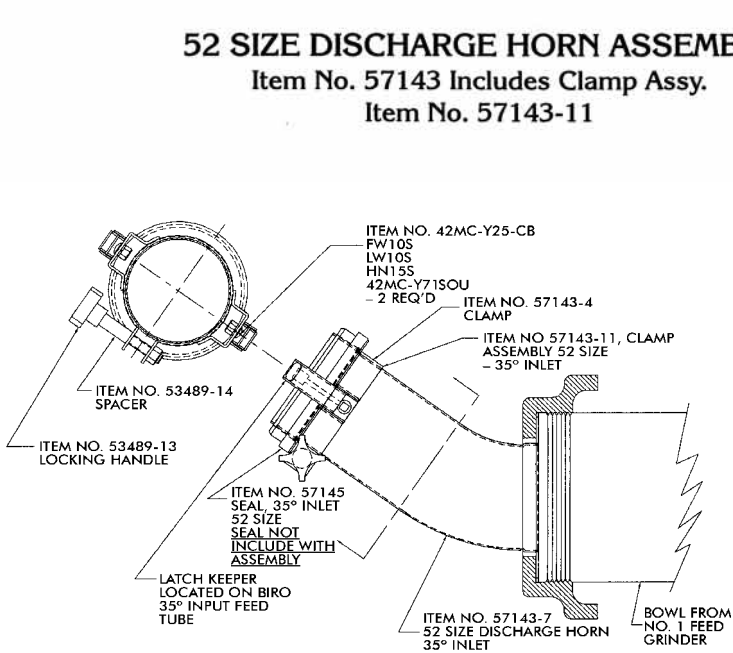

**48 SIZE DISCHARGE HORN ASSEMBLY
Item No. 57144 Includes Clamp Assy.
Item No. 57144-11**

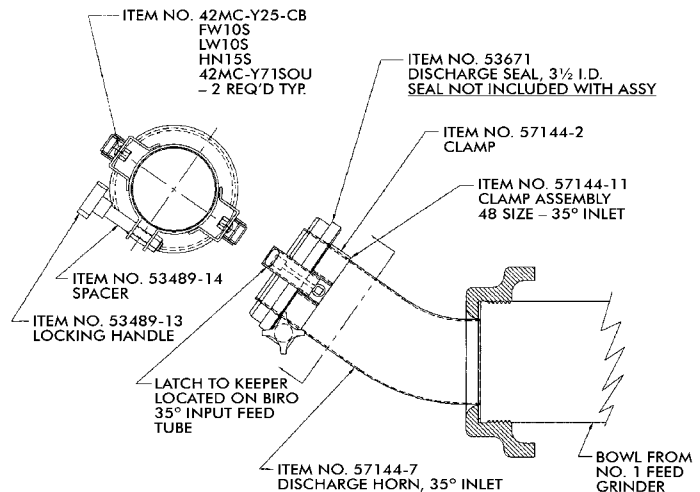
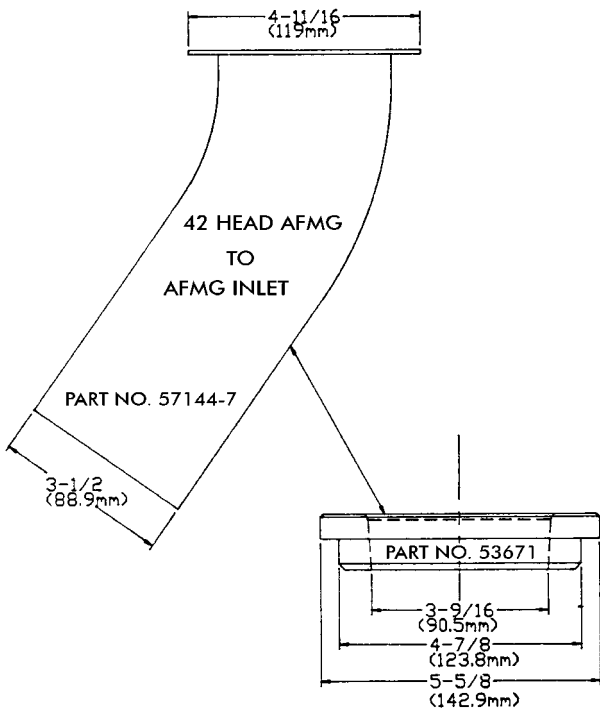

CONNECTION INSTRUCTIONS

TANDEM OPERATIONS

AFMG-48 or AFMG-52 INTO AFMG-48 or AFMG-52 Heavy Horsepower Grinder INTO AFMG-48 or AFMG-52

- Step 1.** Remove Side Entrance Seal, Item No. 57133; Outer Disc, Item No. 54303 and Lock Knobs, Item No. 14688 from the inlet tube of the Second Grind Machine. Clean out the tube if necessary.



- Step 2.** Install the Inlet Tube Seal Item No. 53671 or 57145 into the inlet tube of the Second Grind Machine until fully seated.



- Step 3.** Remove the Ring from the First Grind Machine, Item No. HR42.48 or HR52. Insert the Discharge Horn, Item No. 57144-7 or 57143-7 into the ring. (DO NOT reinstall the ring on the First Grind Machine at this time.) Slide the Clamp Assembly, Item No. 57144-11 or 57143-11 onto the Discharge Horn.



- Step 4.** Insert the Discharge Horn with Ring and Clamp Assembly into the Seal, pushing it fully against the inlet tube internal fins. Attach the lock latches to the tabs on the side of the inlet tube and lock down. Tighten the lock knob on the Clamp Assembly.



- Step 5.** Move the Discharge Horn of the Second Grind Machine up to the Bowl of the First Grind Machine. With the Auger, Knife and Grinding Plate installed in the First Grind Machine, thread the Ring onto the First Grind Machine Bowl. RING SHOULD BE HAND TIGHTENED ONLY: USE NO TOOLS.



TANDEM OPERATION ILLUSTRATION FOR 35° INLET

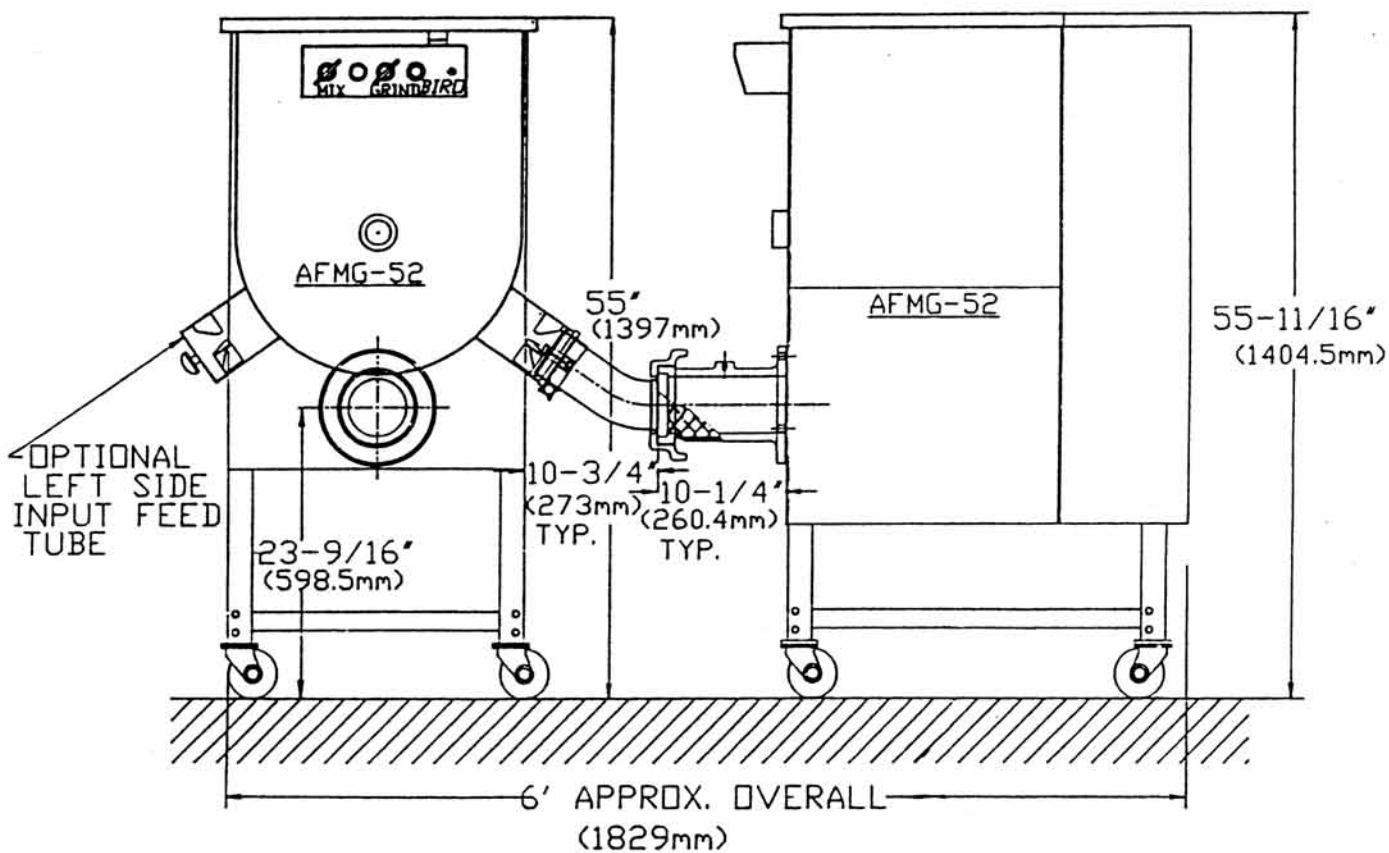

MODEL HHP	
342,548,7548,552,7552	1056,1556
A 11" (279.4mm)	6" (152mm)
B 27-3/8" (695mm)	26-3/4" (679.5mm)
C 55-5/16" (1405mm)	54-11/16" (1389mm)

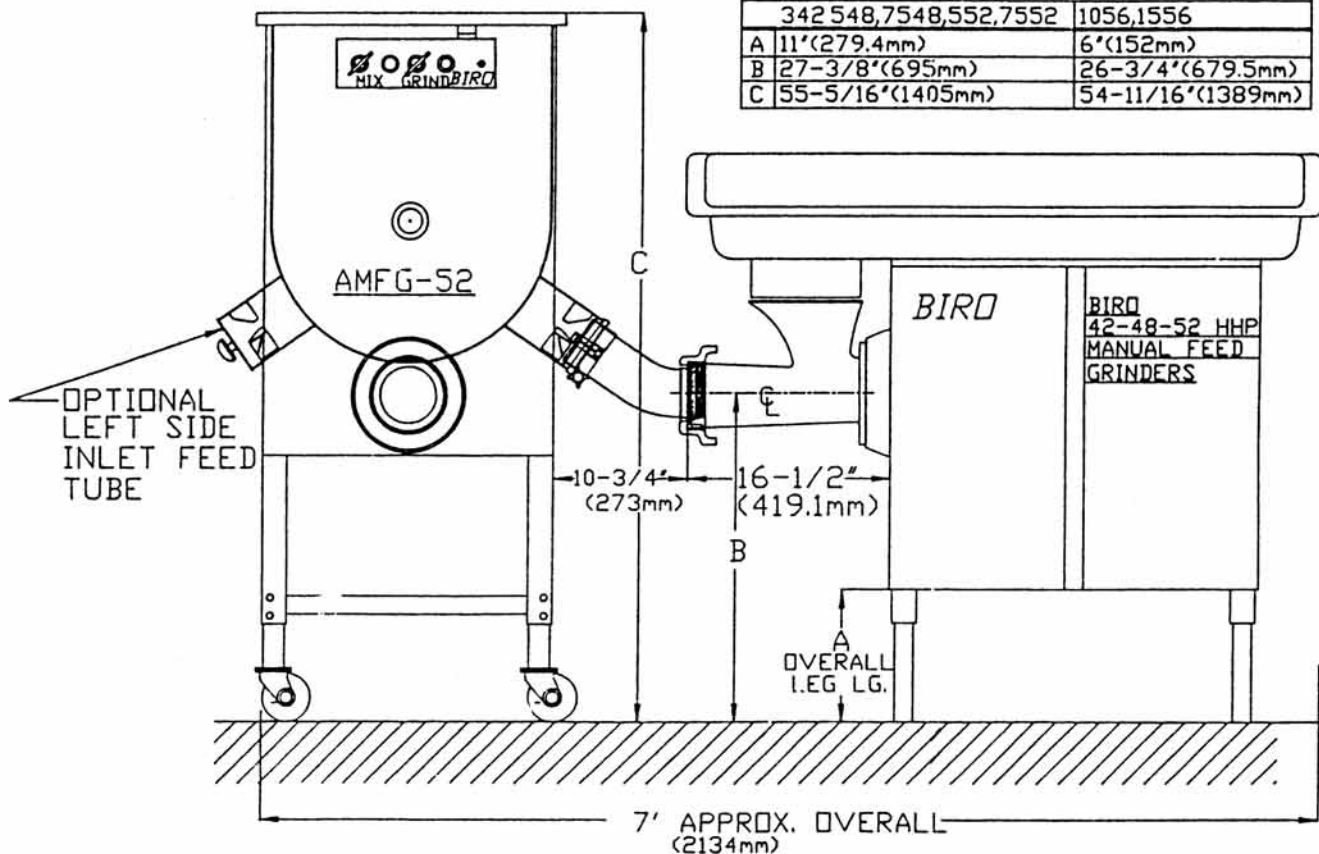

SAFETY LABEL LOCATIONS

CAUTION

KEEP HANDS OUT OF HOPPER

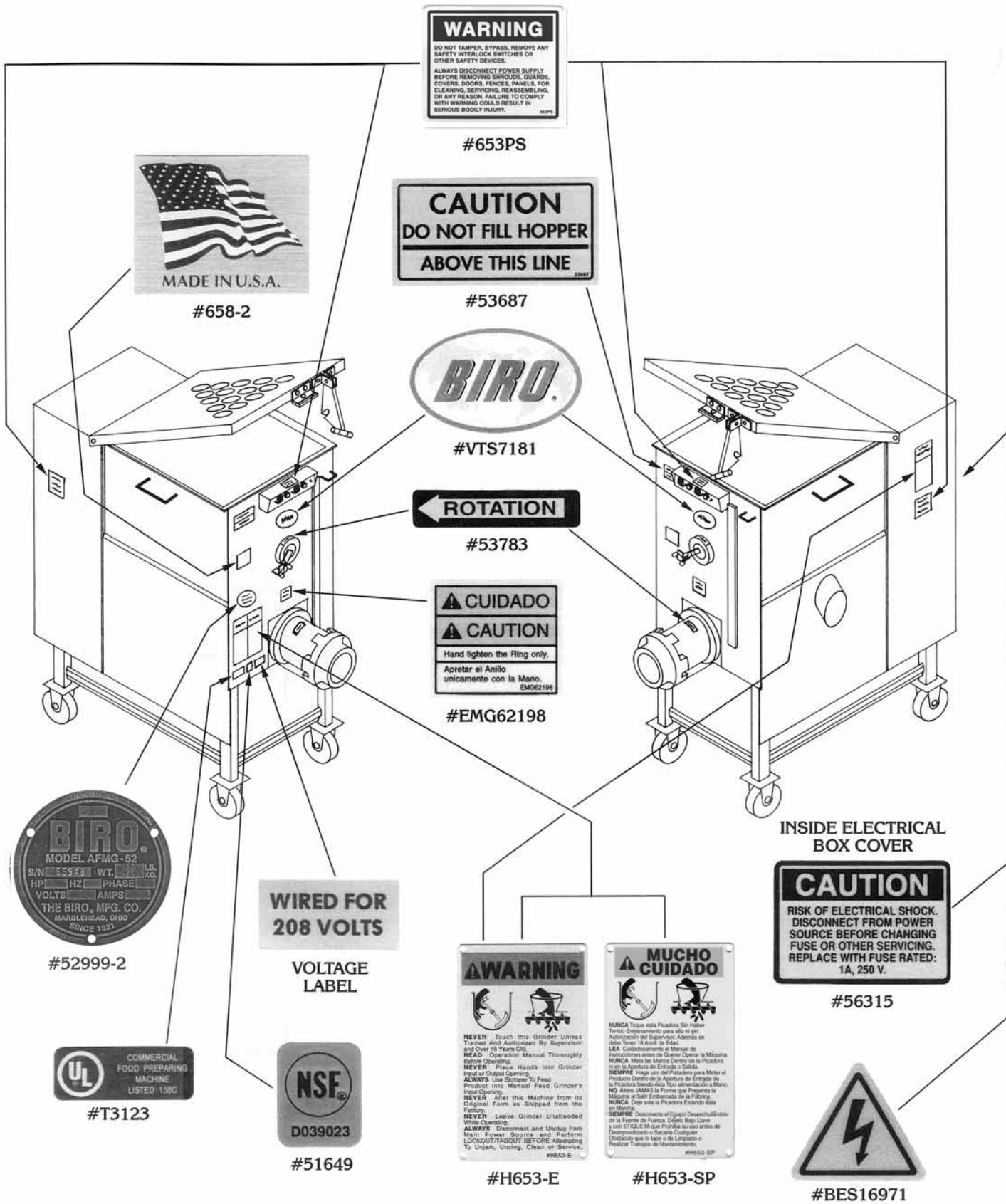

WARNING
DO NOT TAMPER, BYPASS, REMOVE ANY SAFETY INTERLOCK SWITCHES OR OTHER SAFETY DEVICES.
ALWAYS DISCONNECT POWER SUPPLY BEFORE REMOVING SHROUDES, GUARDS, COVERS, DOORS, FENCES, PANELS, FOR CLEANING, SERVICING, REASSEMBLING, OR ANY REASON. FAILURE TO COMPLY WITH WARNING COULD RESULT IN SERIOUS BODILY INJURY.

#653PS

CAUTION
DO NOT FILL HOPPER
ABOVE THIS LINE

#53687



#658-2



#VTS7181

ROTATION

#53783

CUIDADO
CAUTION
Hand tighten the Ring only.
Apretar el Anillo únicamente con la Mano.

#EMG62198



#52999-2

WIRED FOR 208 VOLTS

VOLTAGE LABEL



#T3123



#51649

WARNING
NEVER Touch this Grinder Unless Trained And Authorized By Supervisor and Cover 18 Years Old.
READ Operation Manual Thoroughly Before Operating.
NEVER Place Hands Into Grinder-Feed or Output Chute.
ALWAYS Use Stopper To Feed Product Into Manual Feed Grinders Inoperating.
NEVER Alter this Machine from its Original Form as Shipped from the Factory.
NEVER Leave Grinders Unattended While Operating.
ALWAYS Disconnect and Unplug from Main Power Source and Perform LOCKOUT/TAGOUT BEFORE Attempting To Unjam, Unplug, Clean or Service.

#H653-E

MUCHO CUIDADO
NUNCA Toque esta Picadora Sin Haber Tenido Entrenamiento para ello o sin Autorización del Supervisor. Además se debe Tener 18 Años de Edad.
LEA Cuidadosamente el Manual de Instrucciones antes de Operar la Máquina.
NUNCA Meta las Manos Dentro de la Picadora ni en la Abertura de Entrada o Salida.
SIEMPRE Haga uso del Pístaton para Meter el Producto Dentro de la Abertura de Entradas de la Picadora (Sólo en los Grinders Manuales).
NUNCA Altere JAMÁS la Forma que Presenta la Máquina al Salir de la Fábrica.
NUNCA Deje esta Picadora Estando Esta en Marcha.
SIEMPRE Desconecte el Equipo Desenchufándolo de la Fuente de Fuerza. Cierre Bien el Interruptor y con ETIQUETA que Prohíba su uso antes de Desconectarlo o Sacarlo Cuidadosamente. Verifique que lo hace o de Limpieza y Realice Trabajos de Mantenimiento.

#H653-SP

INSIDE ELECTRICAL BOX COVER

CAUTION
RISK OF ELECTRICAL SHOCK. DISCONNECT FROM POWER SOURCE BEFORE CHANGING FUSE OR OTHER SERVICING. REPLACE WITH FUSE RATED: 1A, 250 V.

#56315



#BES16971

— NOTES —

LIMITED WARRANTY

WARRANTY: The Biro Manufacturing Company warrants that the BIRO AFMG-52 Mixer Grinder/Chopper will be free from defects in material and workmanship under normal use and with recommended service. BIRO will replace defective parts, which are covered by this limited warranty, provided that the defective parts are authorized for return, shipping charges prepaid, to a designated factory for inspection and/or testing.

DURATION OF WARRANTY: The warranty period for all parts covered by this limited warranty is one (1) year from date of inspection/demonstration as advised on the returned Warranty registration card, or eighteen (18) months from original factory shipping date, whichever date occurs first, except as noted below.

PARTS NOT COVERED BY WARRANTY: The following are **not** covered by this limited warranty: wearable parts in the grinding system such as bowl, ring, worm, drive shaft, and knife drive pin. This limited warranty does not apply to machines sold as used, rebuilt, modified, or altered from the original construction in which the machine was shipped from the factory. Water contaminated electrical systems are not covered under this limited warranty. BIRO is not responsible for electrical connection of equipment, adjustments to the switch controls or any other electrical requirements, which must be performed only by a certified electrician. BIRO is not responsible for service charges or labor required to replace any part covered by this limited warranty or for any damages resulting from misuse, abuse, lack of proper or recommended service.

EXCLUSION OF WARRANTIES AND LIMITATION OF REMEDIES: BIRO gives no warranties other than those expressly stated in this limited warranty. THE IMPLIED WARRANTY OF MERCHANTABILITY, THE IMPLIED WARRANTY OF FITNESS FOR PROCESSING OF FOOD PRODUCTS, AND ALL OTHER IMPLIED WARRANTIES ARE SPECIFICALLY EXCLUDED. BIRO IS NOT LIABLE FOR CONSEQUENTIAL OR INCIDENTAL DAMAGES, EXPENSES, OR LOSSES. THE REMEDIES PROVIDED IN THIS BIRO LIMITED WARRANTY ARE PURCHASER'S SOLE AND EXCLUSIVE REMEDIES AGAINST BIRO.

REGISTRATION CARDS: You must sign, date and complete warranty registration card supplied with each machine. The warranty card must be returned to The Biro Manufacturing Company for proper registration. If no warranty card is returned to BIRO, the warranty period will begin from the date the machine was originally shipped from the factory.

HOW TO GET SERVICE:

1. Contact the entity from whom you purchased the machine; or
2. Consult the yellow pages of the phone directory for the nearest authorized dealer; or
3. Contact BIRO Mfg. Company for the authorized service entity (250 plus worldwide) in your area.

THE BIRO MANUFACTURING COMPANY

1114 Main Street

Marblehead, Ohio

Ph. 419-798-4451

Fax 419-798-9106

E-mail: service@biro saw.com

Web: <http://www.birosaw.com>