



MODEL 346 GRINDER PARTS LIST

Applicable Starting with Serial Number 24856



Biro Designed

Biro Built

THE BIRO MANUFACTURING COMPANY

MARBLEHEAD, OHIO 43440-2099 U.S.A.

FAX (419) 798-9106

Phone (419) 798-4451

TABLE OF CONTENTS

	Page
NOTICE TO OWNERS AND OPERATORS	1
SAFETY TIPS	2
INSTALLATION	3
UNCRATING AND SET UP	3
MOTOR WIRING AND ELECTRICAL REQUIREMENTS	4
MOTOR SPECIFICATIONS	4
OPERATION	6
TO PROCESS PRODUCT	6
CLEANING	7
MAINTENANCE	8
GRINDING BOWL INSTALLATION	8
BEARING HOUSING LUBRICATION	9
ROLLER CHAIN AND DRIVE SPROCKET LUBRICATION	9
MAIN DRIVE CHAIN TENSION	9
PARTS DIAGRAMS	10 & 11
WARNING LABEL LOCATIONS ON MACHINE	10 & 11
OPTIONAL STAINLESS STEEL BOWL, ENTERPRISE & UNGER	12
WIRING DIAGRAMS	13
PARTS LIST / ORDERING	14
OPERATOR'S SIGNATURE PAGE	15
LIMITED WARRANTY	16

NOTICE TO OWNERS AND OPERATORS

BIRO's products are designed to process food products safely and efficiently. Unless the operator is properly trained and supervised, however, there is the possibility of a serious injury. It is the responsibility of the owner to assure that this machine is used properly and safely, strictly following the instructions contained in this Manual and any requirements of local law.

No one should use or service this machine without proper training and supervision. All operators should be thoroughly familiar with the procedures contained in this Manual. Even so BIRO cannot anticipate every circumstance or environment in which its products will be used. You, the owner and operator, must remain alert to the hazards posed by the function of this equipment – particularly the ROTATING GRINDING WORM, which can severely injure an inattentive operator amputating fingers and limbs. No one under eighteen (18) years of age should operate this equipment. If you are uncertain about a particular task, ask your supervisor.

This Manual contains a number of safe practices in the SAFETY TIP section. Additional warnings are placed throughout the Manual. Warnings related to your personal safety are indicated by:



OR



Warnings related to possible damage are indicated by:



BIRO also has provided warning labels on the equipment. If any warning label or Manual becomes misplaced, damaged, or illegible, please contact your nearest Distributor or BIRO directly for a replacement.

Remember, however, this Manual or the warning labels do not replace the need to be alert and to use your common sense when using this equipment.

This Manual applies to machines with serial number 24856 and higher.

– NOTE –

A copy of this manual is included with each Model 346 Grinder.

**The descriptions and illustrations contained in this manual are not binding.
The manufacturer reserves the right to introduce any modifications
without updating the manual.**

SAFETY TIPS



ROTATING GRINDING WORM TO AVOID SERIOUS PERSONAL INJURY

***NEVER** Touch This Machine Without Training and Authorization By Your Supervisor.*

***ALWAYS** Read Operation and Service Manual **BEFORE** Operating, Cleaning or Servicing.*

***NEVER** Place Hands Into Machine Input or Output Openings.*

***NEVER** Open Machine During Operation.*

***ONLY** Use a Qualified Electrician to Install According to Local Building Codes: Machine **MUST** Be Properly Grounded.*

***ALWAYS** Connect to **Proper** Voltage & Phase.*

***ONLY** Install on Level, Non-Skid Surface in a Clean, Well-Lighted Work Area Away From Children and Visitors.*

***NEVER** Use This Machine For Non-Food Products.*

***NEVER** Operate Machine With Tray And/Or Tray Guard Removed or Magnetic Safety Switch By-Passed.*

***ALWAYS** Turn Off, Unplug From Power Source and Perform Lockout/Tagout Procedure to This Machine **BEFORE** Attempting to Unjam or Unclog, Cleaning or Servicing.*

***NEVER** Leave Machine Unattended While Operating.*

***NEVER** Alter This Machine From its Original Form as Shipped From Factory. **DO NOT** Operate Machine With Parts Missing.*

***PROMPTLY REPLACE** Any Worn or Illegible Warning Labels.*

***USE ONLY BIRO** Parts and Accessories Properly Installed.*

INSTALLATION



TO AVOID SERIOUS PERSONAL INJURY PROPERLY INSTALL EQUIPMENT IN ADEQUATE WORK AREA

ALWAYS Use Qualified Technician and Electrician for Installation.

*ALWAYS Connect to **Proper** Voltage & Phase.*

ALWAYS Install Equipment in Work Area with Adequate Light and Space Away From Children and Visitors.

ONLY Operate on a Solid, Level, Non-Skid Surface.

NEVER Bypass, Alter, or Modify This Equipment in Any Way From Its Original Condition.

NEVER Operate With Tray And/Or Tray Guard Removed or Magnetic Safety Switch By-Passed.

NEVER Operate Without all Warning Labels Attached and Owner/Operator Manual Available to the Operator.

UNCRATING AND SET UP

1. Read this Manual thoroughly before installation and operation. **Do not** proceed with installation and operation if you have any questions or do not understand anything in this Manual. Contact your local Distributor, or BIRO **first**.
2. Install machine on a level, solid, non-skid surface in a well-lighted work area away from children and visitors.



ALWAYS LEVEL MACHINE BEFORE USE

3. After installing machine in operating area, it is imperative that the four adjusting legs be adjusted to level the machine and also eliminate rocking.
4. This machine is complete **except** for a knife and plate. There is a bowl shipping plug (stamped steel) placed in the output end of the grinding bowl to retain the grinding worm during shipment. **REMOVE THE BOWL SHIPPING PLUG AND THE GRINDING WORM.**



5. After checking and making sure the power supply is correct, plug in your machine. **NEVER OPERATE MACHINE WITHOUT TRAY AND GUARD INSTALLED.** (Machine will not run with tray removed.)

6. Machine must be properly grounded. Use qualified electrician to install according to building codes.

MOTOR WIRING AND ELECTRICAL REQUIREMENTS

- (A) Interchange of current is made in motor outlet box. Leads are properly marked. Changing instructions are on the motor plate or motor outlet box.
- (B) All grinders are wired 220 volts unless otherwise specified. Be sure motor specifications (voltage, cycle, phase) match power supply line. Be sure line voltage is up to specification.
- (C) Electrical connections to be in accordance with safety codes and National Electrical Code.
- (D) Rated voltage of the unit shall be identical with full supply voltage.
- (E) Voltage drop on the supply line shall not exceed 10% of full supply voltage.
- (F) The feederline conductor size in the raceway from the branch circuit to the unit must be correct to assure adequate voltage under heavy starting and short overload conditions.
- (G) The feederline conductor shall only be used for the supply of one unit of the relevant horsepower. For connections of more than one unit on the same feederline, a local electrician will have to be consulted to determine the proper conductor size.
- (H) The size of the electrical wiring required from the power source to the grinder is a **MINIMUM OF No. 10 WIRE.**
- (I) The BIRO Manufacturing Company is not responsible for permanent wiring, connection or installation.



NOTE TO OWNER AND ELECTRICIAN: IF THIS MACHINE IS NOT CORD AND PLUG CONNECTED TO THE ELECTRICAL SUPPLY SOURCE, THEN IT SHOULD BE EQUIPPED WITH, OR CONNECTED TO, A LOCKABLE, MANUALLY-OPERATED DISCONNECT SWITCH (OSHA 1010.147).

MOTOR SPECIFICATIONS

HP	KW	VOLTS	HZ	PH	AMPS
3	2.2	208/220	60	3	14.0
3	2.2	440	60	3	7.0
3	2.2	550	60	3	6.8
3	2.2	230	60	1	16.0

7. A toggle handle that activates the internal on/off switch is located on the side of the machine. The interlock safety switch is mounted to the top of the internal switch and will break contact with the magnetic starter should the tray be removed.



8. Turn the toggle handle to the "ON" position. CHECK THE ROTATION OF THE WORM DRIVE SHAFT; ROTATION MUST BE COUNTER-CLOCKWISE as indicated by the rotation decal affixed to the grinding bowl. ROTATION MUST ONLY BE CHECKED WITH THE GRINDING WORM REMOVED, otherwise serious irreparable damage may occur to grinding components.
9. If machine runs clockwise (backwards), it must be rewired to correct rotation, otherwise serious irreparable damage may occur to grinding components.
10. Insert worm assembly into grinding bowl, place knife (sharp edges out) onto the square end of the worm assembly. The breaker plate slides over the worm knife drive pin, and is held from rotating by pins in the grinding bowl. Install the retaining ring.



ONLY HAND TIGHTEN RETAINING RING

For best results, use knife and plate as a set. Do not operate machine for any period of time without product in the grinding bowl. This will cause heating and dulling of the knife and plate.

11. Check placement of all warning labels and Manual. Machine is now ready for trained operators to process product.
12. Use meat deflector attached to tray to eliminate meat splatter.
13. Contact your local Distributor or BIRO directly if you have any questions or problems with the installation or operation of this machine.



OPERATION

ROTATING GRINDING WORM – TO AVOID SERIOUS PERSONAL INJURY

ONLY Properly Trained Personnel Should Use This Equipment.

NEVER Place Hands Into Machine Input or Output Openings.

NEVER Open Machine During Operation.

DO NOT Wear Gloves While Operating.

DO NOT Tamper With, Bypass, Alter, or Modify This Equipment in Any Way From Its Original Condition.

NEVER Operate Machine With Tray And/Or Tray Guard Removed or Magnetic Safety Switch By-Passed.

ALWAYS Turn Off, Unplug From Power Source and Perform Lockout/Tagout Procedure to This Machine Before Unjamming, Unclogging, Cleaning or Servicing.

NEVER Leave Unattended While Operating.

NEVER Operate Without All Warning Labels Attached and Owner/Operator Manual Available to the Operator.

A. TO PROCESS PRODUCT

1. Before starting grinder, have meat stomper within easy reach and container for receiving ground product at output end of grinding bowl.
2. Turn toggle handle to “ON” position. Look down grinder bowl and make certain grinding worm is turning in the proper direction (counter-clockwise).
3. Carefully push unground product to top opening of grinding bowl and let drop onto grinding worm. Product will then be ground out.



DO NOT REACH DOWN BOWL OPENING

4. Use meat stomper to assist any product that should “bridge up” in grinding bowl opening.
5. When finished grinding turn toggle handle to “OFF” position and unplug grinder from power source and perform lockout/tagout procedures.

DO's

- Always keep knife & plate as matched set.
- Always keep the knife & plate sharp.
- Always check for levelness by laying the knife on the plate before inserting in machine.
- Always install the knife & plate in correct sequence, knife 1st, then plate.
- Always keep knives & plates lubricated in storage and when starting up machine.
- Always use coolant when sharpening plates.
- Always inspect the plates making sure all holes are clear – that there are no cracks.

DON'Ts

- Never, never mix different knives to different plates.
- Never, never over tighten the bowl retaining ring on the machine.
- Never, never run the grinder/mincer without product. Product is a natural lubricant. Heat can build up so fast that cold product could crack the plate.
- Never, never hit the plate against anything to clean the holes.
- Never, never throw the knives & plates.

CLEANING



ROTATING GRINDING WORM TO AVOID PERSONAL INJURY

ALWAYS Turn Off, Unplug From Power Source and Perform Lockout/Tagout Procedure to This Machine **BEFORE** Cleaning or Servicing.

ONLY Use Recommended Cleaning Equipment, Materials and Procedures.

NEVER Spray Water or Other Liquid Substances Directly at Motor, Power Switch or any Other Electrical Components.

ALWAYS Thoroughly Clean Equipment at Least Daily.

CLEANING THE BIRO MODEL 346 GRINDER

1. Disconnect grinder from power source and perform lockout/tagout procedures.
2. Remove grinding bowl end ring, breaker plate, knife and grinding worm.



DO NOT POWER SPRAY DIRECTLY AT ELECTRICAL COMPONENTS

3. Machine is now ready to be cleaned using warm soapy water and rinsed with clean water. Machine may be cleaned by power spray washing, taking care to not spray directly at any electrical controls.
4. The grinding bowl can be removed for cleaning if desired. This is accomplished by unscrewing the bowl lock handle under the grinding bowl.
5. After machine has been cleaned and allowed to air dry, all exposed metal surfaces should be coated with a good food grade light oil or grease.

CLEANING THE BOWL – RING AND WORM CARE OF TIN COATED PRODUCTS (DO'S AND DON'TS)

1. Do not use abrasive cleaning materials, such as brillo pads or metal scrapers. Tin is a soft metal and should be cleaned with a soft cloth and dried.
2. Do not use a cleaning agent containing a high percentage of free alkali or acid.
3. Do not use a detergent containing a high percentage of tri-sodium phosphate or meta-silicate. Tin is reactive to both.
4. Rinse well and dry thoroughly after washing to remove agents that may be reactive to tin.
5. If sterilizing agent containing chlorine is used, the tinned surface must be thoroughly rinsed. Chlorine is corrosive to tin.
6. Dry thoroughly after rinsing and store in a dry environment.
7. If water is exceptionally hard, drying will be necessary to prevent spotting.

MAINTENANCE



ROTATING GRINDING WORM TO AVOID SERIOUS PERSONAL INJURY

ALWAYS Turn Off, Unplug From Power Source and Perform Lockout/Tagout Procedure to This Machine **BEFORE** Servicing.

NEVER Touch This Machine Without Training and Authorization By Your Supervisor.

NEVER Place Hands Into Machine Input or Output Openings.

NEVER Bypass, Alter, or Modify This Equipment in Any Way From Its Original Condition.

PROMPTLY REPLACE Any Worn or Illegible Labels.

USE ONLY GENUINE BIRO Parts and Accessories Properly Installed.

A. GRINDING BOWL INSTALLATION

1. Mount the grinding bowl rear hub in the bearing box. Be sure grinding bowl is fully seated. Tighten bowl lock handle. Hand tighten only.
2. Place the grinding worm in the grinding bowl and fully seat rear drive tang into worm drive shaft.
3. Install knife, breaker plate and end retaining ring.



ONLY HAND TIGHTEN RETAINING RING

4. When the bowl assembly is mounted and tight, there should be approximately $\frac{1}{8}$ " gap between the back inside wall of the bowl and the back of the worm (SEE FIGURE 1). The bowl ring wrench which is provided with each grinder is used only for **REMOVAL** of the end retaining ring for cleaning purposes or for changing knife and breaker plate.

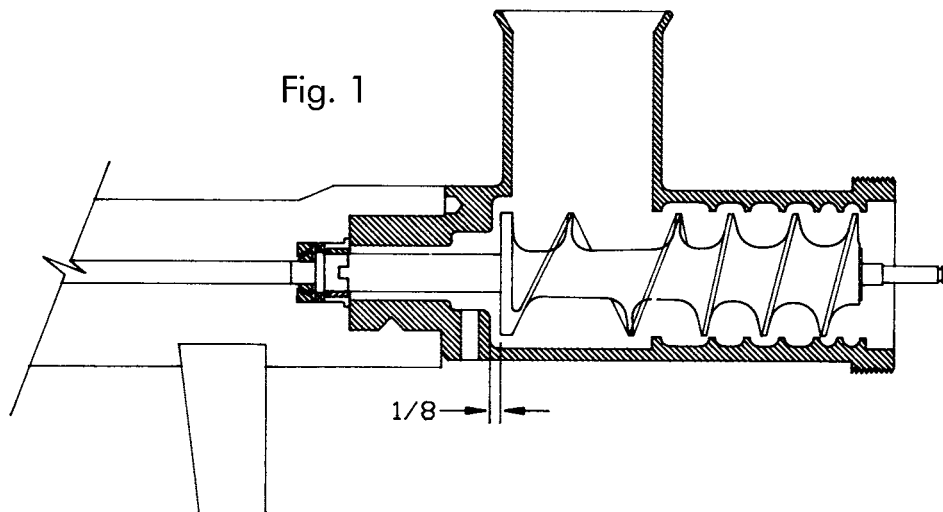

B. BEARING HOUSING LUBRICATION

1. Unplug grinder from power source and perform lockout/tagout procedures.
2. Unlatch tray, lift front slightly and slide toward back of machine. Lift tray from machine and set aside.
3. Unbolt case top cover and remove.
4. Check and relubricate with good grade of lithium bearing grease semi-annually.
5. Reinstall case top cover and bolt on tightly. Reinstall tray and latch securely.

C. ROLLER CHAIN AND DRIVE SPROCKET LUBRICATION

Chains should be protected against dirt and moisture. Chain life will vary appreciably depending upon lubrication. The better the lubrication, the longer the chain life.

Lubrication effectiveness will vary with the amount of lubrication and frequency of application. Ideally, a lubricant film should always be present between the working parts. Manually lubricate the chain after the 1st 6 weeks then every 6 months thereafter.

Lubricating just the outside of the chain does little good. Apply lubrication on the inside of the chain span so that it will work through the moving parts and joints by centrifugal force as the chain rotates and reach the area where one surface "scrubs" another.

Recommended types of chain lubricant are those with Molybdenum Disulphide or Graphite added. Also bonded lubricants such as Dow Corning's Molykote 321R or equivalent are excellent for open chains. The lubricant should be of a viscosity whereby it will "flow" somewhat and penetrate the internal working surfaces. Thick stiff greases are of little value because they cannot work into moving parts of the chain.

Symptoms of inadequate lubrication:

1. Excessive noise
2. Chain becomes stiff.
3. Chain runs hot.
4. Broken pins, bushings or rollers.
5. Excessive chain elongation — caused by wear on the pin outside diameter and bushing inside diameter. Once a chain is elongated or worn past acceptable limits, jumping of sprocket teeth and/or improper chain/sprocket mesh will occur.

LUBRICATING CHAIN AND SPROCKETS

1. Unplug grinder from power source and perform lockout/tagout procedures.
2. Unlatch tray, lift front slightly and slide toward back of machine. Lift tray from machine and set aside.
3. Unbolt case top cover and remove.
4. Spray or brush lubricant on inside of chain, slowly and carefully turning large sprocket by hand.
5. Reinstall case top cover and bolt on tightly. Reinstall tray and latch securely.

C. MAIN DRIVE CHAIN TENSION

1. Unplug grinder from power source and perform lockout/tagout procedures.
2. Remove feed tray.
3. Loosen motor mounting bolts.
4. Remove shims from under the motor. Important to remove same shims from back of motor as from the front for proper sprocket alignment.
5. Total chain flex should be $\frac{1}{8}$ " to $\frac{3}{8}$ " for proper chain tension. Do not over tension as this can cause excessive wear or premature failure of motor and bearing box bearings.
6. Retighten all motor mounting bolts.
7. Reinstall feed tray.

IMPORTANT:
PLEASE SPECIFY SERIAL NUMBER WHEN
ORDERING REPLACEMENT PARTS

- NOTE -

WARNING LABEL
LOCATIONS ON MACHINE

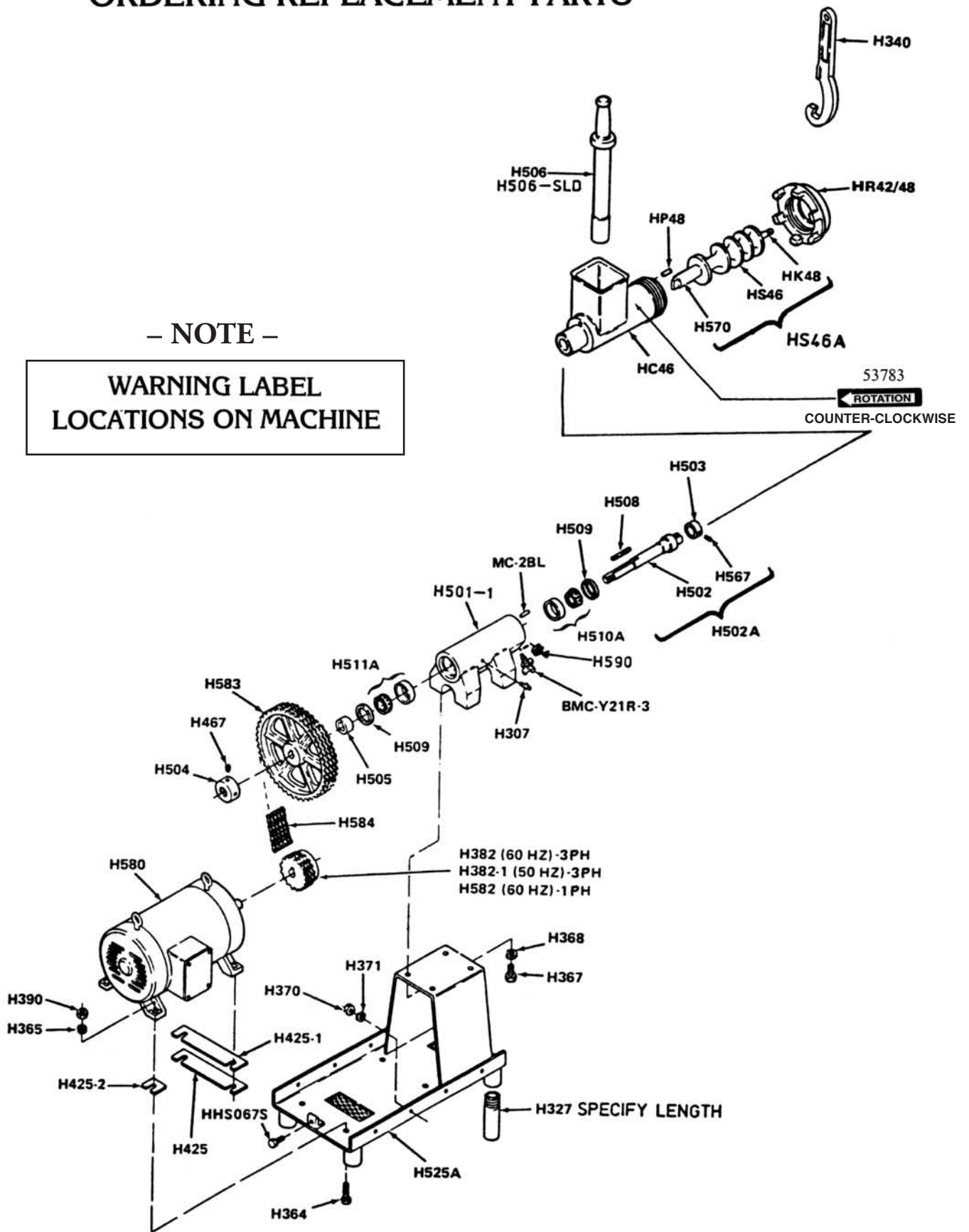

UNGER SYSTEM - 114mm

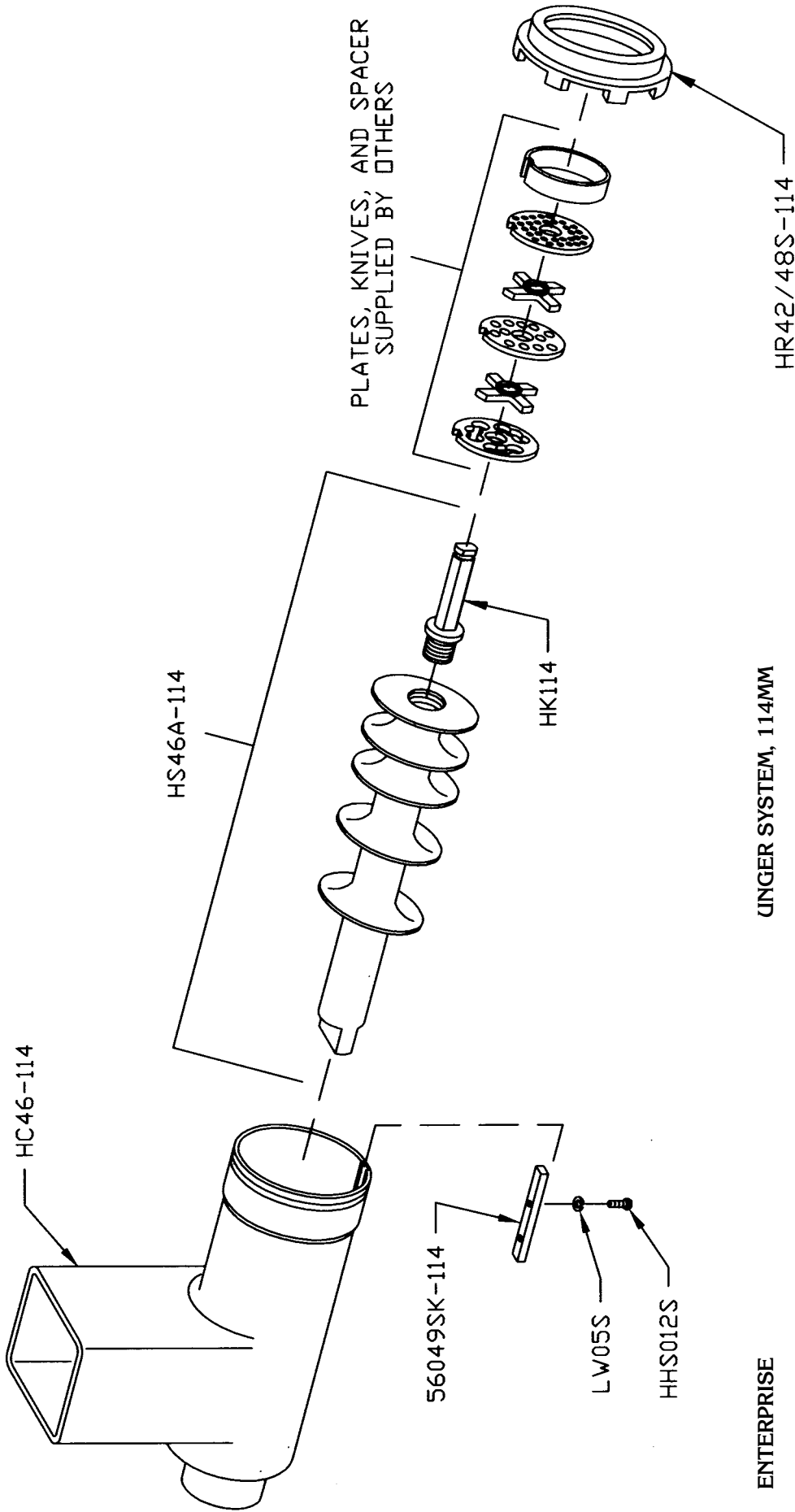

UNGER SYSTEM, 114MM

PART NO.	DESCRIPTION
HC46-114	Bowl, Unger 114MM, SS
HHS012S	Hex head screw, 10-32 x 1/2, SS
HK114	Knife drive pin, 114MM
HR42/48S-114	End ring, Unger 114MM, SS
HS46A-114	Worm assembly, Unger 114MM, SS
LW05S	Lock washer, # 10, SS
56049SK-114	Key, Unger 114MM, SS

ENTERPRISE

PART NO.	DESCRIPTION
HC46S	Bowl, SS
HR42/48S	End ring, SS
HS46AS	Worm assembly, SS

3 PHASE SWITCH WIRING & COMPONENTS

WIRING DIAGRAM FOR HEAVY HORSEPOWER
MANUAL FEED GRINDERS EQUIPPED WITH
AEG OR STROMBERG STARTERS

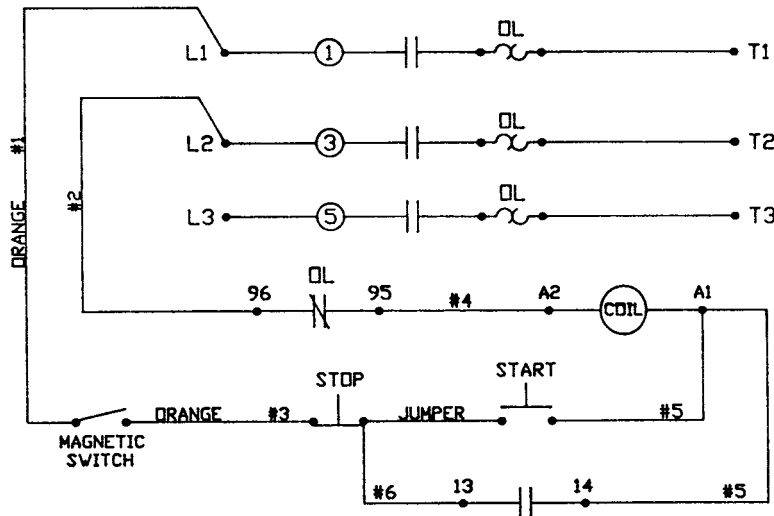

WIRING DIAGRAM FOR MODEL 346 HEAVY HORSEPOWER
MANUAL FEED GRINDER — 230 VOLT, 1 PHASE — EQUIPPED
WITH 3HP BALDOR CAPACITOR START MOTOR

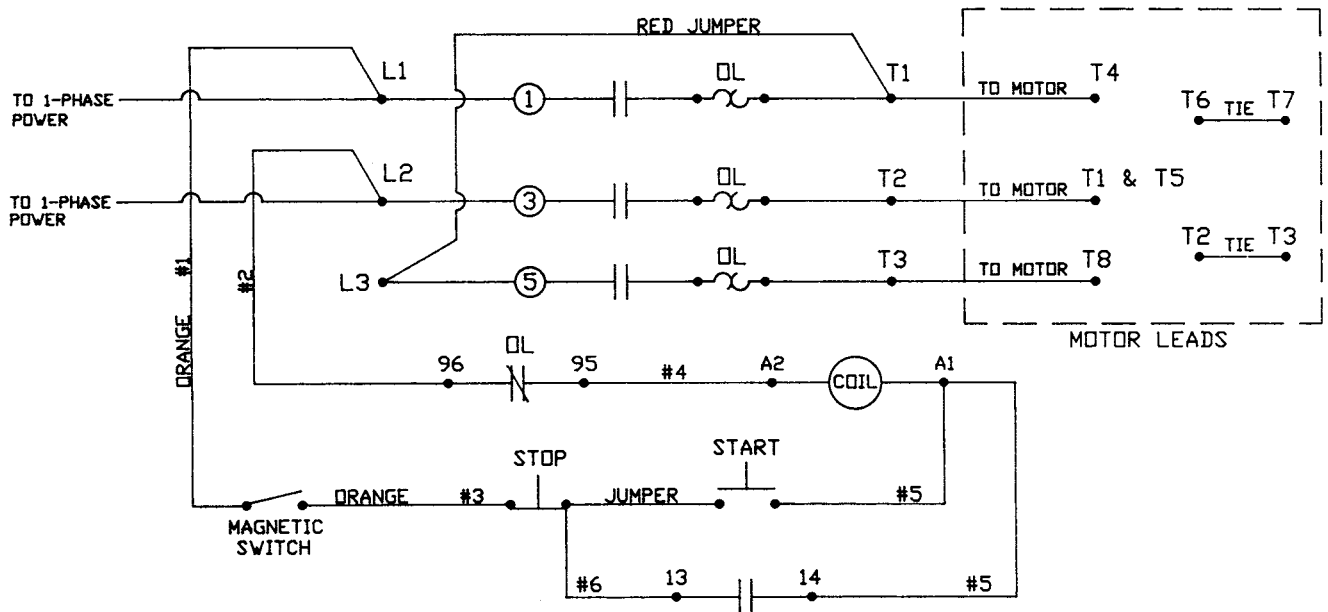

SWITCHES & SWITCH COMPONENTS

H281AE-31	Overload B27S-N 208/220V-3PH	H481AE-52	Overload B27S-L 380/440/550V
H281AE-32	Overload B27S-O 230V-1PH	H482-1	Green push button
H442	Magnet safety switch, up to 240V	H482-2	Red push button
H442-1	Magnet safety switch, above 240V	H578AE-10A	Switch assembly BAEG/3X-C17 208/220V-3PH
H478AE-ENCL-PB	Enclosure w/pushbutton holes	H578AE-11A	Switch assembly BAEG/3X-D8 308/415V
H479AE-220	Contactors SP27.10-CO 208/220/230V	H578AE-12A	Switch assembly BAEG/3X-E8 440V
H479AE-380	Contactors SP27.10-DO 380/415V	H578AE-13A	Switch assembly BAEG/3X-F8 550V
H479AE-440	Contactors SP27.10-EO 440V	H578AE-14A	Switch assembly BAEG/3XS-C23 230V-1PH
H479AE-550	Contactors SP27.10-FO 550V		

IMPORTANT: Must have Model and Serial Number when ordering Parts**PARTS LIST — MODEL 346 GRINDER**

Item No.	Description	Item No.	Description
14572	Ring wrench holder	H503	Tang collar 1 3/4 rd x 1" long
16163A	Tray hold down clip	H504	Shaft nut 2 3/8 rd x 1" long
42MC-2R1	Insert heli-coil, SS	H505	Shaft spacer, 1 3/4 rd x 1 1/4" long
42MC-441	Warning label "Do not remove guard"	H506	Stomper 11 1/4 long
42MCY64	Magnetic safety interlock switch up to 240V	H506-SLD	Solid stomper, "USDA Approved Polyethylene"
42MC-Y71SOUI	Hold down latch for removable tray	H508	Main shaft key 1/4 x 4 3/4 long
42MC-Y72	Retaining nut, 1/4-20 U-Type	H509	Seals — front & rear bearing
53783	Decal *Rotation	H512	Magnet housing
56049SK-114	Key, Unger system 114mm 1/4 x 9mm	H512-1	Magnet, #24856 on
CB60S	Carriage bolt, 1/4-20 x 1/2, SS	H513	Tray attachment bracket, .093 x 16"
FW06S	Flat washer, 1/4, SS	H517-1	Switch rod, 3/4rd x 16 3/4" long
FW10S	Flat washer, 5/16, SS	H539A	Spurt guard for SS tray 3/8
H307	Bearing box grease fitting 1/8	H567	Brass tip set screw, 3/8-16 x 3/8
H318-1	Switch cam, nylon 3/4 rd x 2 long	H570	Worm drive shaft
H319	Switch handle	H573	Round Phillip screw 6-32 x 3/8 self tap, box/case
H322	Conn. box cover, bell	H580	Motor, 3hp, 220/440V, 50/60-3
H323	Reducing washer RW75-50	H580-4	Motor, 3hp, 208/230-60-1
H323-1	Reducer RB75-50	H582	Motor pinion, 16 tooth x 1" bore
H324	Base feet 1 1/2 black pipe coupling	H583	Sprocket — 95 tooth by 1 1/8" bore
H327-11	Aluminum legs 1 1/2 x 11" long — std.	H584	Roller chain, 35-4, 122 pitches
H327-13	Aluminum legs 1 1/2 x 13" long — opt.	H586-4	Case top cover
H327-18	Aluminum legs 1 1/2 x 18" long — opt.	H589	5/16-18 x 3 1/2 SS carriage bolt, (4) reqd.
H327-19	Aluminum legs 1 1/2 x 19" long — opt.	H590	Heli-coil 9/16-12UNC x 1 1/8, #25641 on
H327-20	Aluminum legs 1 1/2 x 20" long — opt.	H591	Switch rod busing, 2 reqd.
H327-22	Aluminum legs 1 1/2 x 22" long — opt.	H591-1	Switch rod bushing nut
H328	Switch rod collar	H592	Star lock washer
H340	Aluminum ring wrench	H653-E	Warning label, English
H346	Bell connection box	H653-SP	Warning label, Spanish
H364	Hex head cap screw 1/2-13 x 2 1/4 (motor mount)	HC46	Bowl
H365	Lock washer, 1/2" plated	HC46S	Bowl, SS
H367	Hex head cap screw 5/8-11 x 2, bearing box/frame	HC46-114	Bowl, SS, Unger system, 114mm
H368	Lock washer 3/8, bearing box/A-frame	HHS012S	Hex head screw, 10-32 x 1/2, SS
H370	Hex nut 5/16-18 x 1/2 motor mount	HHS035S	Hex head screw, 1/4-20 x 3/8, SS
H371	Lock washer 5/16" base/case	HHS055S	Hex head screw, 5/16-18 x 3/4, SS, base/case
H376	Round screw 8-32 x 3/8 switch/case	HHS067S	Hex head screw 3/8-16 x 3/4, SS
H377	Hex nut 8-32 switch/case	HHS0671S	Hex head screw 3/8-16 x 1/2, SS
H382	Motor pinion 19 tooth, by 1" bore	HK114	Knife drive pin, Unger, 114mm
H382-1	Motor pinion 22 tooth for 50 cy	HK48	Knife drive pin
H390	Hex nut, 1/2-13 x 3/4 mtr. att.	HN15S	Hex nut, 1/4-20
H405	Socket set screw, 5/16-18 x 3/8	HN20S	Hex nut, 5/16-18, SS heavy
H425	Motor shim, 1/8 x 2 x 11 Fanalic	HN25S	Hex nut, 3/8-16 x 1 1/16 x 2 3/64, SS, heavy
H425-1	Motor shim, 1/16 x 2 x 11 Fanalic	HP48	Bowl pin, 1/32-1 1/4
H425-2	Motor shim, 1/32 x 2 x 3 Fanalic	HR42/48	Ring
H430	On/off decal	HR42/48S	Ring, SS
H442-1	Magnetic safety interlock switch, 380V and up	HR42/48S-114	Ring, Unger, 114mm, SS
H462	Guard for toggle switch	LW10S	Lock washer, 1/4, SS light
H462-1	Switch guard ferrule, 2 reqd.	LW15S	Lock washer, 5/16, SS regular
H466	Spurt guard mounting angle, SS	LW20S	Lock washer, 3/8, SS regular
H476	Hex nut, 5/16-18, SS	MC-2BL	Bowl locator pin dowel
H500-203	Operating manual	MC-410P	Bowl installation label
H501-1	Bearing box, #25641 on	MC-410SP	Bowl installation label, Spanish
H502	Main drive shaft, 1 7/8 x 12 1/2 long	WN20S	Wing nut 3/8-16, SS

ASSEMBLIES LIST

Item No.	Description	Item No.	Description
B42MC-49SS	Tray guard assembly, SS, #24856 on	H525A	Base plate assembly
BMC-Y21R-3	Bowl lock handle & screw assembly, 5/16, #24856 on	H588-1A	Tray assembly, left hand, #24856 on
H501A	Bearing box assembly, #24856 to #25640	H588-2A	Tray assembly, right hand, #24856 on
H501-1A	Bearing box assembly, #25641 on	HC46A	Bowl assembly, complete, (bowl, ring & worm assembly)
H502A	Drive shaft assembly, w/tang collar	HS46A	Worm assembly
H510A	Front bearing assembly	HS46AS	Worm assembly, SS
H511A	Rear bearing assembly	HS46A-114	Worm assembly Unger system, 114mm

LIMITED WARRANTY

WARRANTY: The BIRO Manufacturing Company warrants that the BIRO Model 346 Grinder will be free from defects in material and workmanship under normal use and with recommended service. BIRO will replace defective parts, which are covered by this limited warranty, provided that the defective parts are authorized for return, shipping charges prepaid, to a designated factory for inspection and/or testing.

DURATION OF WARRANTY: The warranty period for all parts covered by this limited warranty is one (1) year from date of inspection/demonstration as advised on the returned Warranty registration card, or eighteen (18) months from original factory shipping date, whichever date occurs first, except as noted below.

PARTS NOT COVERED BY WARRANTY: The following are **not** covered by this limited warranty: wearable parts in the grinding system such as bowl, worm drive shaft, ring, worm, and knife drive pin. This limited warranty does not apply to machines sold as used, rebuilt, modified, or altered from the original construction in which the machine was shipped from the factory. Water contaminated electrical systems are not covered under this limited warranty. BIRO is not responsible for electrical connection of equipment, adjustments to switch components or any other electrical requirements, which must be performed only by a certified electrician. BIRO is not responsible for service charges or labor required to replace any part covered by this limited warranty or for any damages resulting from misuse, abuse, lack of proper or recommended service.

EXCLUSION OF WARRANTIES AND LIMITATION OF REMEDIES: BIRO gives no warranties other than those expressly stated in this limited warranty. THE IMPLIED WARRANTY OF MERCHANTABILITY, THE IMPLIED WARRANTY OF FITNESS FOR PROCESSING OF FOOD PRODUCTS, AND ALL OTHER IMPLIED WARRANTIES ARE SPECIFICALLY EXCLUDED. BIRO IS NOT LIABLE FOR CONSEQUENTIAL OR INCIDENTAL DAMAGES, EXPENSES, OR LOSSES. THE REMEDIES PROVIDED IN THIS BIRO LIMITED WARRANTY ARE PURCHASER'S SOLE AND EXCLUSIVE REMEDIES AGAINST BIRO.

REGISTRATION CARDS: You must sign, date and complete the warranty registration card supplied with each machine. The warranty card must be returned to The Biro Manufacturing Company for proper registration. If no warranty card is returned to BIRO, the warranty period will begin from the date the machine was originally shipped from the factory.

HOW TO GET SERVICE:

1. Contact the agency from whom you purchased the machine; or
2. Consult the yellow pages of the phone directory for the nearest authorized dealer; or
3. Contact Biro Mfg. Company for the nearest authorized service entity (250 plus worldwide) in your area.

THE BIRO MANUFACTURING COMPANY

1114 Main Street
Marblehead, Ohio 43440-2099
Ph. 419-798-4451
Fax 419-798-9106
E-mail: Service@biro.saw.com
Web: <http://www.birosaw.com>