



Known for Reliability Since 1921

The BIRO Models 1433 and 1433FH (Fixed Head) Meat Cutters are compact production saws that are perfect for today's scaled down meat room. The 3HP, totally enclosed motors and 3550 feet per minute blade speed (higher speed available at no charge) provide you with the power you need. BIRO's exclusive EZ-Flow meat carriage helps reduce operator fatigue and increase productivity. Both Model 1433's feature a watertight magnetic starter with thermal overload protection, removable lower wheel, and double V belt and pulley drive system. Both models also incorporate the superior design and engineering you've come to expect from BIRO, which means you'll get years of use, low maintenance, and lower overall cost of ownership.

1433 / 1433FH



*Md. 1433 standard configuration,
movable head structure, right to
left feed, stationary rear table.*



*Md. 1433FH (fixed head structure)
right to left feed, movable front
carriage, stationary rear table.*

SPECIFICATIONS

Model: 1433 Power Meat Cutter (movable head) 14" (356 mm) saw blade wheels.
1433FH Power Meat Cutter (fixed head) 14" (356 mm) saw blade wheels.

Motors:	HP	KW	TYPE	VOLTS	AMPS	CYCLE	PH	STATUS
	3	2.2	TE	208/220/440	6.4/6/3	60	3	STD
	3	2.2	TE	220/380/415	6/4/3	50	3	STD
	2	1.5	OP-HH	115/208/230	20/11/10	60	1	STD
	2	1.5	OP-HH	220	9	50	1	EC
	3	2.2	TE	200	6	60	3	EC
	2	1.5	TE	550	2.8	60	3	EC

TE = Totally Enclosed OP = Open HH = High Humidity STD = Standard EC = Extra Cost

Construction: Heavy Gauge stainless steel base, legs, head and door structure.

Standard Features: Two saw blades, operation and parts manual, safety wall poster, end cut safety pusher plate.

Switch: Watertight magnetic with thermal overload and under voltage protection.

Head and Door: Stainless steel, movable on Std. 1433 and fixed on 1433FH.

Base Structure: Stainless steel, removable head door on both.

Blade Standard: Hard tooth .022 inch (.5 mm) thick, three teeth per inch (8.5 mm between teeth), 5/8 inch (16 mm) wide, 108 inches (2743 mm) long (two supplied with each saw).

Blade Speed: 3600 feet (1097 m) per minute. Approx. 50/60 cycle.

Blade Back-up Guides: Upper and lower blade backup guide assemblies, removable with long life carbide backup inserts.

Blade Tension: 1433 - ratchet arm and cam against tension spring gauge
1433FH - factory preset spring, screw handle assembly.

Blade Wheels: 14" (355 mm) cast iron, chrome nickel plating, upper wheel assembly lifts out, lower wheel removable.

Bearings: Heavy duty tapered roller bearings used in upper wheel and lower bearing housings.

Catch Pan: Poly, extra deep (rounded corners), pan sealed off from other parts of base, accessible through base hinged door.

Cleaning Unit: Stainless steel body, long-life carbide guides, steel saw cleaners, removable as a unit for easy cleaning (assembly also adjustable as a unit).

Drive System: Non slip silent v-belt, tension adjustable.

Legs: Four stainless steel leg bolt levelers.

Meat Carriage: Stainless steel with 8 stainless steel bearings e-z flow.

Meat Gauge Plate: Stainless steel faced, adjustable from 1/16" (1.59 mm) to 6-1/2" (165 mm) locks in position, can be disengaged, entire assembly removable for cleaning.

Motor Compartment: Sealed off from meat contact areas, easily accessible through removable panel door.

Rear (Table) Platter: All stainless steel, held in place with two push pull hold down stainless steel rods.

Safety End Cut Pusher Plate: Standard, removable, pusher plate storage hanger provided.

Options (EC): Power cord and plug, front table extension, stainless steel single flange blade wheels, stationary front table, double flange cast blade wheels, split rear platter, longer meat gauge plates, meat gauge plate stabilizer.

Options (NC): 4200 feet (1280 m) per minute blade speed.

Certification: U.S.D.A., U.L., N.S.F.

Weight: 1433 Uncrated: 374 lbs. (169.6 kg) approximate.
 Crated: 478 lbs. (217 kg) approximate.
1433FH Uncrated: 385 lbs. (174.6 kg) approximate.
 Crated: 489 lbs. (222 kg) approximate.

Dimensions crated 1433: L=48" (121.9 cm), W=37" (93.9 Cm), H=38" (96.5 cm).
1433FH: L=38" (96.5 cm), W=50" (127 cm), H=77" (195.6 cm).

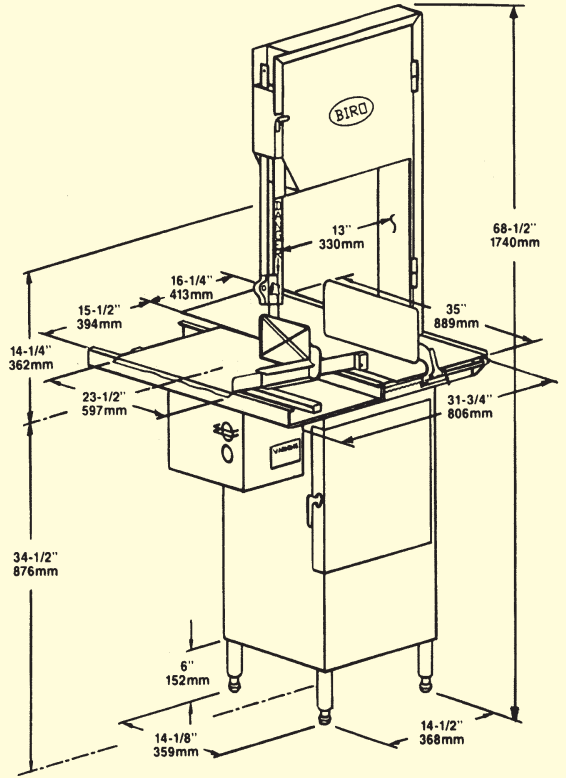

MD. 1433 MOVABLE HEAD, STD. CONFIGURATION

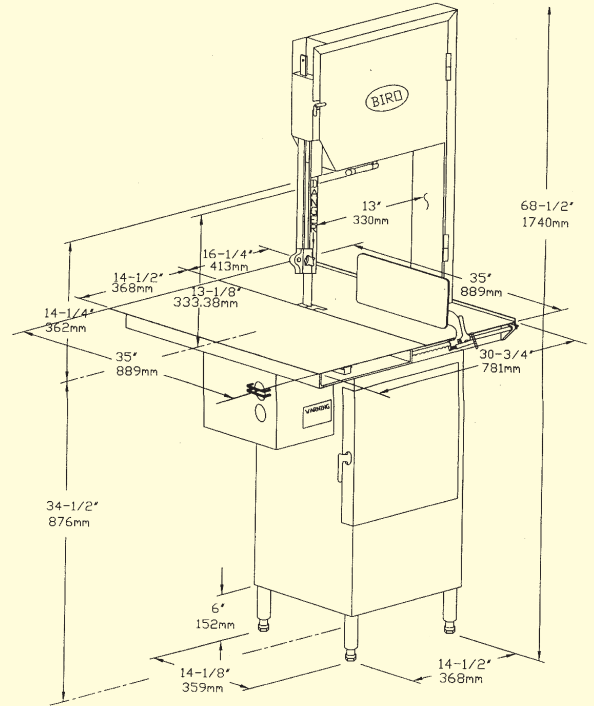

MD. 1433FH WITH STATIONARY FRONT AND REAR TABLES

THE BIRO MANUFACTURING COMPANY
1114 WEST MAIN STREET
MARBLEHEAD, OH 43440-2099 U.S.A.

Distributor:
Berkel Miami Inc.
3800 NW 125 St.
Opa Locka, FL 33054

Tel.# (305) 622-8899
www.berkelmiami.com

All specifications contained herein are subject to change without notification.

Service is available from over 260 locations worldwide